

# **SynoVent E5 Ventilator**

## **Operator's Manual**





© 2010-2014 Shenzhen Mindray Bio-Medical Electronics Co., Ltd. All rights Reserved.

For this Operator's Manual, the issue date is April, 2014.

---

# Intellectual Property Statement

SHENZHEN MINDRAY BIO-MEDICAL ELECTRONICS CO., LTD. (hereinafter called Mindray) owns the intellectual property rights to this Mindray product and this manual. This manual may refer to information protected by copyright or patents and does not convey any license under the patent rights or copyright of Mindray, or of others.

Mindray intends to maintain the contents of this manual as confidential information. Disclosure of the information in this manual in any manner whatsoever without the written permission of Mindray is strictly forbidden. Release, amendment, reproduction, distribution, rental, adaptation, translation or any other derivative work of this manual in any manner whatsoever without the written permission of Mindray is strictly forbidden.

**mindray**,  **MINDRAY** and SynoVent are the trademarks, registered or otherwise, of Mindray in China and other countries. All other trademarks that appear in this manual are used only for informational or editorial purposes. They are the property of their respective owners.

---

# Responsibility on the Manufacturer Party

Contents of this manual are subject to change without prior notice.

All information contained in this manual is believed to be correct. Mindray shall not be liable for errors contained herein or for incidental or consequential damages in connection with the furnishing, performance, or use of this manual.

Mindray is responsible for the effects on safety, reliability and performance of this product, only if:

- all installation operations, expansions, changes, modifications and repairs of this product are conducted by Mindray authorized personnel;
- the electrical installation of the relevant room complies with the applicable national and local requirements;and
- the product is used in accordance with the instructions for use.



## **WARNING**

- **It is important for the hospital or organization that employs this equipment to carry out a reasonable service/maintenance plan. Neglect of this may result in machine breakdown or personal injury.**
- 

## **NOTE**

- **This equipment must be operated by skilled/trained clinical professionals.**
-

---

# Warranty

THIS WARRANTY IS EXCLUSIVE AND IS IN LIEU OF ALL OTHER WARRANTIES, EXPRESSED OR IMPLIED, INCLUDING WARRANTIES OF MERCHANTABILITY OR FITNESS FOR ANY PARTICULAR PURPOSE.

## Exemptions

Mindray's obligation or liability under this warranty does not include any transportation or other charges or liability for direct, indirect or consequential damages or delay resulting from the improper use or application of the product or the use of parts or accessories not approved by Mindray or repairs by people other than Mindray authorized personnel.

This warranty shall not extend to:

- Malfunction or damage caused by improper use or man-made failure.
- Malfunction or damage caused by unstable or out-of-range power input.
- Malfunction or damage caused by force majeure such as fire and earthquake.
- Malfunction or damage caused by improper operation or repair by unqualified or unauthorized service people.
- Malfunction of the instrument or part whose serial number is not legible enough.
- Others not caused by instrument or part itself.

---

# Customer Service Department

Manufacturer: Shenzhen Mindray Bio-Medical Electronics Co., Ltd.  
Address: Mindray Building, Keji 12th Road South, High-tech industrial park, Nanshan, Shenzhen 518057, P.R. China  
Website: [www.mindray.com](http://www.mindray.com)  
E-mail Address: [service@mindray.com](mailto:service@mindray.com)  
Tel: +86 755 81888998  
Fax: +86 755 26582680

EC-Representative: Shanghai International Holding Corp. GmbH (Europe)  
Address: Eiffestraße 80, 20537 Hamburg, GERMANY  
Tel: 0049-40-2513175  
Fax: 0049-40-255726

---

# Preface

## Manual Purpose

This manual contains the instructions necessary to operate the product safely and in accordance with its function and intended use. Observance of this manual is a prerequisite for proper product performance and correct operation and ensures patient and operator safety.

This manual is based on the maximum configuration and therefore some contents may not apply to your product. If you have any question, please contact us.

This manual is an integral part of the product. It should always be kept close to the equipment so that it can be obtained conveniently when needed.

## Intended Audience

This manual is geared for clinical professionals who are expected to have a working knowledge of medical procedures, practices and terminology as required for monitoring of critically ill patients.

## Illustrations

All illustrations in this manual serve as examples only. They may not necessarily reflect the setup or data displayed on your ventilator.

## Conventions

- *Italic* text is used in this manual to quote the referenced chapters or sections.
- [ ] is used to enclose screen texts.
- → is used to indicate operational procedures.

## Password

A password is required to access different modes within the ventilator machine.

- User maintenance: 1234



# Table of Contents

<b>1 Safety</b> .....	<b>1-1</b>
1.1 Safety Information .....	1-1
1.1.1 Dangers .....	1-2
1.1.2 Warnings.....	1-2
1.1.3 Cautions .....	1-4
1.1.4 Notes .....	1-6
1.2 Equipment Symbols .....	1-7
<b>2 The Basics</b> .....	<b>2-1</b>
2.1 System Description .....	2-1
2.1.1 Intended Use.....	2-1
2.1.2 Contraindications .....	2-1
2.1.3 Components .....	2-1
2.2 Equipment Appearance .....	2-2
2.2.1 Front View.....	2-2
2.2.2 Rear View.....	2-4
2.2.3 Air Compressor .....	2-5
<b>3 Installations and Connections</b> .....	<b>3-1</b>
3.1 Install the Display .....	3-1
3.1.1 Install the Display onto the Ventilator.....	3-1
3.1.2 Install the Display onto the Pendant.....	3-2
3.2 Connect the Power Supply .....	3-4
3.2.1 Connect the System Power Supply .....	3-4
3.2.2 Connect the Main Unit Power Supply.....	3-5
3.2.3 Connect the Compressor Power Supply.....	3-6
3.3 Connect the Gas Supply .....	3-7
3.4 Install the Support Arm .....	3-8
3.5 Install the Water Traps.....	3-10
3.6 Install the Breathing Hoses .....	3-11
3.7 Install the Humidifier .....	3-12
3.7.1 Install the Humidifier onto the Ventilator.....	3-12
3.7.2 Install the Humidifier onto the Pendant .....	3-13
3.8 Install the Nebulizer .....	3-15
3.9 Install the CO2 Module.....	3-16
3.10 Install the O2 Sensor .....	3-17
<b>4 User Interface</b> .....	<b>4-1</b>
4.1 Display Controls .....	4-1
4.1.1 Display .....	4-2
4.1.2 Fixed Hard Keys .....	4-4
4.2 Waveforms Screen.....	4-6

---

4.3 Spirometry Loops Screen.....	4-7
4.4 Graphic Trend Screen.....	4-8
4.5 Tabular Trend Screen .....	4-10
4.6 Measured Values Screen.....	4-11
4.7 Freeze.....	4-12
<b>5 System Settings.....</b>	<b>5-1</b>
5.1 Change Display Settings .....	5-1
5.1.1 Waveforms .....	5-1
5.1.2 Spirometry Loops.....	5-1
5.1.3 Measured Values .....	5-1
5.1.4 Colors.....	5-2
5.2 Set Date and Time .....	5-3
5.3 Change Language.....	5-3
5.4 Adjust Screen Brightness .....	5-3
5.5 Adjust Key Volume .....	5-3
5.6 Set Unit .....	5-3
5.6.1 Set Weight Unit.....	5-3
5.6.2 Set Paw Unit.....	5-4
5.6.3 Set CO2 Unit.....	5-4
5.7 Turning on/off O2% Monitoring.....	5-4
5.8 Select Tinsp/I:E .....	5-4
5.9 Set TV/f Source.....	5-4
5.10 Set Sigh .....	5-4
5.11 Set IP Address .....	5-5
5.12 Manage Configurations.....	5-5
5.12.1 Restore the Latest Configuration Automatically .....	5-5
5.12.2 Set Power-on Default Configuration.....	5-5
5.12.3 Save as User Configuration.....	5-6
5.12.4 Load Configuration Manually.....	5-6
5.13 View System Information.....	5-6
5.13.1 Version Information.....	5-6
5.13.2 Configuration Information .....	5-6
5.13.3 System Check Results .....	5-6
5.13.4 Maintenance Information .....	5-6
5.14 Export.....	5-7
5.14.1 Export Screen.....	5-7
5.14.2 Export Data .....	5-7
<b>6 Start Ventilation.....</b>	<b>6-1</b>
6.1 Turn on the System .....	6-1
6.2 Preoperative Test.....	6-1
6.2.1 AC Power and Battery Power Source Switch Test.....	6-1
6.2.2 Pipeline Tests.....	6-1
6.3 Power on Self-test .....	6-2

---

---

6.4 System Check.....	6-2
6.5 Select Patient.....	6-3
6.6 Ventilation Type .....	6-4
6.6.1 Invasive Ventilation.....	6-4
6.6.2 NIV (non-invasive ventilation) .....	6-5
6.6.3 Set Ventilation Type .....	6-5
6.7 Ventilation Mode.....	6-6
6.7.1 Ventilation Mode and Parameter Setup .....	6-6
6.7.2 Apnea Ventilation .....	6-7
6.7.3 IntelliCycle.....	6-8
6.7.4 V-A/C .....	6-8
6.7.5 P-A/C .....	6-10
6.7.6 CPAP/PSV.....	6-11
6.7.7 V-SIMV and P-SIMV .....	6-13
6.7.8 PRVC.....	6-16
6.7.9 DuoLevel.....	6-18
6.7.10 APRV.....	6-19
6.8 Change Alarm Limits .....	6-20
6.9 Ventilate the Patient.....	6-20
6.10 Ventilation Parameters Monitoring .....	6-21
6.11 Enter Standby .....	6-23
6.12 Turn the System off.....	6-23
<b>7 CO2 Monitoring .....</b>	<b>7-1</b>
7.1 Introduction.....	7-1
7.2 Prepare to Measure CO2 .....	7-2
7.3 Make CO2 Settings .....	7-3
7.3.1 Set Working Mode.....	7-4
7.3.2 Set Pump Rate .....	7-4
7.3.3 Set Unit .....	7-4
7.3.4 Set Humidity Compensation .....	7-5
7.3.5 Restore Defaults .....	7-5
7.3.6 Set CO2 Waveform .....	7-5
7.4 Measurement Limitations.....	7-5
7.5 Troubleshooting .....	7-6
7.6 Zero the Sensor .....	7-6
7.7 Calibrate the Sensor .....	7-6
<b>8 Special Functions.....</b>	<b>8-1</b>
8.1 Manual Breath.....	8-1
8.2 Expiration Hold.....	8-1
8.3 Inspiration Hold .....	8-2
8.4 Nebulizer .....	8-2
8.5 O2 ↑ .....	8-3
8.6 Suction .....	8-3

---

---

8.7 P0.1 .....	8-4
8.8 NIF .....	8-4
8.9 PEEPi .....	8-5
8.10 P-V Tool .....	8-5
<b>9 Alarms .....</b>	<b>9-1</b>
9.1 Introduction .....	9-1
9.2 Alarm Categories .....	9-1
9.3 Alarm Levels .....	9-2
9.4 Alarm Indicators .....	9-2
9.4.1 Alarm Lamp .....	9-2
9.4.2 Audible Alarm Tones .....	9-3
9.4.3 Alarm Message .....	9-3
9.4.4 Flashing Alarm Numeric .....	9-3
9.4.5 Alarm Status Symbol .....	9-4
9.5 Set Alarm Volume .....	9-4
9.6 Set Alarm Limits .....	9-4
9.7 Set Apnea Time .....	9-5
9.8 Alarm Silence .....	9-5
9.8.1 How to Set Alarm Silence .....	9-5
9.8.2 How to Cancel Alarm Silence .....	9-5
9.9 Alarm Reset .....	9-6
9.10 Nurse Call .....	9-6
9.11 Alarm Test .....	9-7
9.11.1 Battery in Use Alarm .....	9-7
9.11.2 Battery Depletion Alarm .....	9-7
9.11.3 Paw Too High Alarm .....	9-8
9.11.4 TV Not Achieved Alarm .....	9-8
9.11.5 MV Too Low Alarm .....	9-8
9.11.6 O2 Supply Pressure Low Alarm .....	9-8
9.11.7 Air Supply Pressure Low Alarm .....	9-9
9.11.8 Airway Obstructed Alarm .....	9-9
9.11.9 FiO2 Too High Alarm .....	9-9
9.11.10 FiO2 Too Low Alarm .....	9-9
9.11.11 EtCO2 Too High Alarm .....	9-9
9.11.12 EtCO2 Too Low Alarm .....	9-10
9.12 Alarm Logbook .....	9-10
9.13 When an Alarm Occurs .....	9-11
<b>10 Cleaning and Disinfection .....</b>	<b>10-1</b>
10.1 Methods for Cleaning and Disinfection .....	10-2
10.2 Disassemble the Ventilator's Cleanable Parts .....	10-4
10.2.1 Expiration Valve Assembly .....	10-4
10.2.2 Expiration Valve Flow Sensor .....	10-5
10.2.3 Water Trap .....	10-6

---

---

10.2.4 Breathing Hoses .....	10-7
10.2.5 Nebulizer .....	10-8
10.2.6 Humidifier .....	10-9
10.2.7 O2 Sensor .....	10-12
<b>11 Maintenance.....</b>	<b>11-1</b>
11.1 Repair Policy .....	11-1
11.2 Maintenance Schedule.....	11-2
11.3 Pressure and Flow Zeroing.....	11-3
11.4 Flow Sensor Calibration.....	11-4
11.5 O2 Concentration Calibration .....	11-5
11.6 CO2 Module Calibration .....	11-6
11.7 Touch Screen Calibration .....	11-7
11.8 Battery Maintenance .....	11-7
11.8.1 Battery Use Guidance.....	11-8
11.8.2 Battery Performance Conditioning.....	11-9
11.8.3 Battery Performance Checking.....	11-9
11.8.4 Battery Recycling .....	11-10
11.9 Electrical Safety Inspection.....	11-10
11.9.1 Auxiliary Electrical Outlet Test.....	11-10
11.9.2 Electrical Safety Inspection Test .....	11-11
11.10 Water Build-up in the Flow Sensor .....	11-12
11.10.1 Prevent Water Build-up .....	11-12
11.10.2 Clear Water Build-up.....	11-12
<b>12 Accessories .....</b>	<b>12-1</b>
<b>A Theory of Operation.....</b>	<b>A-1</b>
A.1 Pneumatic System .....	A-1
A.2 Electrical System.....	A-6
<b>B Product Specifications.....</b>	<b>B-1</b>
B.1 Safety Specifications .....	B-1
B.2 Environmental Specifications.....	B-2
B.3 Power Requirements.....	B-2
B.4 Physical Specifications.....	B-3
B.5 Pneumatic System Specifications.....	B-4
B.6 Ventilator Specifications.....	B-5
B.7 Ventilator Accuracy .....	B-7
B.8 Alarms .....	B-9
B.9 Special Functions .....	B-10
B.10 CO <sub>2</sub> Module Specifications .....	B-11
B.11 Compressor Specifications .....	B-12
B.12 O <sub>2</sub> Sensor Specifications .....	B-12

---

---

<b>C EMC .....</b>	<b>C-1</b>
<b>D Alarm Messages .....</b>	<b>D-1</b>
D.1 Physiological Alarm Messages.....	D-1
D.2 Technical Alarm Messages .....	D-2
<b>E Factory Defaults .....</b>	<b>E-1</b>
E.1 CO2 Module .....	E-1
E.2 Alarm .....	E-1
E.3 Ventilation Mode .....	E-2
<b>F Symbols and Abbreviations.....</b>	<b>F-1</b>
F.1 Symbols.....	F-1
F.2 Abbreviations .....	F-3

# 1 Safety

---

---

## 1.1 Safety Information

---

---

### DANGER

---

- Indicates an imminent hazard that, if not avoided, will result in death or serious injury.
- 
- 

### WARNING

---

- Indicates a potential hazard or unsafe practice that, if not avoided, could result in death or serious injury.
- 
- 

### CAUTION

---

- Indicates a potential hazard or unsafe practice that, if not avoided, could result in minor personal injury or product/property damage.
- 
- 

### NOTE

---

- Provides application tips or other useful information to ensure that you get the most from your product.
- 
-

---

### 1.1.1 Dangers

There are no dangers that refer to the product in general. Specific “Danger” statements may be given in the respective sections of this manual.

### 1.1.2 Warnings

---

#### **WARNING**

---

- **The ventilator must only be operated and used by authorized medical personnel well trained in the use of this product. It must be operated strictly following the Operator’s Manual.**
  - **To avoid the risk of electric shock, this equipment must only be connected to supply mains with protective earth.**
  - **The equipment must be connected to a properly installed power outlet with protective earth contacts only. If the installation does not provide for a protective earth conductor, disconnect it from the power line.**
  - **Use AC power source before the batteries are depleted.**
  - **To avoid explosion hazard, do not use the equipment in the presence of flammable anesthetic agent, vapors or liquids.**
  - **Do not place the ventilator adjacent to any barrier, which can prevent cold air from flowing, resulting in equipment overheat.**
  - **Do not open the equipment housings. All servicing and future upgrades must be carried out by the personnel trained and authorized by us only.**
  - **Do not rely exclusively on the audible alarm system for patient monitoring. Adjustment of alarm volume to a low level may result in a hazard to the patient. Remember that alarm settings should be customized according to different patient situations and always keeping the patient under close surveillance is the most reliable way for safe patient monitoring.**
  - **The physiological parameters and alarm messages displayed on the screen of the equipment are for doctor’s reference only and cannot be directly used as the basis for clinical treatment.**
  - **Dispose of the package material, observing the applicable waste control regulations and keeping it out of children’s reach.**
  - **All staff should be aware that disassembling or cleaning some parts of the ventilator can cause risk of infection.**
  - **Maintenance mode should be used only when the equipment is not connected to a patient.**
-



---

---

 **WARNING**

---

- **Positive pressure breathing may be accompanied by some side effects such as barotrauma, hypoventilation, hyperventilation etc.**
  - **Using the ventilator in the vicinity of high-frequency electrosurgery units, defibrillators or short-wave therapy equipment may impair correct functioning of the ventilator and endanger the patient.**
  - **Do not use antistatic or conductive masks or breathing hoses. They can cause burns if they are used near high frequency electrosurgical equipment.**
  - **Do not use the ventilator in a hyperbaric chamber to avoid potential fire hazard due to an oxygen-enriched environment.**
  - **If the equipment internal monitoring system malfunctions, an alternative plan must be available to ensure adequate level of monitoring. The operator of the ventilator must be responsible for proper patient ventilation and safety under all circumstances.**
  - **As required by the relevant rules and regulations, oxygen concentration should be monitored when the equipment is used on the patient. If your ventilator is not configured with such monitoring function or this function is turned off, use a monitor which complies with the relevant international rules and regulations for oxygen concentration monitoring.**
  - **When auxiliary electrical outlets are configured, the voltage and current specifications of the devices connected to the electrical outlets must be within the permissible ranges for those of the electrical outlets. When the protection grounding is defective, connection of equipment to the auxiliary electrical outlet may increase the patient leakage current to values exceeding the allowable limits.**
  - **When the auxiliary electrical outlet does not work normally, check if the corresponding fuse is burned.**
  - **All analog or digital products connected to this system must be certified passing the specified IEC standards (such as IEC 60950 for data processing equipment and IEC 60601-1 for medical electrical equipment). All configurations shall comply with the valid version of IEC 60601-1-1. The personnel who are responsible for connecting the optional equipment to the I/O signal port shall be responsible for medical system configuration and system compliance with IEC 60601-1-1 as well.**
  - **Do not touch the patient when connecting the peripheral equipment via the I/O signal ports or replacing the oxygen cell to prevent patient leakage current from exceeding the requirements specified by the standard.**
  - **This product must be operated by doctors, respiration therapist or other specially trained and authorized personnel. Anyone unauthorized or untrained must not perform any operation on it.**
  - **This equipment is not suitable for use in an MRI environment.**
-

---

---

** WARNING**

---

- **When the ventilator input system fails or has faults, please contact us immediately for specified personnel to service the ventilator.**
  - **Use the humidifiers with a CE mark or recommended by us only.**
  - **The ventilator cannot use He and O2 mixed gas.**
  - **Do not move the ventilator before removing the support arm from it, in order to avoid the ventilator getting tilted during the movement.**
  - **Nebulization or humidification can increase the resistance of breathing system filters and that you need to monitor the filter frequently for increased resistance and blockage.**
  - **The ventilation accuracy can be affected by the gas added by use of a nebulizer.**
  - **The ventilator shall not be used with nitric oxide.**
  - **The ventilator shall not be used with helium or mixtures with Helium.**
  - **For non-invasive ventilation, the exhaled volume of the patient can differ from the measured exhaled volume due to leaks around the mask.**
  - **Check if the alarm limit settings are appropriate before taking measurement.**
  - **The mains plug is used to isolate the ventilator circuits electrically from the SUPPLY MAINS, not to position the ventilator so that it is difficult to operate the plug.**
  - **No modification of this equipment is allowed.**
  - **Do not touch the patient when connecting the peripheral equipment via the I/O signal ports or replacing the oxygen cell to prevent patient leakage current from exceeding the requirements specified by the standard.**
  - **RJ45 port is used for software upgrades by the personnel trained and authorized by us only. Do not connect it to other devices or internet.**
- 
- 

### **1.1.3 Cautions**

---

** CAUTION**

---

- **The ventilator must be inspected and serviced regularly by trained service personnel.**
  - **To ensure patient safety, always prepare pulmotor for use.**
  - **Always have a special person attend and monitor the operation of the equipment once the ventilator is connected to the patient.**
  - **During the operation of the ventilator, do not disassemble the expiration valve and expiratory flow sensor, which, however, can be disassembled in standby mode.**
- 
-

---

---

 **CAUTION**

---

- **To ensure patient safety, use only parts and accessories specified in this manual.**
  - **At the end of its service life, the equipment, as well as its accessories, must be disposed of in compliance with the guidelines regulating the disposal of such products.**
  - **Magnetic and electrical fields are capable of interfering with the proper performance of the equipment. For this reason make sure that all external devices operated in the vicinity of the equipment comply with the relevant EMC requirements. Mobile phone, X-ray equipment or MRI devices are a possible source of interference as they may emit higher levels of electromagnetic radiation.**
  - **This system operates correctly at the electrical interference levels identified in this manual. Higher levels can cause nuisance alarms that may stop mechanical ventilation. Pay attention to false alarms caused by high-intensity electrical fields.**
  - **Before connecting the equipment to the power line, check that the voltage and frequency ratings of the power line are the same as those indicated on the equipment's label or specified in this manual.**
  - **Always install or carry the equipment properly to avoid damage caused by drop, impact, strong vibration or other mechanical force.**
  - **The ventilator or its part should be positioned so that is easy to view.**
  - **The ventilator is intended to be used in the patient environment.**
  - **Additional MULTIPLE SOCKET- OUTLET or extension cord shall not be connected to the system.**
  - **When pushing the ventilator over the obstacles such as threshold, force the ventilator downwards to avoid getting tilted.**
-

---















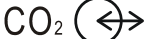













## 1.1.4 Notes







### NOTE

---

- Put the equipment in a location where you can easily see the screen and access the operating controls.
  - Keep this manual close to the equipment so that it can be obtained conveniently when needed.
  - The software was developed in compliance with IEC 60601-1-4. The possibility of hazards arising from software errors is minimized.
  - This manual describes all features and options. Your equipment may not have all of them.
-

## 1.2 Equipment Symbols

	Alternating current		Battery
	Equipotential		Fuse
RS-232 	RS-232 port	CO <sub>2</sub> 	CO <sub>2</sub> /calibration connection
O <sub>2</sub> ↑ 	O <sub>2</sub> ↑ button	O <sub>2</sub> % 	O <sub>2</sub> sensor connector
	Video input/output connection		VGA output connection
	Network connection		USB port
AIR 	Air supply connection	O <sub>2</sub> 	Oxygen supply connection
	Pneumatic outlet		Flow sensor
	Expiratory port		Inspiratory port
	Unlock		Nebulizer connection
	Compressor status indicator		Nurse call connection
AIR 	Compressed air outlet (of the compressor)	AIR 	Central pipeline gas supply inlet (of the compressor)
	Manufacture date		Manufacturer
	Serial number		Caution
	Type BF applied part. Defibrillation-proof protection against electric shock.	IP21	Degrees of protection provided by enclosure (IP Code)

	Refer to instruction manual/booklet		General warning sign
	No pushing		Protective earth (ground)
	<p>The following definition of the WEEE label applies to EU member states only. This symbol indicates that this product should not be treated as household waste. By ensuring that this product is disposed of correctly, you will help prevent bringing potential negative consequences to the environment and human health. For more detailed information with regard to returning and recycling this product, please consult the distributor from whom you purchased it.</p> <p>* For system products, this label may be attached to the main unit only.</p>		
	<p>The product bears CE mark indicating its conformity with the provisions of the Council Directive 93/42/EEC concerning medical devices and fulfils the essential requirements of Annex I of this directive.</p>		

# 2 The Basics

---

---

## 2.1 System Description

### 2.1.1 Intended Use

The Ventilator is intended to provide ventilation assistance and breath support for adult, pediatric and infant patients with respiratory insufficiency or respiratory failure in the hospital or other medical institutions. Ventilation may be delivered via mask or tracheotomy. This product must be operated by doctors, respiration therapist or other specially trained and authorized personnel. Anyone unauthorized or untrained must not perform any operation on it.

### 2.1.2 Contraindications

There are no absolute contraindications for this product. However, for some patients who suffer from special diseases, special ventilation is required or treatment has to be carried out before mechanical ventilation. Otherwise, hazards may be resulted.

### 2.1.3 Components

The ventilator consists of a main unit (including pneumatic circuit, electronic system, mechanical structure, software, display, CO2 module), cart, support arm, air compressor, and breathing hoses (refer to chapter *12 Accessories*).

Connect the patient to the ventilator via the patient breathing circuit.

The applied part of the ventilator is breathing masks.

---

## 2.2 Equipment Appearance

### 2.2.1 Front View

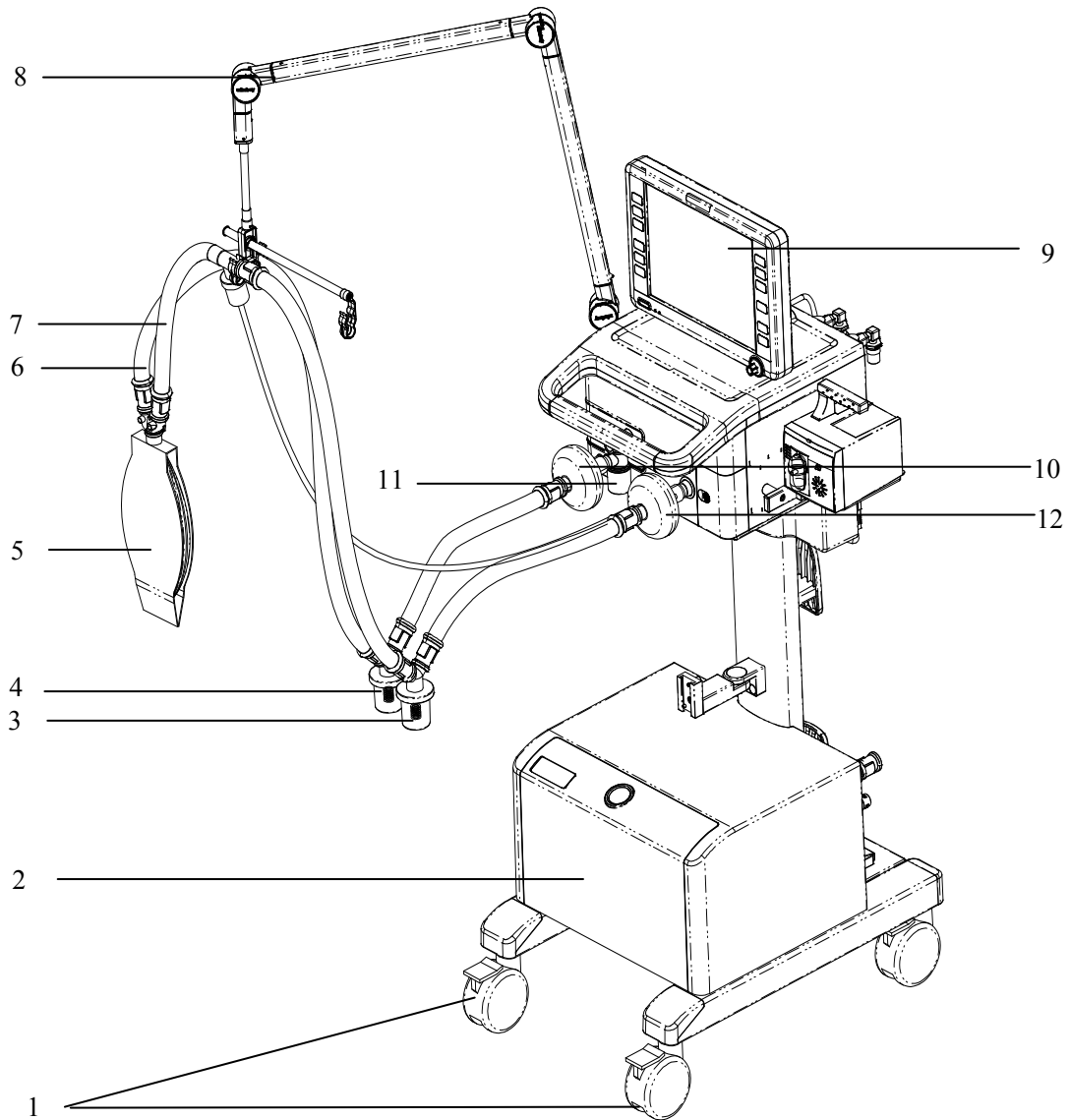



---

1. Caster and brake

The four casters of the ventilator have brakes.

2. Compressor

3. Inspiratory water trap

Collects condensed water in the hose.

4. Expiratory water trap

Collects condensed water in the hose.

5. Test lung

6. Expiratory hose

7. Inspiratory hose

8. Support arm

Supports the patient's breathing hoses.

9. Display

10. Expiratory filter

Prevents water and bacteria inside the patient hoses from entering the ventilator's internal pneumatic circuit.

11. Water trap at the expiratory port

12. Inspiratory filter

Prevents water and bacteria inside the patient hoses from entering the ventilator's internal pneumatic circuit.

---

## 2.2.2 Rear View

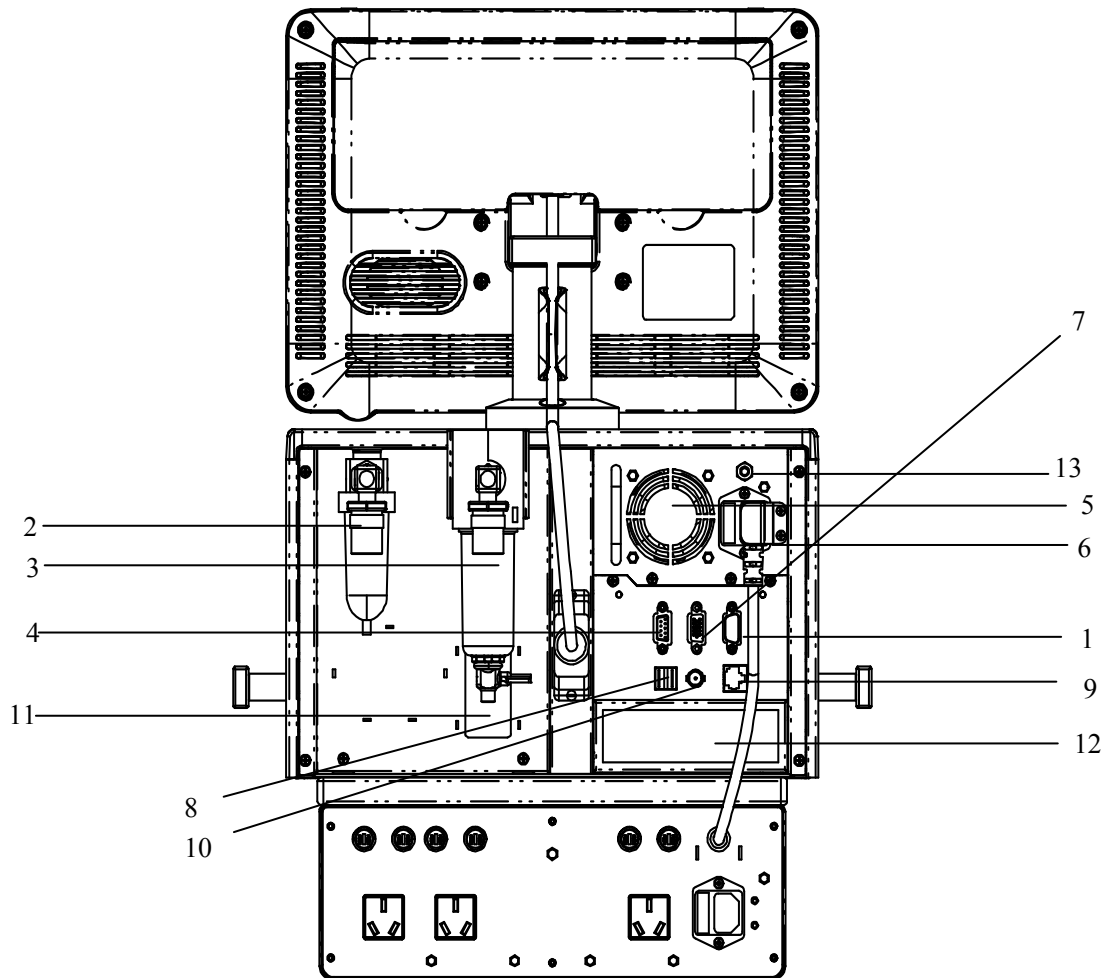

1. RS-232 port

Connects to the medical-grade external device via RS-232 protocol to implement the communication between the ventilator and external device.

2. Oxygen supply connection(with filter water trap)

3. Air supply connection(with filter water trap)

4. CO<sub>2</sub>/calibration connection

One multiplex connector for calibrating inspiratory and expiratory flows and supplying power for the external CO<sub>2</sub> analyzer.

5. Fan

6. AC mains inlet

7. VGA connection

The ventilator provides a D-Sub 15, female video output connector, which connects to an external display and outputs VGA visual signals same to the primary display. This

---

connection allows for interfacing to an externally located 24 bits, 800 x 600, SVGA monitor, which should be a medical grade monitor.

8. USB port

9. Network connection

One multiplex connector for network and software online upgrade.

10. Nurse call connection

Connects to the hospital's calling system and outputs nurse call signals when an alarm occurs.

11. Inspiratory dust filter

12. Fan filter (filter at air intake vent)

13. Equipotential stud / lug

Provides a ground point. Eliminates the ground potential difference between different devices to ensure safety.

### 2.2.3 Air Compressor

The air compressor has standby function. In the standby mode, the compressor starts to deliver compressed air to the ventilator automatically if the hospital central pipeline gas supply fails. The compressor stops delivering compressed air automatically when the central pipeline gas supply returns to normal.

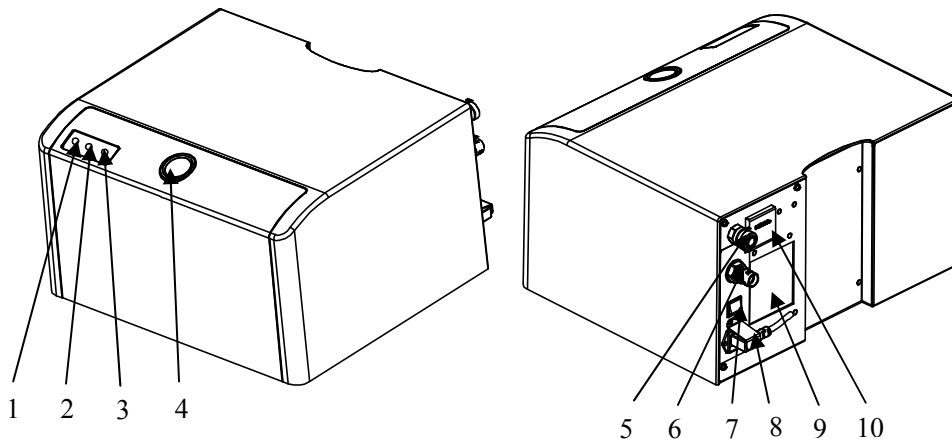

1. Power indicator

The power indicator is lit when the compressor is connected to power supply and the power switch is turned on.

2. Status indicator

The status indicator is lit when the central pipeline gas supply is applied.

---

3. Alarm indicator

The alarm indicator is lit when the compressor internal temperature is abnormally high. In this case, the compressor may shut off at any time and stop delivering gas.

4. Pressure gauge

The pressure gauge indicates the air pressure at the compressed air outlet.

5. Compressed air outlet

6. Central pipeline gas supply inlet

7. Power switch

8. Mains power inlet (with fixing pressure plate)

9. Air intake vent (with dust filter)

10. Hourmeter

The hourmeter indicates the accumulated running time of the compressor (not including the accumulated running time when the central pipeline gas supply is applied)

## NOTE

- 
- **Burn-in is required for the compressor before delivery. The reading indicated by the compressor hourmeter shall be less than 150 hours at the time of delivery.**
-

# 3 Installations and Connections

---

---

## WARNING

---

- Do not use antistatic or conductive masks or breathing hoses. They can cause burns if they are used near high frequency electrosurgical equipment.
  - To ensure optimum performance of the ventilator, re-do system check each time when accessories or components like hose, humidifier, and filter are replaced.
  - Adding accessories or other components to the ventilator can increase system inspiratory and expiratory resistance.
- 
- 

## 3.1 Install the Display

### 3.1.1 Install the Display onto the Ventilator

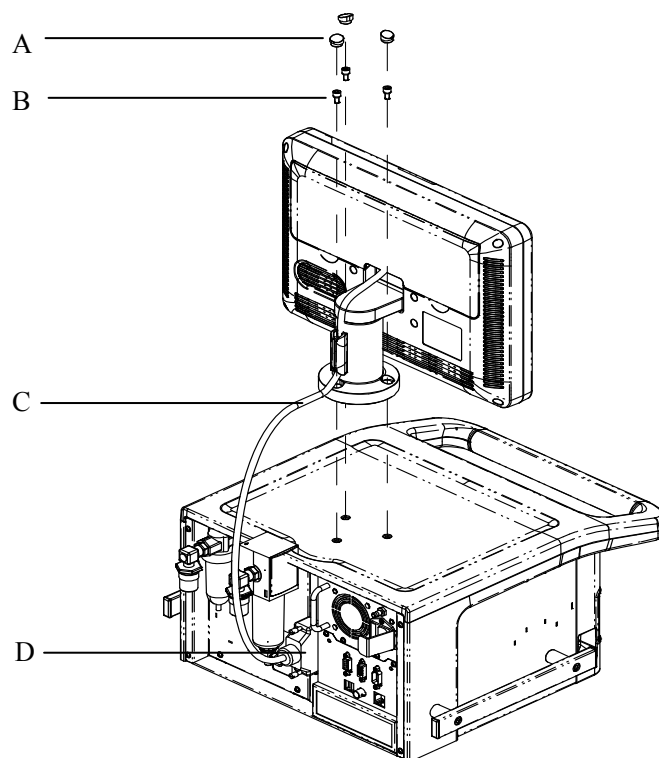

- A. Screw plug
- B. Screw
- C. Display connection line (with two fixing knobs)
- D. Video input/output connection

- 
1. Put the display onto the ventilator and align the display with the screw holes.
  2. Install the three screws to fix the display.
  3. Insert the three screw plugs.
  4. Connect the display connection line to the Video input/output port and tighten the two fixing knobs.

### 3.1.2 Install the Display onto the Pendant

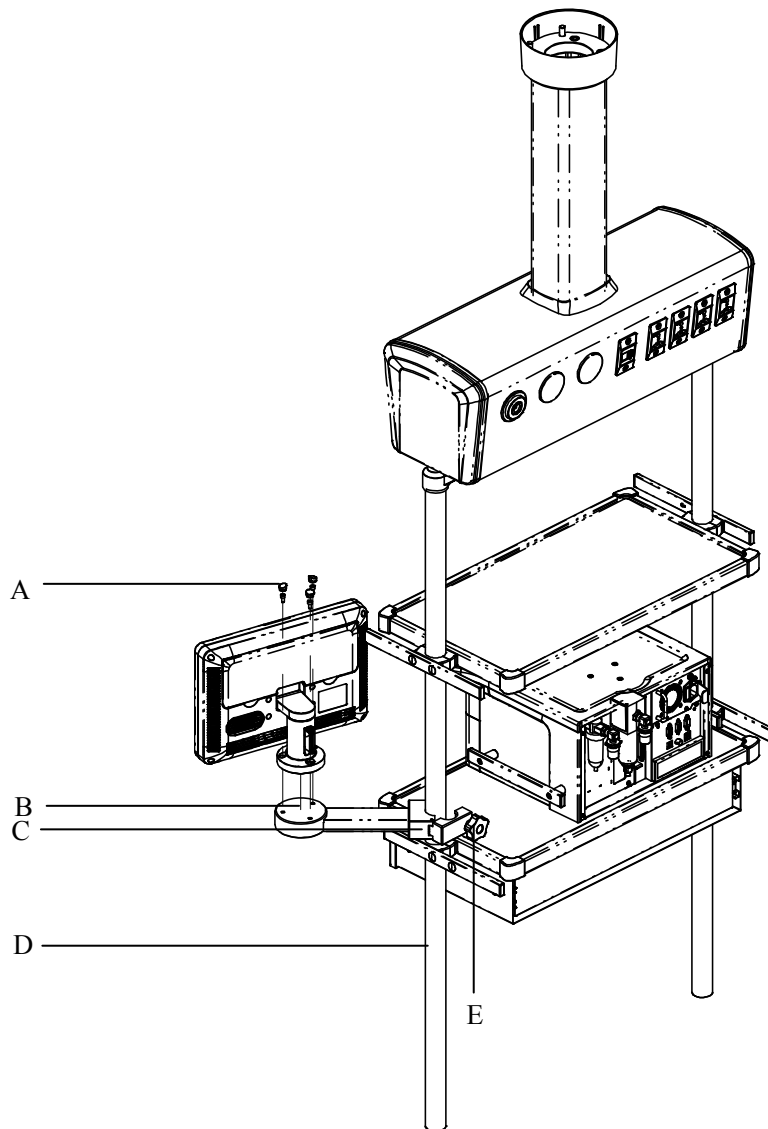

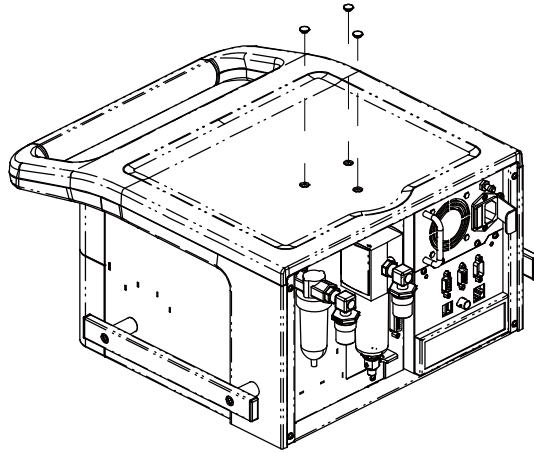
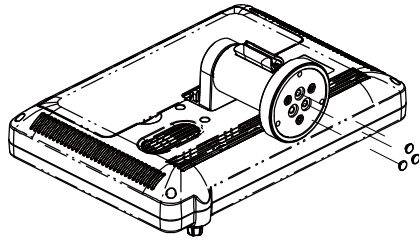

- A. Screw
  - B. Display bracket base disk
  - C. Fixing block
  - D. ICU pendant pole
  - E. Knob for fixing block
- 
1. Loosen the knob for fixing block. Put the fixing block onto the ICU pendant pole.
  2. Tighten the knob for fixing block.
  3. Put the display onto the display bracket base disk and align the display with the screw holes.
  4. Install three screws to fix the display.
  5. Put the three plugs under the display bracket into the three holes on the ventilator unit.
  6. Connect the display connection line to the main unit. For details, refer to step 4 of **3.1.1**.

---

## 3.2 Connect the Power Supply

### 3.2.1 Connect the System Power Supply

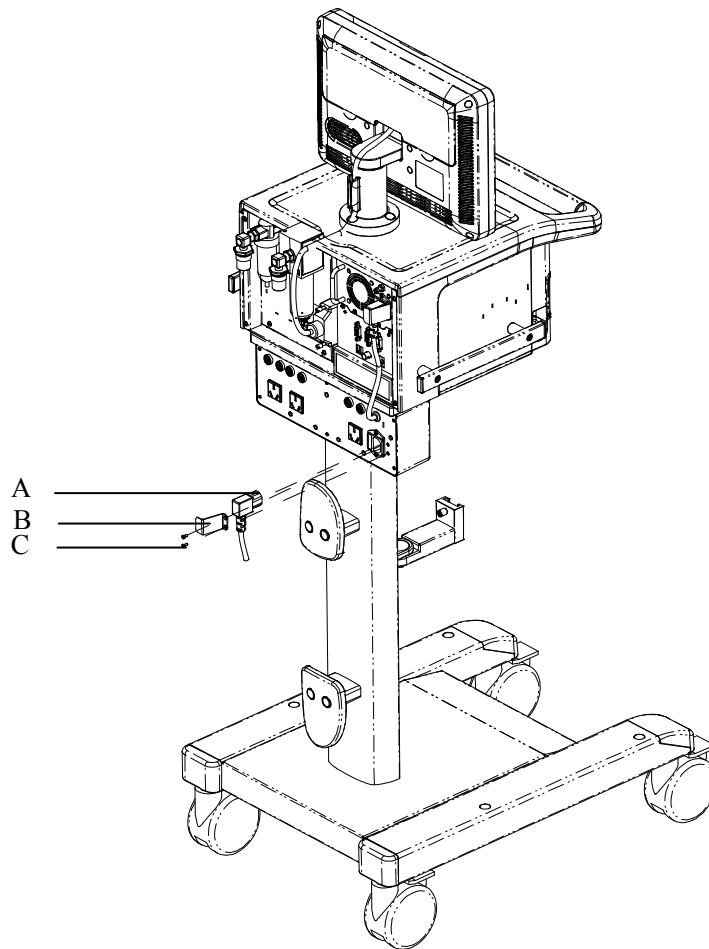

A. AC power cord      B. AC Power cord retainer      C. Screw

1. Plug the AC power cord into the AC power outlet.
2. Place the AC power cord retainer above the power outlet and align the retainer with the screw holes.
3. Tighten the two screws.



---

### 3.2.2 Connect the Main Unit Power Supply

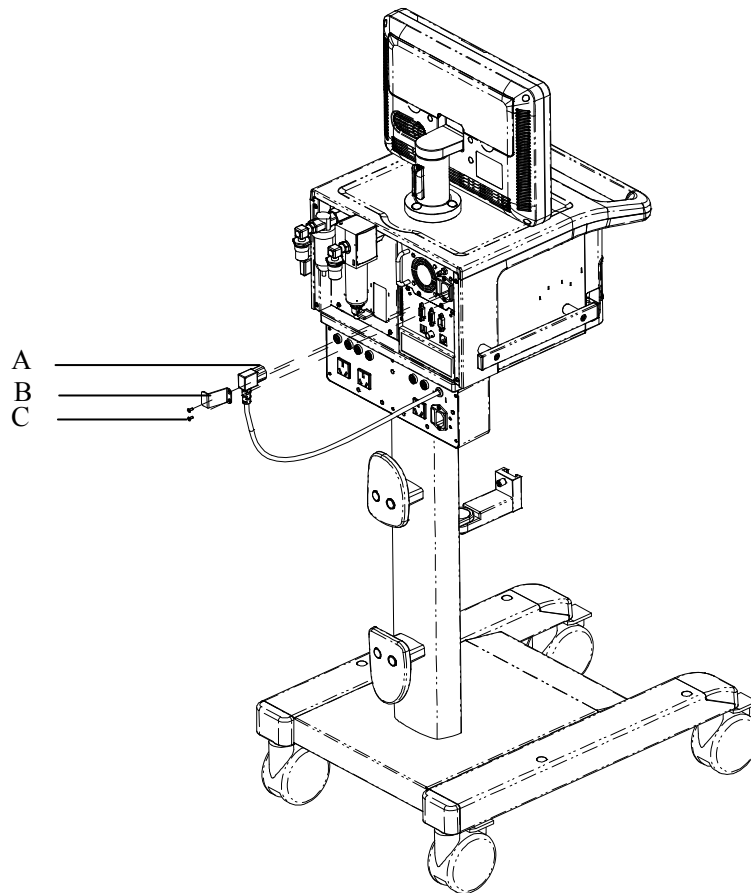

A. Main unit power cord    B. Main unit power cord retainer    C. Screw

1. Plug the main unit power cord into the power outlet.
2. Place the main unit power cord retainer above the power outlet and align the retainer with the screw holes.
3. Tighten the two screws.

---

### 3.2.3 Connect the Compressor Power Supply

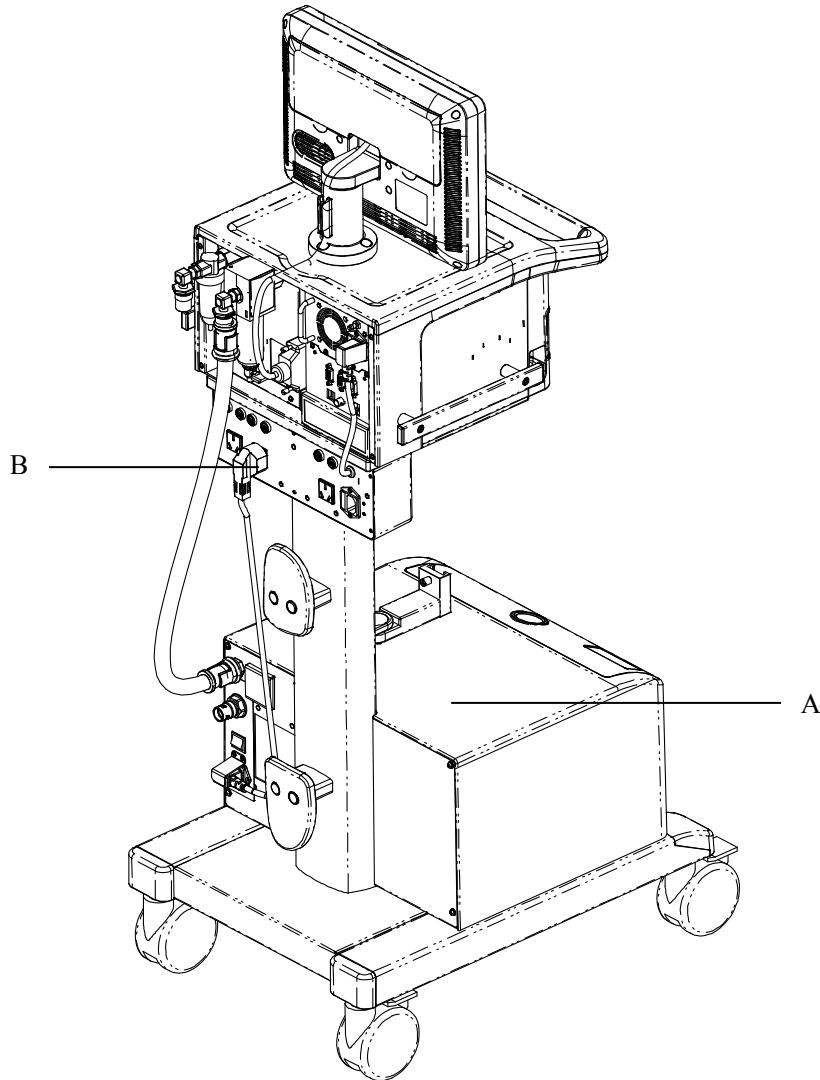

A. Compressor

B. Compressor power cord

Plug the compressor power cord into the auxiliary electrical outlet specially for compressor directly.

---

### 3.3 Connect the Gas Supply

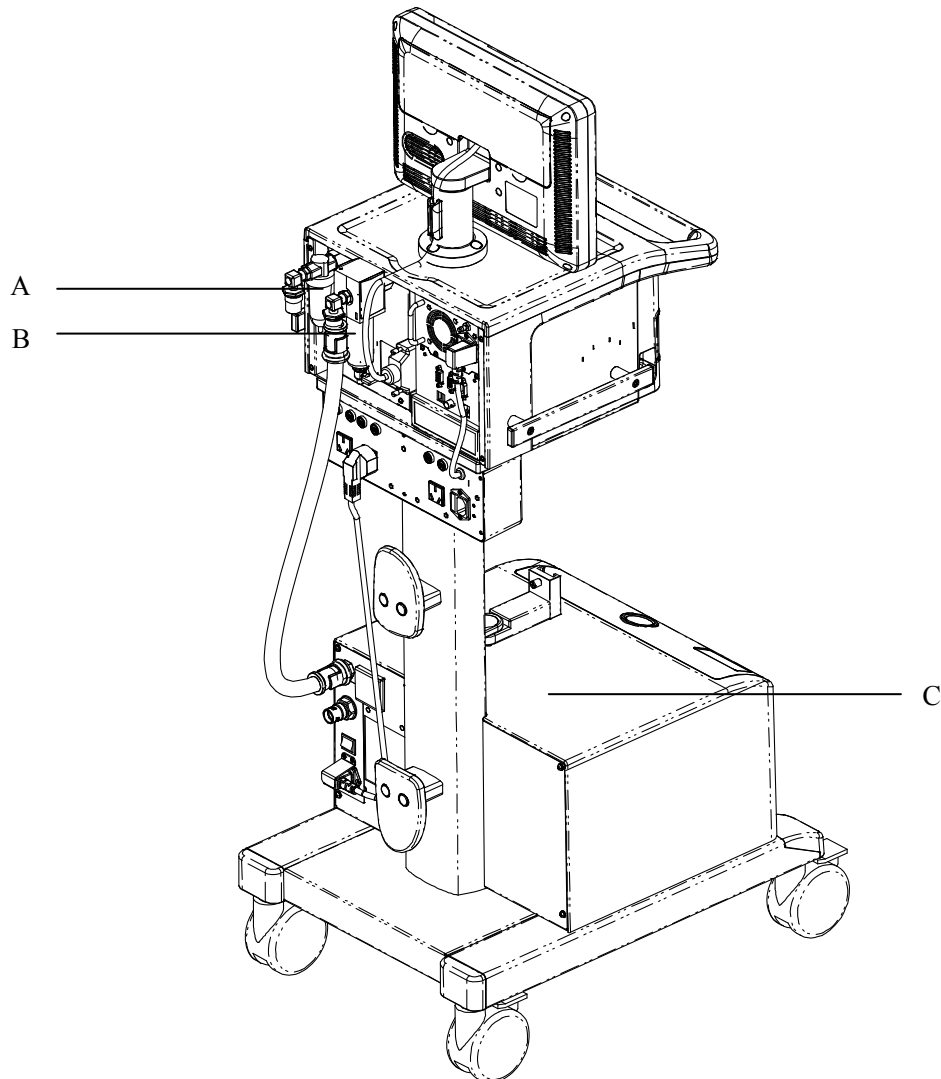

A. Oxygen supply connection      B. Air supply connection      C. Compressor

The ventilator provides two supply gas connections: oxygen and air. The supply gas hoses are differentiated by different colors. Do not attempt to switch oxygen and air supply connections.

Follow these steps to connect the oxygen and air supplies:

1. Check that the seals at the connectors are in good condition. If any damage is found, do not use the hose. Replace the defective seal to avoid leakage.
2. Plug the supply hoses and connectors into the corresponding supply connections at the rear of the ventilator.
3. Ensure that the supply hoses are properly connected. Screw the nut on the hose with hand.

The oxygen supply connection is connected to the hospital's central pipeline supply and the air supply connection can be connected to either the hospital's central pipeline supply or compressor's compressed air outlet.



---

3. Adjust the support arm.

- ◆ Support arm joint E or G: To adjust the bending angle of the support arm

downward, push and hold the blue button  on support arm joint E or G with one hand and hold the support bar and press it downward with the other hand.

Support arm joint E or G can be adjusted for up to 130°. To adjust the bending angle of the support arm upward, only lift the support bar to the desired position

with no need to push the blue button .

- ◆ Support arm joint F: pull support arm joint F upward or downward to the desired position.
- ◆ Hold the bottom of support arm or the support bar beside support arm joint G and push it leftward or rightward with force to rotate the support arm to the desired position.

4. Place the breathing hoses onto the hose hook.

## NOTE

---

- **Operate support arm joint E or G with both hands as shown below. Operate with only one hand will bring some risk.**



---

## 3.5 Install the Water Traps

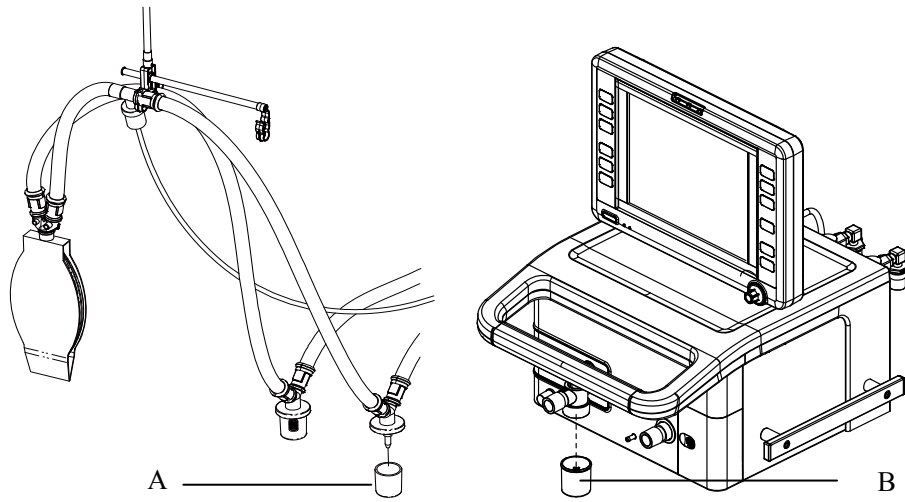

- A. Water trap on the breathing hose
- B. Water trap on the expiration valve assembly

Rotate to push in the water trap upward. Make sure that the water trap is installed in place.

---

## 3.6 Install the Breathing Hoses

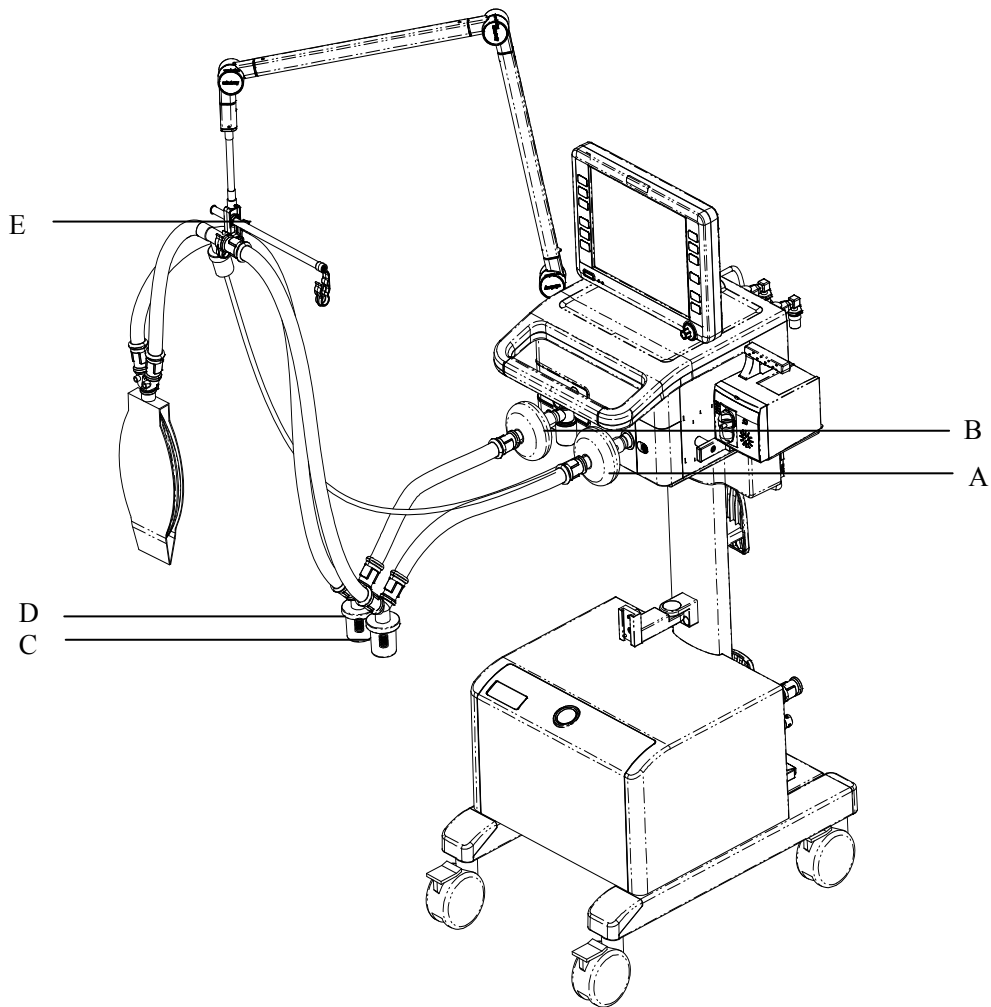

- A. Inspiratory filter
- B. Expiratory filter
- C. Inspiratory water trap
- D. Expiratory water trap
- E. Support arm hook

1. Mount the filters onto the inspiratory and expiratory ports.
2. Connect the inspiratory filter to the water trap via the hose. Connect the other end of the hose to the Y piece.
3. Connect the expiratory filter to the water trap via the hose. Connect the other end of the hose to the Y piece.
4. Place the breathing hoses onto the support arm hook.

---

## 3.7 Install the Humidifier

### Note

- 
- Install the humidifier which complies with the specification. The humidifier assembly and its installation steps described here are only for reference.
- 

### 3.7.1 Install the Humidifier onto the Ventilator

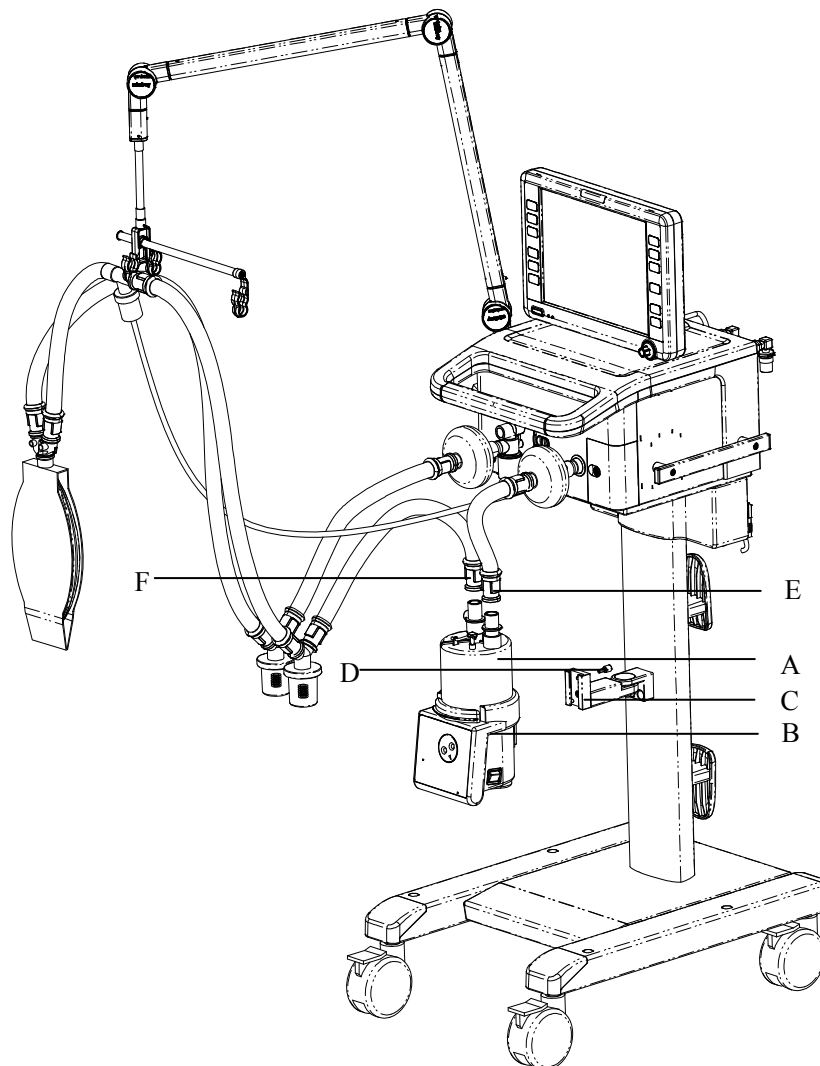

- |                                  |                             |
|----------------------------------|-----------------------------|
| A. Humidifier                    | B. Humidifier sliding wheel |
| C. Humidifier bracket fixed seat | D. Screw                    |
| E. Humidifier inlet              | F. Humidifier outlet        |

1. Align the humidifier sliding wheel with the humidifier bracket fixed seat and slide in the humidifier.
2. Tighten the screw.



- 
3. Mount the filters onto the inspiratory and expiratory ports.
  4. Connect the inspiratory filter to the humidifier inlet via the hose.
  5. Connect the humidifier outlet to the water trap via the hose. Then, connect the water trap to the Y piece via the hose.
  6. Connect the expiratory filter to the water trap via the hose. Then, connect the water trap to the Y piece via the hose.
  7. Place the breathing hoses onto the support arm hook.

The rated range of the ventilator breathing system (VBS):

Inspiratory and expiratory gas pathway resistance: 0~6cmH<sub>2</sub>O/ (L/s) at 60L/min

VBS compliance: 0~5ml/cmH<sub>2</sub>O

---

### 3.7.2 Install the Humidifier onto the Pendant

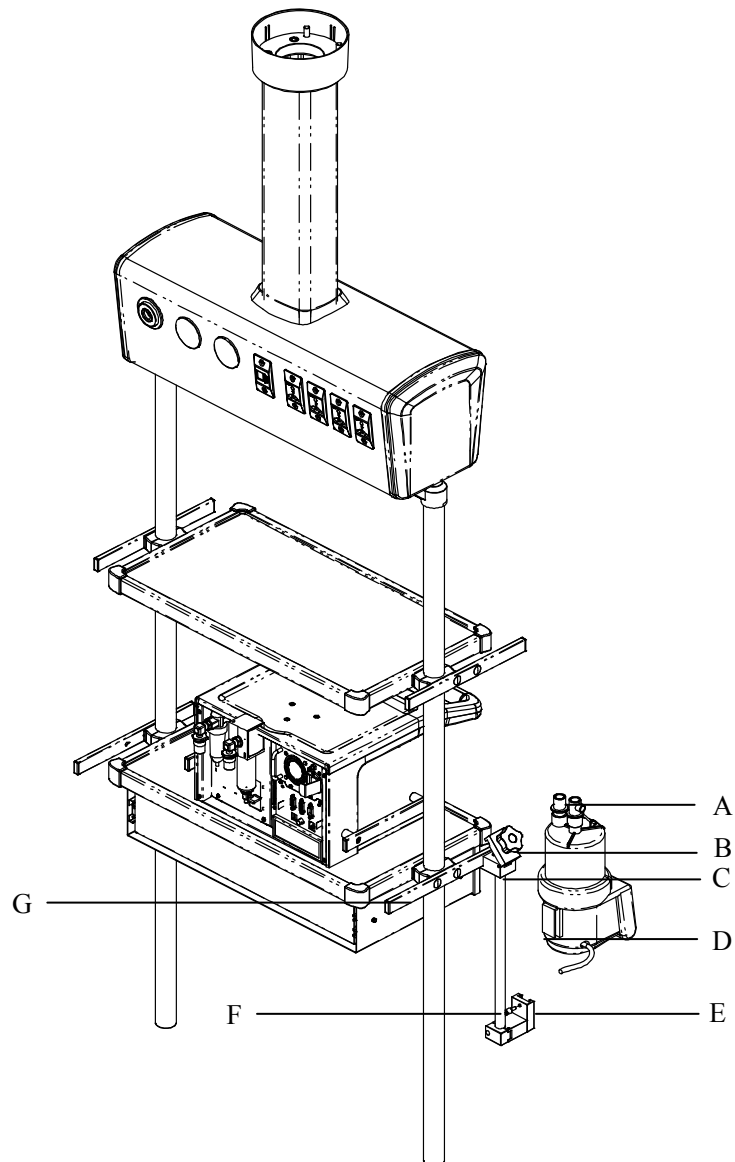

- A. Humidifier      B. Knob for fixing block      C. Fixing block  
D. Humidifier sliding wheel      E. Humidifier bracket fixed seat      F. Screw  
G. Beam

1. Loosen the knob for fixing block. Put the fixing blocking onto the pendant beam.
2. Tighten the knob for fixing block.
3. Align the humidifier sliding wheel with the humidifier bracket fixed seat and slide in the humidifier.
4. Tighten the screws.
5. Install the breathing hoses. For details, refer to steps 3 through 7 in **3.7.1**.

---

---

**⚠ WARNING**

---

- When installing the humidifier, make sure that the humidifier connector shall be lower than the ventilator's breathing connectors and the patient when installing the humidifier.
- 

### 3.8 Install the Nebulizer

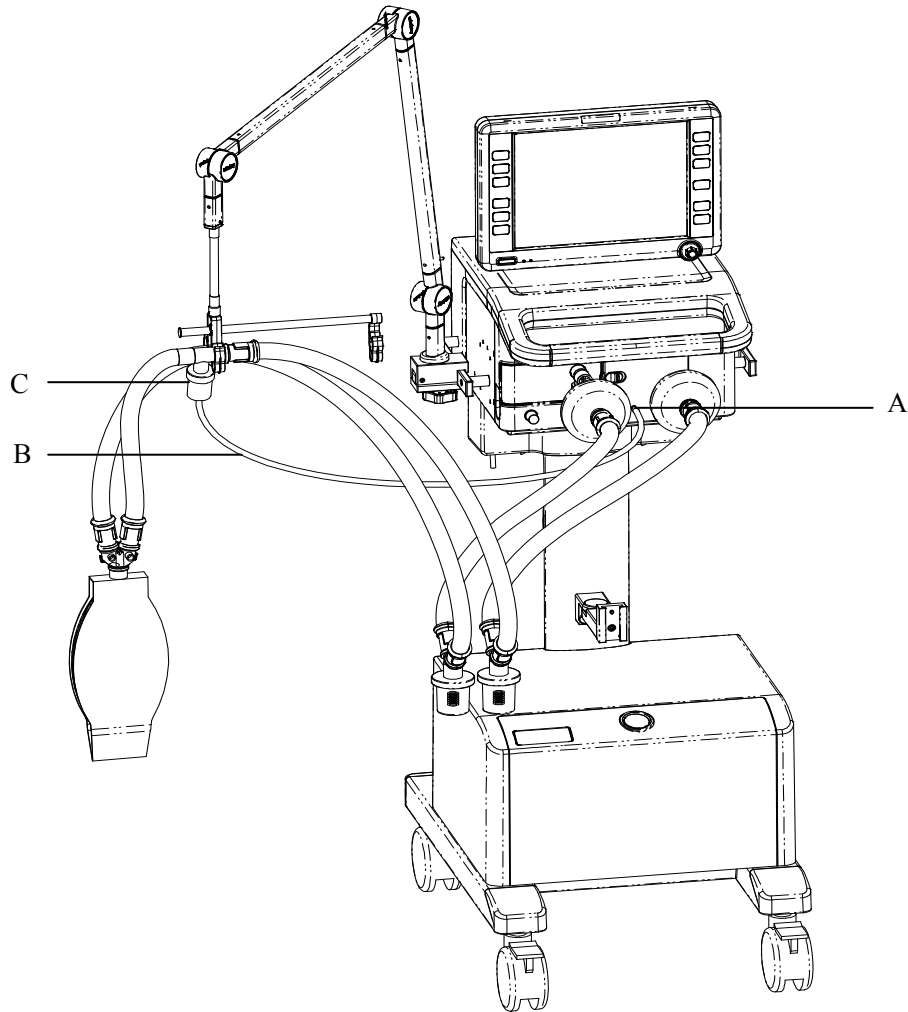

A. Nebulizer connector      B. Nebulizer hose      C. Nebulizer

1. Connect one end of the nebulizer hose to the nebulizer connector and the other end of the hose to the nebulizer.
2. Mount the nebulizer onto the inspiratory hose via the hose.

#### Note

- The nebulizer assembly and its installation steps described here are only for reference.
-

---

---

**⚠ WARNING**

---

- Nebulization yields the best performance at flow of 6 L/min. Nebulizers with other flows can create significant errors in tidal volume and oxygen mix.
- 

### 3.9 Install the CO<sub>2</sub> Module

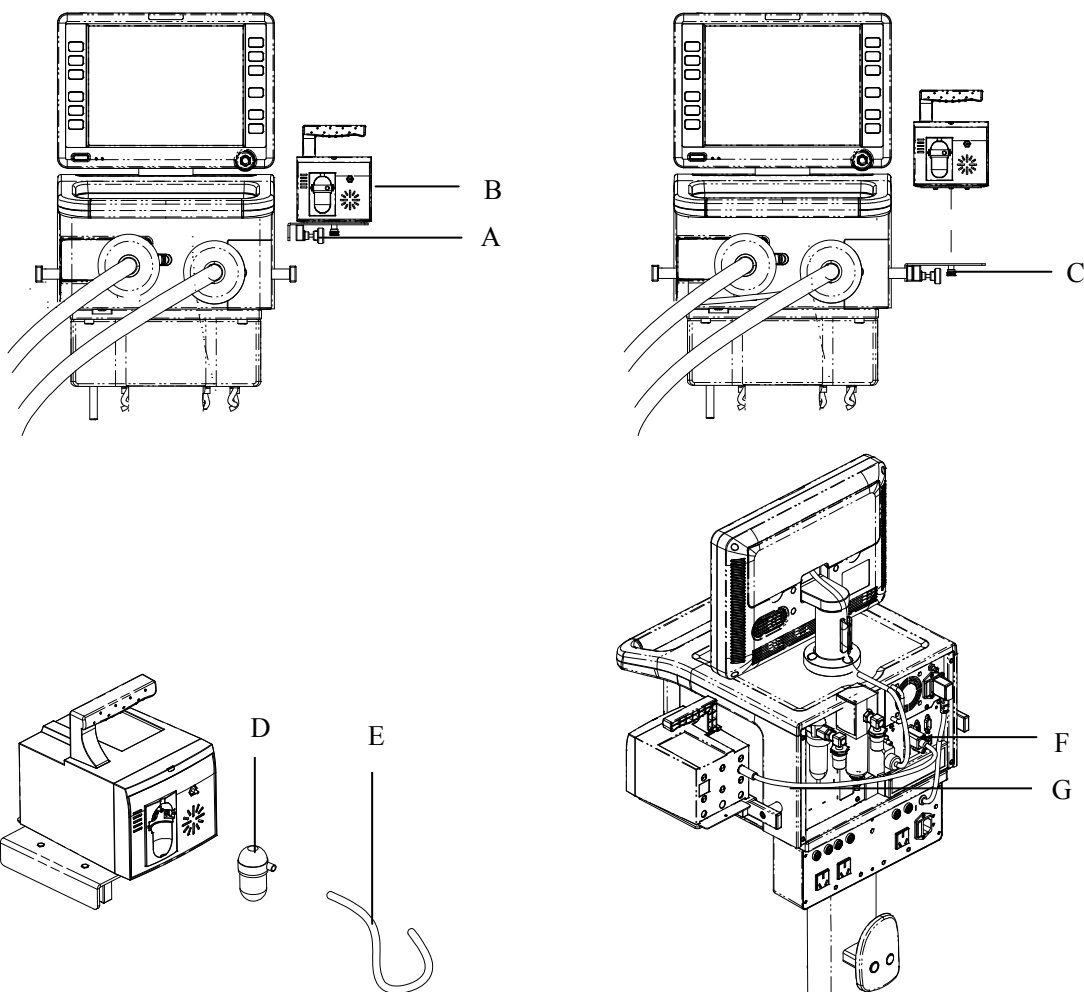

- A. Fastening screws for CO<sub>2</sub> module mounting plate  
B. CO<sub>2</sub> module  
C. Fastening screws for CO<sub>2</sub> module  
D. Water trap  
E. Sampling line  
F. CO<sub>2</sub>/calibration connection  
G. CO<sub>2</sub> module connection line

1. Place the CO<sub>2</sub> module mounting plate onto the ventilator's handle. Then tighten the fastening screws.

- 
2. Place the CO2 module onto the mounting plate and align with the screw holes. Then tighten the three fastening screws.
  3. Connect the connection line at the back of the CO2 module to the ventilator's CO2/calibration connection.
  4. Connect one end of the sampling line to the water trap and then mount the water trap onto the CO2 module. Connect the other end of the sampling line to the patient.

### 3.10 Install the O2 Sensor

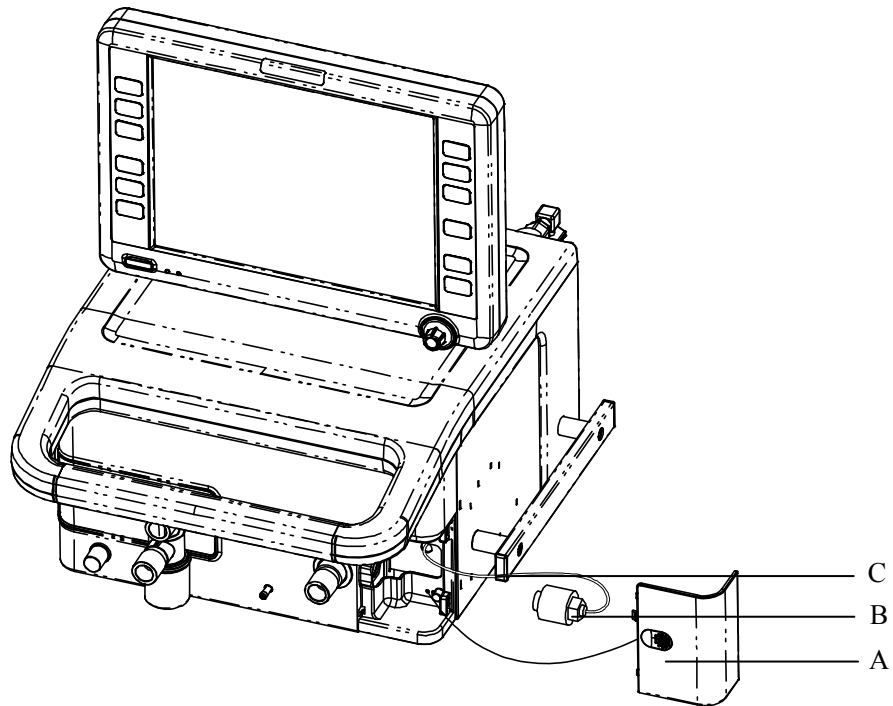

- A. O2 sensor door                      B. O2 sensor                      C. O2 sensor connection line

1. Screw on the O2 sensor clockwise.
2. Plug in the O2 sensor connection line.
3. Buckle the O2 sensor door.

---

**FOR YOUR NOTES**

# 4 User Interface

---

## 4.1 Display Controls

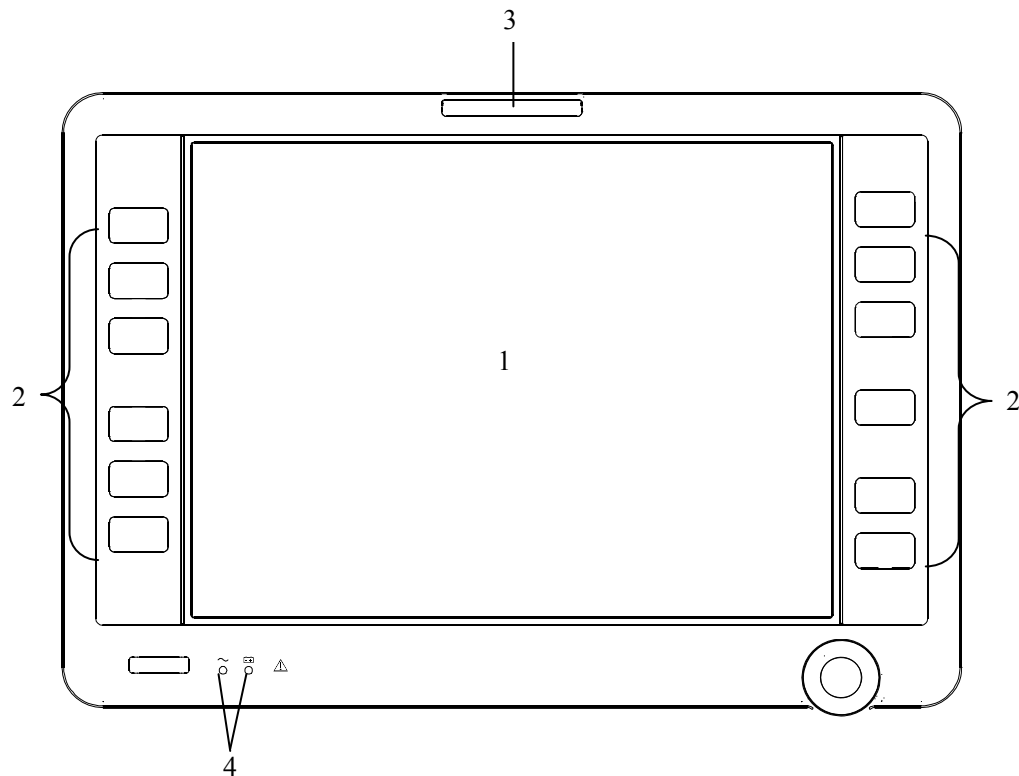

The control unit is characterized by the small number of operating elements. Its main elements are:

1. Display (touch screen)

The display shows the software screen of the ventilator system. You can select and change settings by touching the screen.



2. Fixed hard keys

The fixed hard keys are provided for rapid access to the ventilator's major functions.

3. Alarm LED

The alarm LED indicates the priority of an active alarm by flashing different colors at different frequencies.

#### 4. AC power LED and battery LED

-  indicates the AC power LED.
  - ◆ Lit: when the ventilator is connected to the AC power source.
  - ◆ Extinguished: when the ventilator is not connected to the AC power source.
-  indicates the battery LED.
  - ◆ Lit: when the battery is being charged or is already fully charged and the ventilator is operating on AC power source.
  - ◆ Flash: when the ventilator is operating on battery power.
  - ◆ Extinguished: when the ventilator is not connected to the AC power source, or the ventilator is not equipped with battery, or the ventilator battery is faulty.





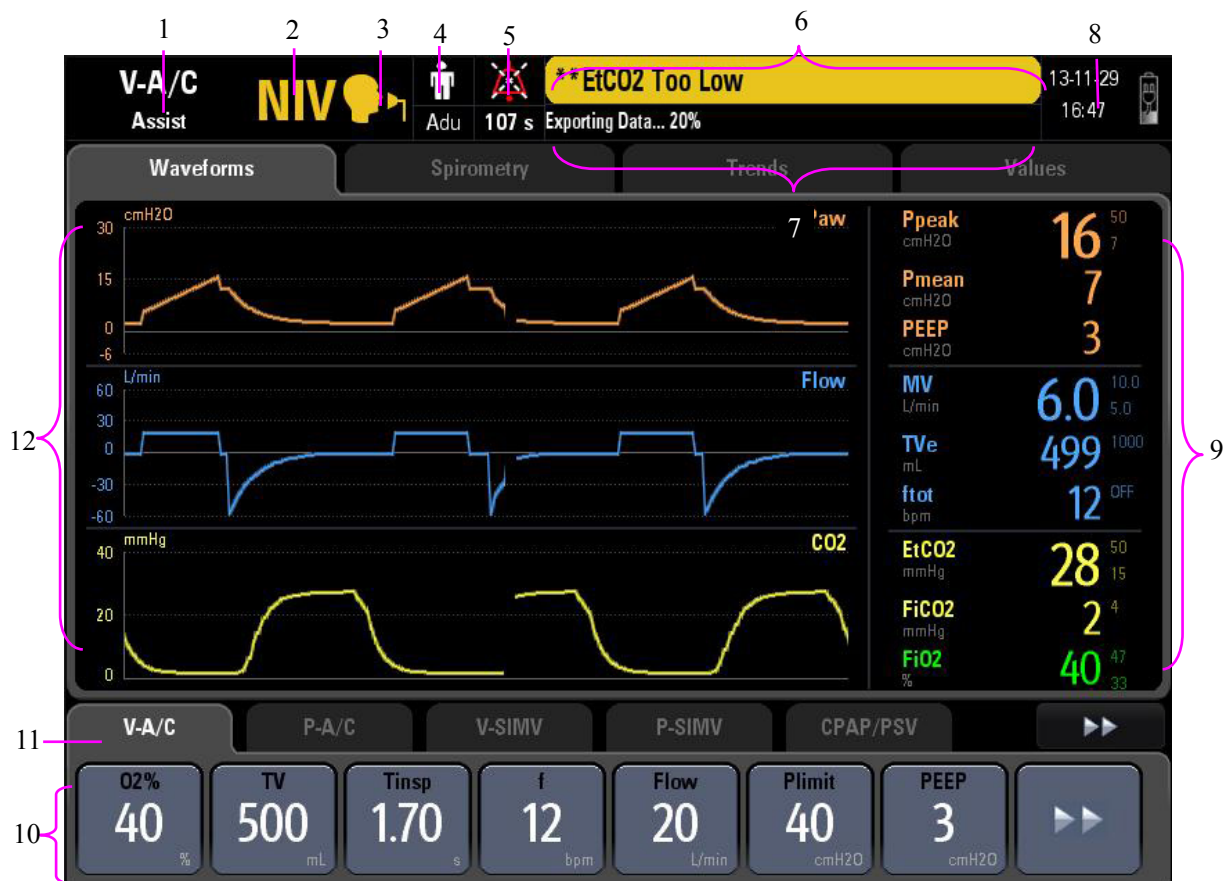

### 4.1.1 Display

The ventilator display shows ventilation parameters, pressure/flow/volume waveforms and spirometry loops etc.

The following is an example of waveforms screen. Display screen may vary subject to the configurations.





- 
1. Ventilation mode field  
Displays Standby or active ventilation mode, and ventilation assist.
  2. NIV/ intubation icon field  
Displays NIV when it is non-invasive ventilation, or intubation icon  when it is invasive ventilation.
  3. Mask/ ATRC and pipe diameter field  
Displays mask icon  when it is non-invasive ventilation, or blank when it is invasive ventilation and dynamic tube compensation is turned off, or ATRC and pipe diameter when it is invasive ventilation and dynamic tube compensation is endotracheal intubation or tracheotomy intubation.
  4. Patient type/inspiratory trigger field  
Indicates current patient type--adult () or pediatric (). The corresponding text prompt is displayed underneath the icon. The icon for inspiratory trigger is , which is prompted for one second.
  5. Alarm silence symbol and countdown field  
Displays the time remaining in the 120s alarm silence period and alarm silence symbol  as well.
  6. Alarm message field  
Displays the active alarm message. When there are multiple alarm messages, the system displays the symbol . Select the alarm message field at this moment to access the [**Current Alarm**] menu which displays all current alarm messages, alarm occurrence time, and alarm priority.
  7. Prompt message field  
Displays the active prompt message.
  8. System time/battery  
Displays current system time and battery status.
  9. Parameter field  
Displays measured parameters values of the ventilator.
  10. Parameter setup quick key field  
Displays ventilation setting parameters for the current mode of ventilation.

---

11. Ventilation mode setup field

Displays keys for setting ventilation mode.

12. Waveforms/spirometry/trends/measured values field

Displays waveforms, spirometry loops, graphic trend, tabular trend, or measured values.

### 4.1.2 Fixed Hard Keys

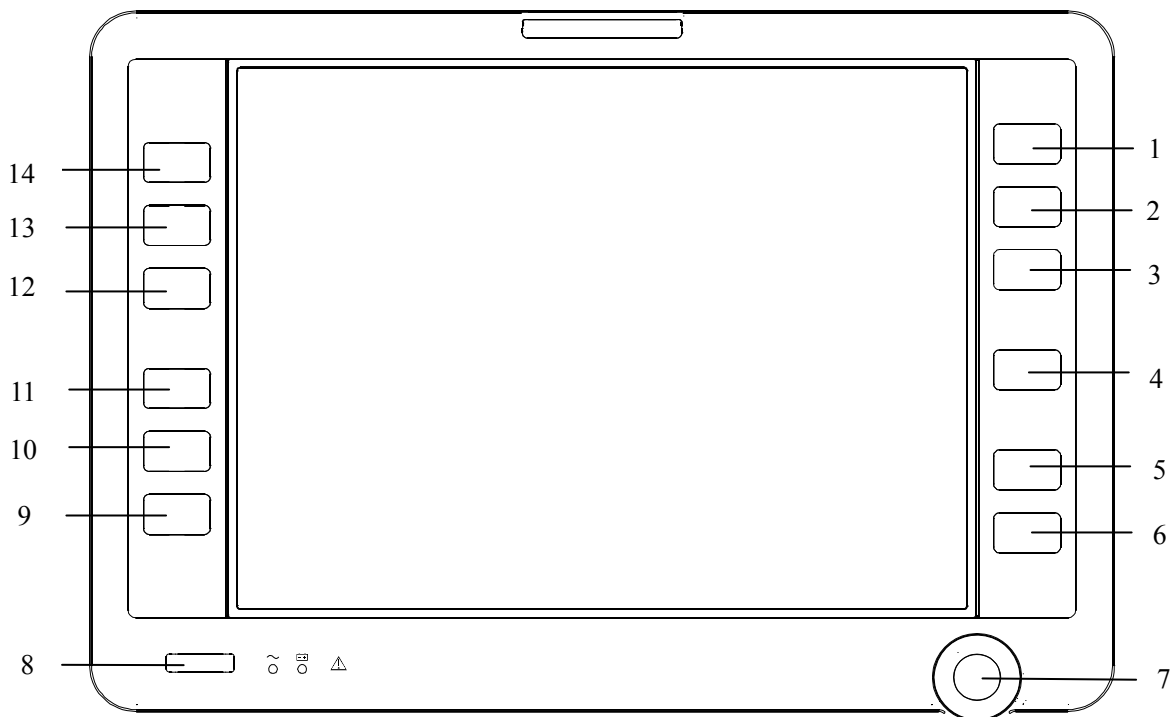

1. Alarm Silence key

Push to silence alarm audio of an active alarm for 120 seconds. When 120 seconds expires, the system exits alarm silenced status automatically and resumes alarm audio. If a new alarm occurs during the alarm silenced period, the system exits alarm silenced status automatically and gives alarm audio. In alarm silenced status, push this key to clear alarm silence.

2. Alarm Reset key

When there are latched alarms, if the alarm conditions disappear, push to clear all latched alarms.

---

Latching alarms: the system continues displaying the alarm message even if the alarm conditions end except that:

- ◆ Alarm audio disappears;
- ◆ Alarm LED stops flashing and is permanently lit with the same color;
- ◆ Alarm message is displayed without background color;
- ◆ The alarmed parameter measured value stops flashing.

3. Alarm Setup key

Push to access the alarm setup menu to set parameter alarm limits, alarm volume etc.

4. Standby key

Push to pop up a dialog box to confirm whether to enter Standby.

5. Freeze key

Push to enter or cancel freeze status. For details, refer to *4.7 Freeze*.

6. Menu key

Push to open system main menu or close screen menu.

7. Control knob

Push the control knob to select a menu option or confirm your setting. Turn the control knob clockwise or counterclockwise to scroll through the menu options or change your settings.

8. System switch

Push and hold/push the system key to turn on/off the system.

9. Manual Breath Key

Push to deliver manual ventilation.

10. Exp. Hold key

In non-standby status, push and hold this key to allow the patient to remain in expiration status and prevent the patient from inspiration. The screen shows [**Exp. Hold Active**]. Expiration Hold is active for a maximum of 30 seconds.

11. Insp. Hold key

In non-standby status, push and hold to allow the patient to remain in inspiration status and prevent the patient from expiration. The screen shows [**Insp. Hold Active**]. Inspiration Hold is active for a maximum of 30 seconds.



12. Nebulizer key

Push to access nebulizer related menu and start nebulization after completing the relevant settings. The LED in the upper left corner of this key is lit.

13. O<sub>2</sub> ↑ key/suction

In non-standby status, push to start O<sub>2</sub> ↑ function and the LED in the upper left corner of this key is lit. The screen shows the remaining O<sub>2</sub> ↑ time. When O<sub>2</sub> ↑ is active, push this key again to stop O<sub>2</sub> ↑. During O<sub>2</sub> ↑, removing the breathing hoses enters suction screen.

14. 

When pushed, the LED in the upper left corner of this key is lit and the ventilator enters locked status. The prompt message field displays [**Panel Locked. Push the Lock key to unlock the panel**]. During this period, only the Alarm Reset key, Alarm Silence key, Manual Breath key, O<sub>2</sub> ↑ key, and  key are enabled while the touchscreen and other fixed hard keys are disabled. Push the  key again to unlock.

## 4.2 Waveforms Screen

Select [**Waveforms**] to access the waveforms screen as shown below.

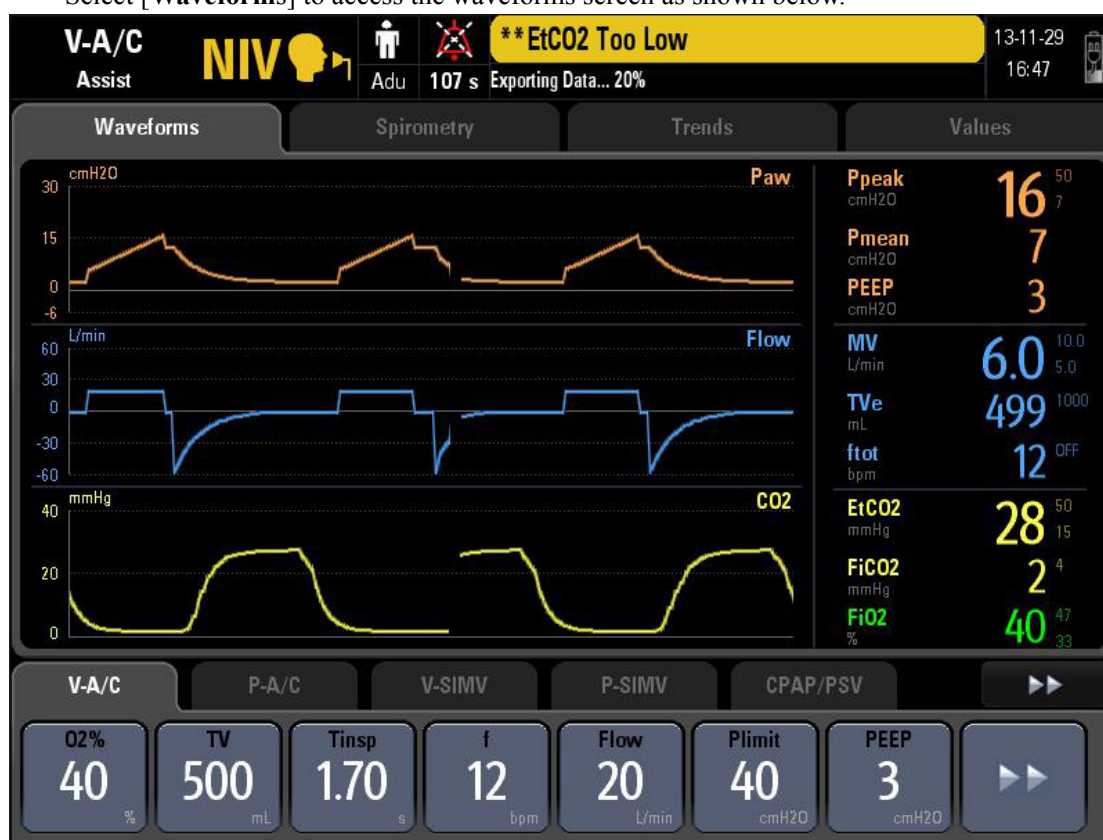

## 4.3 Spirometry Loops Screen

Select [**Spirometry**] to access the spirometry loops screen as shown below.

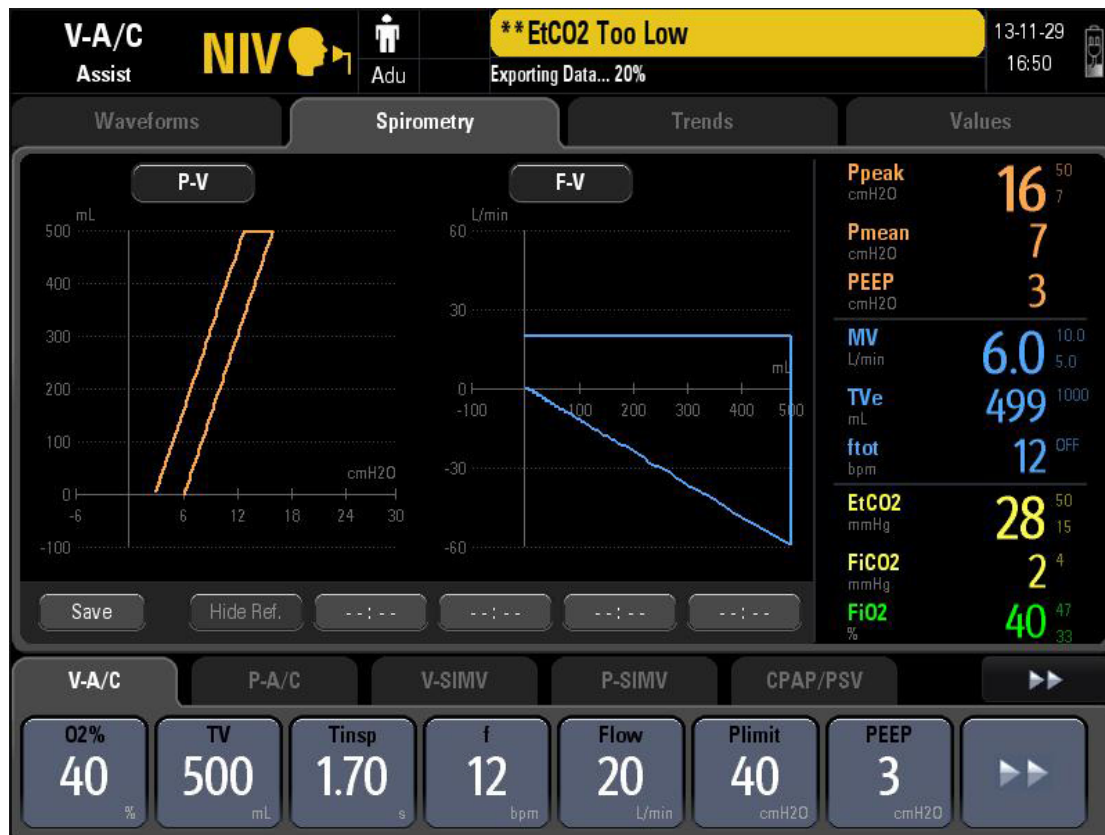

Spirometry loops reflect patient lungs function and ventilation condition as well, such as the patient's lungs compliance, over-inflation, breathing system leakage and airway blockage.

The system provides three types of spirometry loops: P-V (pressure-volume) loop, F-V (flow-volume) loop, and F-P (flow-pressure) loop. The three types of loops come from pressure, flow, and volume waveforms data.

Up to two types of spirometry loops are displayed at a time. To select the desired loop:

1. Select [**Spirometry**] on the main screen.
2. Select the desired loop to be displayed.

The ventilator provides the function of reference loop. Selecting [**Save**] saves the current F-V loop, P-V loop, and F-P loop as reference loop and displays the time on which the reference loop is saved. Selecting the time button views the reference loop saved at that time moment. Selecting [**Hide Ref.**] hides the reference loop which is being displayed.

The ventilator saves reference loops at up to four time moments. If reference loops at four

time moments are already saved, when [Save] is selected again, the system automatically clears the oldest reference loops except the loops being viewed and saves the current loops as reference loops.

## 4.4 Graphic Trend Screen

Graphic trend depicts the changes in parameter measured values in graphic form over a specific period of time. Each point on the curved line represents the physiological parameter value at each time moment.

You can access the following graphic window by selecting [Trends] and/or selecting the button for switching between [Tabular] and [Graphic].

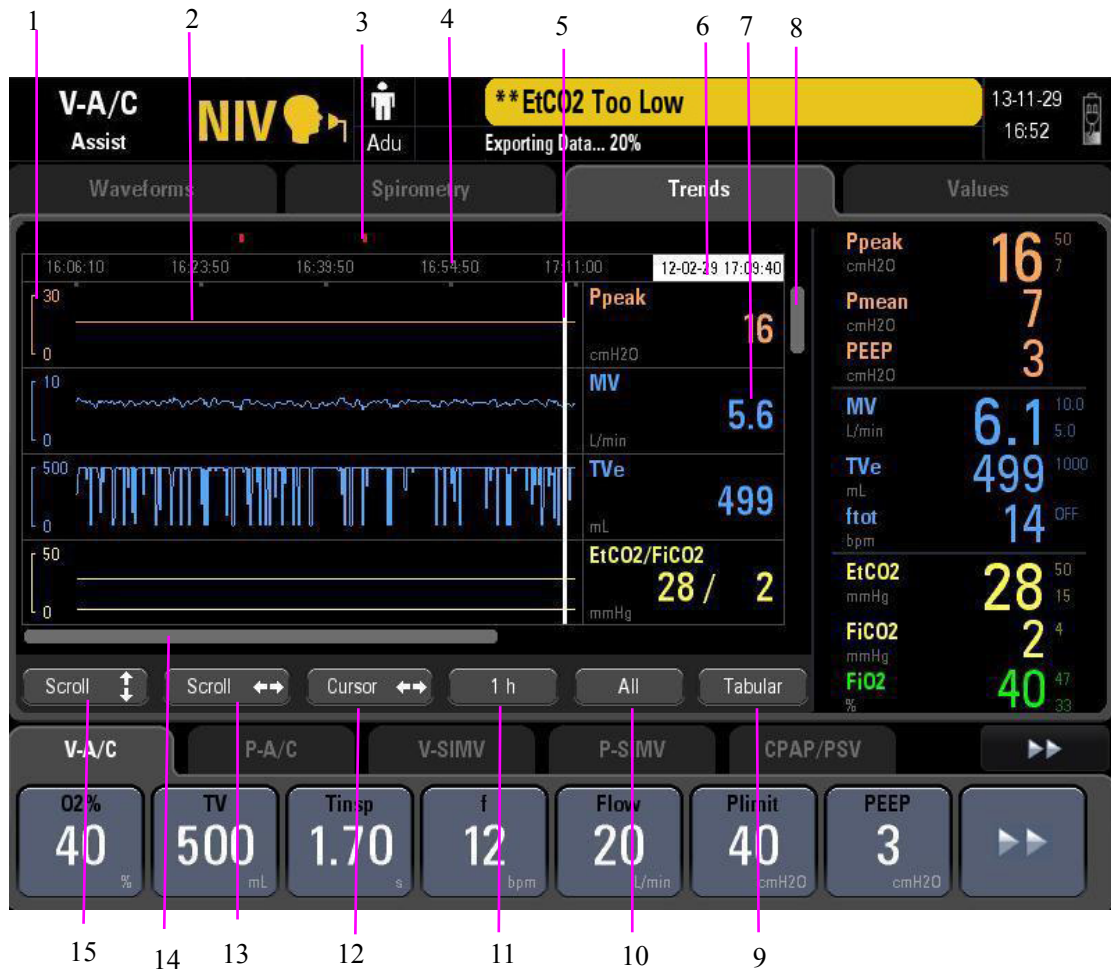

1. Graphic scale
2. Graphic trend
3. Event mark field, displaying event marks in the current trend window. Alarm events of different priorities are represented by different mark colors. Red event mark indicates a high priority alarm event and yellow a medium or low priority alarm event.
4. Time scale axis, displaying time scale information on the time axis.

- 
5. Cursor
  6. Time field, displaying the time corresponding to the cursor.
  7. Parameter area, displaying parameter values at the time corresponding to the cursor.
  8. Vertical scroll bar, indicating the position of the currently displayed parameter in the entire parameter sequencing.
  9. Button for switching between graphic trend and tabular trend
  10. Button for parameter grouping. Options are [**All**], [**Pressure**], [**Volume**], [**Time**] and [**Other**]. [**Pressure**] parameters include Ppeak, Pplat, Pmean, and PEEP. [**Volume**] parameters include TVi, TVe, TVe spn, MV, MVspn, and MVleak. [**Time**] parameters include ftot, fmand, and fspn. [**Other**] parameters include Ri, Re, Cdyn, RSBI, WOB, FiO2, FiCO2 and EtCO2.
  11. Window time button, which can be set to 1h, 3h, 6h, 12h, 24h, 48h, and 72h.
  12. Cursor control button for moving the cursor left or right.
  13. Horizontal scroll bar control button for moving the horizontal scroll bar left or right.
  14. Horizontal scroll bar, indicating the position of the currently displayed trend data in the entire trend database.
  15. Vertical scroll bar control button for moving the vertical scroll bar up and down.

## 4.5 Tabular Trend Screen

Tabular trend depicts the changes in parameter measured values in tabular form over a specific period of time.

You can access the following tabular window by selecting [**Trends**] and/or selecting the button for switching between [**Tabular**] and [**Graphic**].

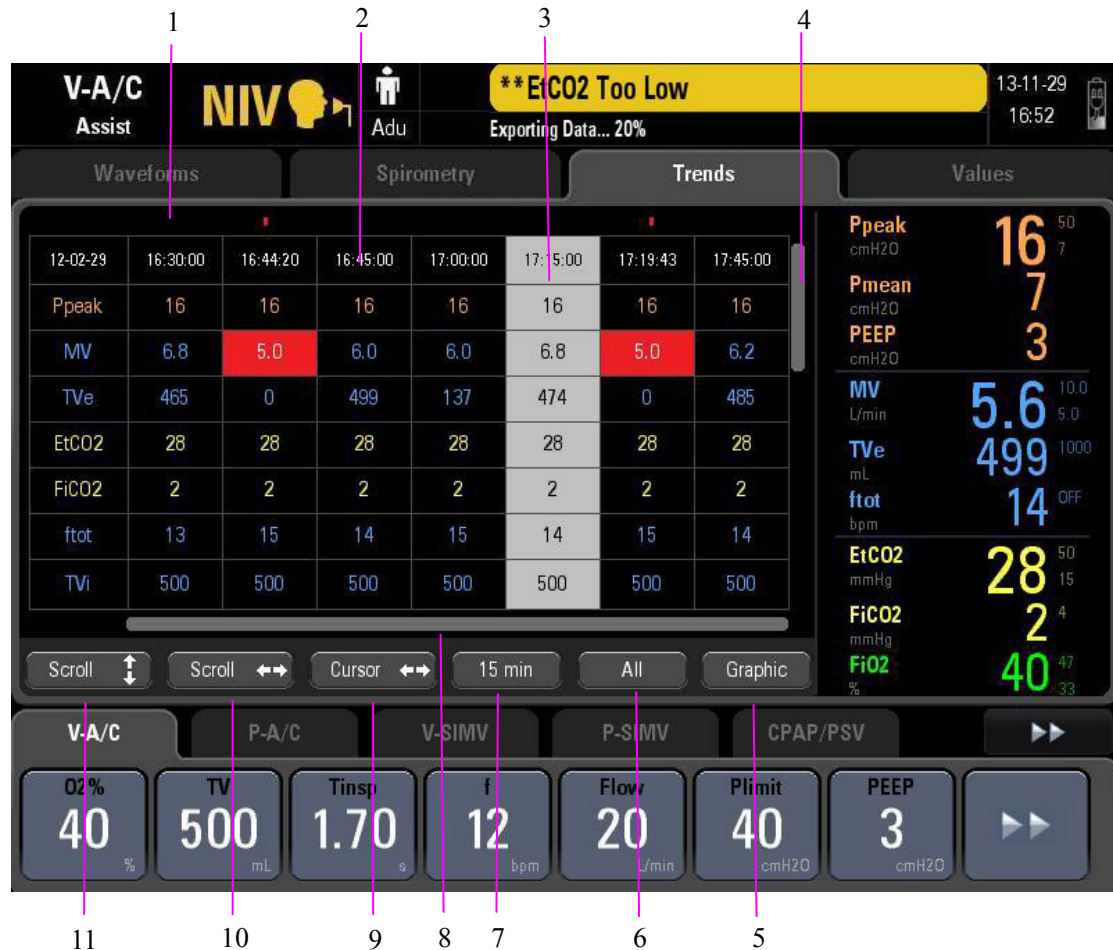

1. Event mark field, displaying event marks in the current trend window. Alarm events of different priorities are represented by different mark colors. Red event mark indicates a high priority alarm event and yellow a medium or low priority alarm event.
2. Time field, displaying the time corresponding to the cursor
3. Cursor column, displaying parameter values measured at the time corresponding to the cursor. Alarm events of different priorities are represented by different background colors. Red event mark indicates a high priority alarm event and yellow a medium or low priority alarm event.
4. Vertical scroll bar, indicating the position of the currently displayed parameter in the entire parameter sequencing.
5. Button for switching between graphic trend and tabular trend



6. Button for parameter grouping. Options are [All], [Pressure], [Volume], [Time] and [Other]. [Pressure] parameters include Ppeak, Pplat, Pmean, and PEEP. [Volume] parameters include TVi, TVe, TVe spn, MV, MVspn, and MVleak. [Time] parameters include ftot, fmand, and fspn. [Other] parameters include Ri, Re, Cdyn, RSBI, WOB, FiO2, FiCO2 and EtCO2.
7. Resolution button, which can be set to 1 min, 5 min, 10 min, 15 min, 30 min, and 1h.
8. Horizontal scroll bar, indicating the position of the currently displayed trend data in the entire trend database.
9. Cursor control button for moving the cursor left or right.
10. Horizontal scroll bar control button for moving the horizontal scroll bar left or right.
11. Vertical scroll bar control button for moving the vertical scroll bar up and down.

## 4.6 Measured Values Screen

Select [Values] to access the measured values screen as shown below.

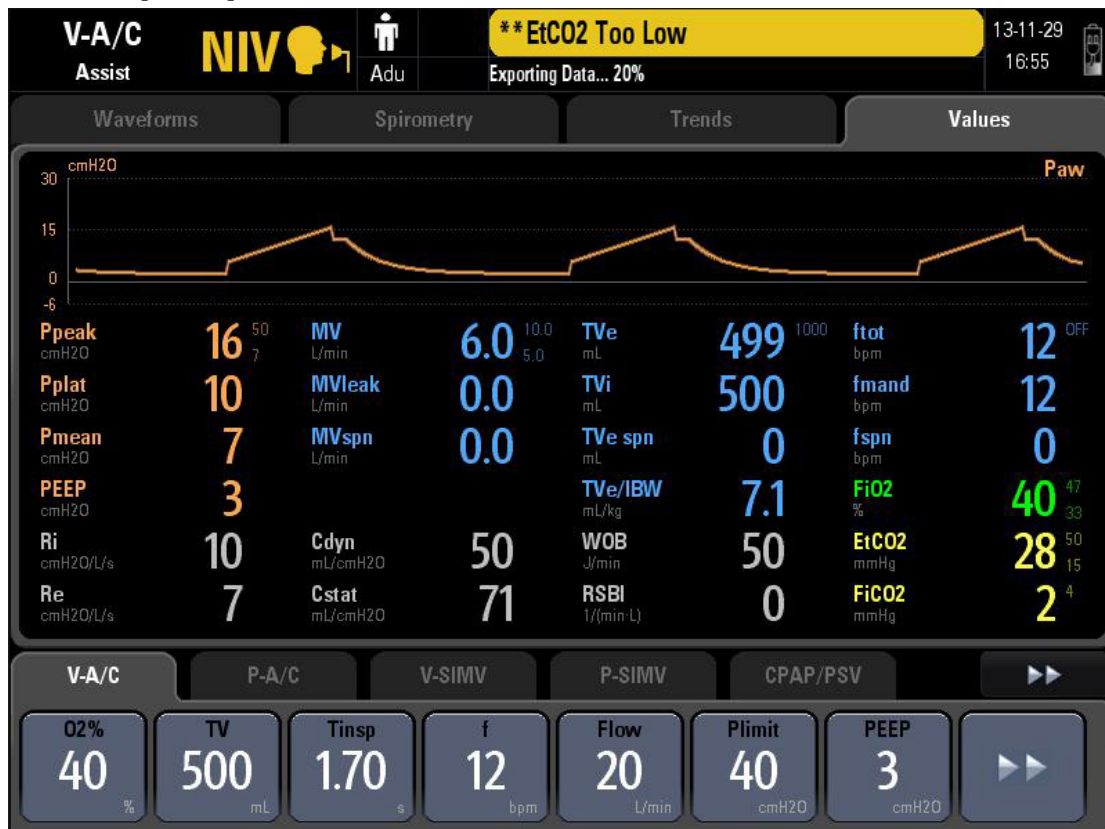

---

## 4.7 Freeze

The freeze function features to pause on-screen waveforms and spirometry loops refreshing in real-time and review short-time patient data so that you can have a close examination of the patient's status within this time period.

### Enter freeze status

In non-standby or non-freeze status, push the Freeze key and [**Freeze Active. Push the Freeze key to unfreeze**] is prompted on the screen. The system enters freeze status. Cursors appear on the waveforms and loops. All displayed waves and loops are frozen, namely, they are not refreshed. The data in the parameter area are refreshed normally. In freeze status, the Save button on the Spirometry Loops screen is disabled, and you cannot save a loop as reference loop but can view an already saved reference loop.

### View frozen waveforms

You can turn the control knob clockwise or counter clockwise to move the cursor to view the frozen waveforms.

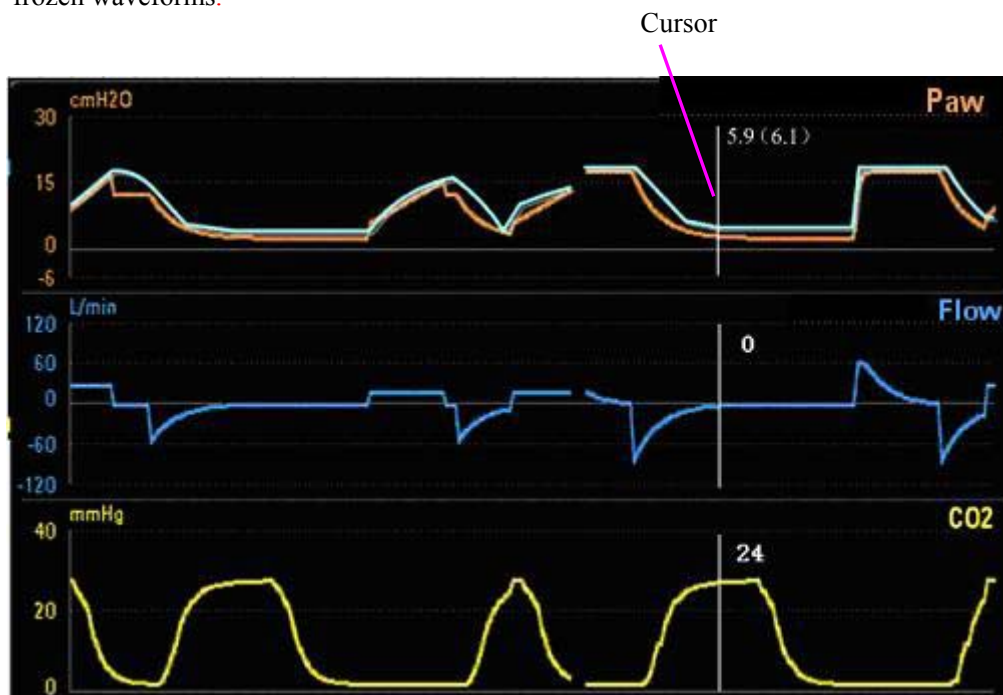

---

## View frozen spirometry loops

You can turn the control knob clockwise or counter clockwise to move the cursor to view the frozen spirometry loops.

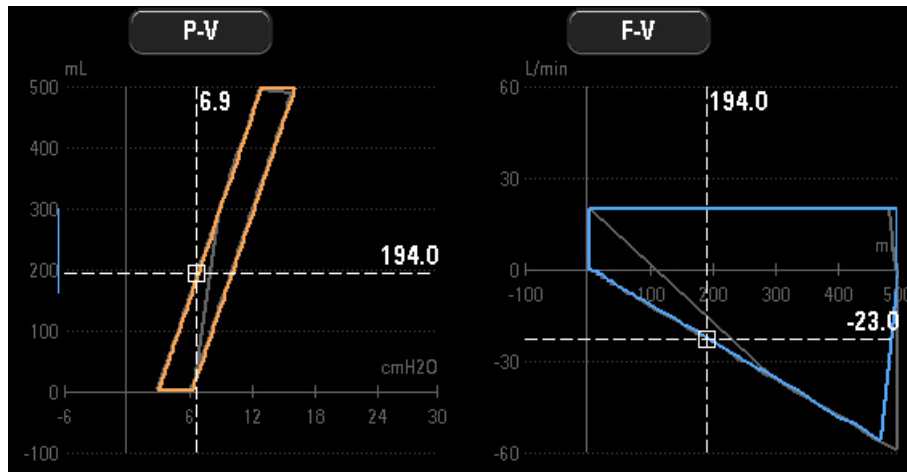

## Exit freeze status

In freeze status, push the Freeze key to exit the freeze status. In freeze status, if no operation is performed on the ventilator for more than three (3) minutes, the system exits freeze status automatically.

---

**FOR YOUR NOTES**

# 5 System Settings

## 5.1 Change Display Settings

### 5.1.1 Waveforms

1. Push the Menu key. Select [**Display**] and then [**Waveforms**].
2. Select the waveforms to be displayed.
3. Select [**Draw Wave**] and toggle between [**Curve**] and [**Fill**].
  - ◆ [**Curve**]: the waveform is displayed as a curved line.
  - ◆ [**Fill**]: the waveform is displayed as a filled area.

### 5.1.2 Spirometry Loops

1. Select [**Spirometry**].
2. Select the loops to be displayed.

### 5.1.3 Measured Values

On the waveforms, spirometry loops, or trends screen, the right side of the screen is divided into three parameter areas which are Parameter Area 1, Parameter Area 2, and Parameter Area 3 from the top down. To change the parameters to be displayed in each parameter area:

1. Press the Menu key. Select [**Display**] and then select [**Values**].
2. Select the parameters to be displayed.



## 5.1.4 Colors

To change the colors of waveforms, waveform related parameters, waveform related spirometry loops, and waveform related alarm limits:

1. Push the Menu key. Select [**Display**] and then [**Color**].
2. Select the desired color. The colors of waveforms, waveform related parameters, waveform related spirometry loops also change. Dark color of the selected color is suggested for the color of waveform related alarm limits.

The following table lists the waveforms, waveform related parameters, waveform related spirometry loops and waveform related alarm limits.

Waveform	Waveform related parameters	Waveform related spirometry loop	Waveform related alarm limits
Paw	Ppeak, Pmean, Pplat, PEEP, NIF, PEEPi, P0.1	P-V loop, F-P loop	Ppeak
Flow	MV, MVleak, MVspn, TVe, TVi, TVspn, ftot, fmand, fspn, Vtrap	F-V loop	MV, TVe, ftot
Volume	/	/	/
/	FiO2	/	FiO2
CO2	EtCO2, FiCO2	/	EtCO2, FiCO2

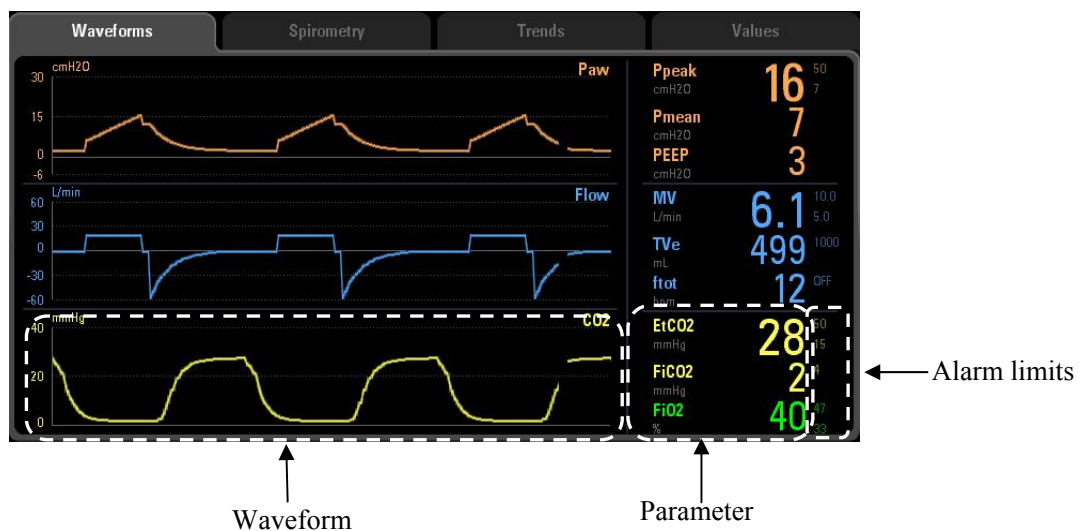

---

## 5.2 Set Date and Time

1. Push the Menu key. Select [**System**] and then [**Time**].
2. Set the date and time.
3. Select [**Date Format**] and toggle between [**YYYY-MM-DD**], [**MM-DD-YYYY**] and [**DD-MM-YYYY**].
4. Select [**Time Format**] and toggle between [**24 h**] and [**12 h**].

## 5.3 Change Language

1. Push the Menu key. Select → [**Maintain**] → [**User**] → enter the required password → [**Setup**] → [**Language**].
2. Select the desired language.
3. Restart the ventilator to activate the selected language.

## 5.4 Adjust Screen Brightness

1. Push the Menu key. Select [**System**] and then [**Ventilator**].
2. Select [**LCD Brightness**] and select the appropriate value (ranging from 1 to 10) for screen brightness. The value 10 is for the brightest and 1 the least bright. If the ventilator is battery powered, you can select a less bright screen to save battery capacity.

## 5.5 Adjust Key Volume

1. Push the Menu key. Select [**System**] and then [**Ventilator**].
2. Select [**Key Volume**] and select the appropriate value (ranging from 0 to 10) for key volume. The value 0 is for audio off and 10 for the loudest.

## 5.6 Set Unit

### 5.6.1 Set Weight Unit

1. Push the Menu key. Select [**System**] and then [**Unit**].
2. Select [**Weight Unit**] and toggle between [**kg**] and [**Ib**].

---

## 5.6.2 Set Paw Unit

1. Push the Menu key. Select [**System**] and then [**Unit**].
2. Select [**Paw Unit**] and toggle between [**cmH2O**], [**hPa**], and [**mbar**].

## 5.6.3 Set CO2 Unit

1. Push the Menu key. Select [**System**] and then [**Unit**].
2. Select [**CO2 Unit**] and toggle between [**mmHg**], [**kPa**], and [%].

## 5.7 Turning on/off O2% Monitoring

1. Push the Menu key. Select [**System**] and then [**Ventilator**].
2. Select [**O2% Monitoring**] and toggle between [**ON**] and [**OFF**]. When [**ON**] is selected, oxygen concentration of patient's inspired gas can be monitored. It needs about 30s after powering on the ventilator till the point that the oxygen concentration monitoring function enters full accuracy mode. You can set [**O2% Monitoring**] to [**OFF**] if oxygen concentration monitoring function accompanying the ventilator is not needed. In this case, [**O2 Monitoring Off**] is prompted on the screen.

## 5.8 Select Tinsp/I:E

1. Push the Menu key. Select [**System**] and then [**Ventilator**].
2. Select [**Tinsp/I:E**] and toggle between [**Tinsp**] and [**I:E**]. Based on your Tinsp/I:E selection, corresponding Tinsp or I/E ventilation setting parameters are adopted for V-A/C, P-A/C and PRVC modes.

## 5.9 Set TV/f Source

1. Push the Menu key. Select [**System**] and then [**Ventilator**].
2. Select [**TV/f Source**] and toggle among [**Height&Gender**], [**IBW**] and [**Patient Type**]. When the ventilator is used on a new patient, the system sets the default TV, f or fapnea values based on the TV/f source setting.

## 5.10 Set Sigh

1. Push the Menu key. Select [**System**] and then [**Ventilator**].
2. Select [**Sigh**] and toggle between [**TV**] and [**Δ int.PEEP**].



---

## 5.11 Set IP Address

If your ventilator needs to upgrade the software, follow these steps to set the IP address:

1. Push the Menu key. Select [**Maintain**] → [**User**] → enter the required password → [**Setup**] → [**IP Address**].
2. Set the IP address. IP address has four step boxes. The setting range of each of the box is 0 to 255.

## 5.12 Manage Configurations

The ventilator provides the following types of configurations:

- Factory configuration, namely, factory preset configuration. There are factory default adult configuration and factory default pediatric configuration based on patient type.
- User configuration. You can change the ventilator's settings based on the actual requirement and save the changed settings as user configuration. There are user adult configuration and user pediatric configuration based on patient type.
- Latest configuration. In actual applications, you may change some settings, which, however, may not be saved as user configuration. The ventilator stores these settings in real time. The stored settings are the latest configuration.

### 5.12.1 Restore the Latest Configuration Automatically

When the ventilator is used on a same patient after powered on, the system adopts the latest configuration automatically.

### 5.12.2 Set Power-on Default Configuration

The ventilator can be set to loading factory default configuration or user default configuration of different patient categories. When the ventilator is used on a new patient, the ventilator loads the set default configuration automatically.

1. Push the Menu key. Select [**Maintain**] → [**User**] → enter the required password → [**Config**].
2. Set [**Select Default Config**].

---

### 5.12.3 Save as User Configuration

You can change the ventilator's settings based on the actual requirement and save the changed settings as user configuration.

1. Push the Menu key. Select [**Maintain**] → [**User**] → enter the required password → [**Config**].
2. If the current patient type is adult, select [**Save as User Adu Config**]. If the current patient type is pediatric, select [**Save as User Ped Config**].

### 5.12.4 Load Configuration Manually

You can load configuration when necessary during the operation of the ventilator.

1. Push the Standby key. The system enters standby status after your confirmation.
2. Push the Menu key. Select [**System**] and then [**Load Config**].
3. Select your desired configuration.

## 5.13 View System Information

### 5.13.1 Version Information

Push the Menu key. Select [**Syst. Info**] and then [**Versions**]. You can view the version information of system software.

### 5.13.2 Configuration Information

Push the Menu key. Select [**Syst. Info.**] and then [**Config Info**]. You can view the configuration information of the ventilator such as ventilation mode.

### 5.13.3 System Check Results

Push the Menu key. Select [**Syst. Info**] and then [**Syst. Check**]. You can view the ventilator system check information, including check items, check results, and check time.

### 5.13.4 Maintenance Information

Push the Menu key. Select [**Syst. Info**] and then [**Maintain**]. You can view total system running time, system startup time, CO<sub>2</sub> last calibration time, O<sub>2</sub> sensor last calibration time, and flow sensor last calibration time.

---

## 5.14 Export

The ventilator's export function means to export some data to USB memory.

### 5.14.1 Export Screen

Screen export means to export the last saved screen capture of the ventilator. The exported file is in bmp format.

To export screenshot,

1. Insert the USB memory to the USB port of the ventilator.
2. Select the desired screen to be exported and then push the Freeze key to capture the screen.
3. Push the Menu key. Select [**Tool**] → [**Export**] → [**Export Screen**]. The system checks the availability of USB memory. If the USB memory is available and has sufficient space, the system exports the last captured screen.

### 5.14.2 Export Data

Data export means to export the patient information, log, trend and other data of the ventilator. The exported file is in html format.

To export data,

1. Insert the USB memory to the USB port of the ventilator.
2. Push the Menu key. Select [**Tool**] → [**Export**] → [**Export Data**]. The system checks the availability of USB memory. If the USB memory is available and has sufficient space, the system exports patient information, log, trend and other data.

---

**FOR YOUR NOTES**

# 6 Start Ventilation

---

---

## 6.1 Turn on the System

1. Plug the power cord into the AC power outlet. Make sure that the AC power LED is lit.
2. Push and hold the  $\odot/\dot{\circ}$  key.
3. The alarm LED flashes yellow and red once in turn and then the speaker and buzzer give a self-test sound.
4. A start-up screen and self-test progress bar appear. Then the standby screen is displayed.

## 6.2 Preoperative Test

### 6.2.1 AC Power and Battery Power Source Switch Test

1. Push the  $\odot/\dot{\circ}$  key to start the ventilator.
2. Remove AC power. Make sure that the AC power LED is extinguished, the battery indicator flashes, and the low level alarm [**Battery in Use**] is triggered.
3. Reconnect AC power and operate the ventilator on AC mains. Make sure that the AC power LED is lit, the battery indicator stops flashing and remains illuminated, and the alarm [**Battery in Use**] disappears.
4. Push the  $\odot/\dot{\circ}$  key again to turn off the ventilator.

### 6.2.2 Pipeline Tests

#### 6.2.2.1 O2 Pipeline Test

1. Connect an O2 pipeline supply.
2. Connect the test splint lung.
3. Push the  $\odot/\dot{\circ}$  key to start the ventilator.
4. Select adult ventilation mode and make the ventilator start ventilation. Make sure that the ventilator ventilates properly.
5. Disconnect the O2 pipeline supply.
6. The high level alarm [**O2 Supply Pressure Low**] is triggered with the decrease in O2 pressure.

---

### 6.2.2.2 Air Pipeline Test

1. Connect an air supply or air compressor gas supply.
2. Connect the test splint lung.
3. Push the  key to start the ventilator.
4. Select adult ventilation mode and make the ventilator start ventilation. Make sure that the ventilator ventilates properly.
5. Disconnect the air pipeline supply or air compressor gas supply.
6. The high level alarm [**Air Supply Pressure Low**] is triggered with the decrease in air pressure.

## 6.3 Power on Self-test

Power on self-tests include:

- CPU self-test
- Memory (RAM and ROM) self test
- Watchdog self-test
- Analog/Digital (A/D) converter self-test
- Temperature sensor self-test
- Buzzer self-test

## 6.4 System Check

---

### **WARNING**

---

- **To ensure optimum performance of the ventilator, re-do system check each time when accessories or components like hose, humidifier, and filter are replaced.**
- 
- 

Push the Standby key. Standby screen appears after your confirmation. The standby screen displays the last system check time. Select [**Syst. Check**]. Connect air and oxygen supplies and block the patient wye as prompted. Select [**Ok**] to start system check item by item.

---

System check items include:

- O2 flow sensor test: test the O2 inspiratory valve and O2 flow sensor;
- Air flow sensor test: test the Air inspiratory valve and Air flow sensor;
- Expiratory flow sensor test;
- Pressure sensor test: test the pressure sensors at the inspiratory and expiratory ports;
- Expiration valve test;
- Safety valve test;
- O2 sensor test;
- Leakage (mL/min);
- Compliance (mL/cmH2O);
- Circuit resistance (cmH2O/L/s).

System check result can be:

- Pass: indicates that check of this item is completed and is passed;
- Fail: indicates that check of this item is completed but is failed;
- Cancel: indicates that check of this item is cancelled;
- No Gas Supply: indicates that O2 or Air supply is not connected when O2 sensor test, O2 or Air flow sensor test is being carried out;
- Monitoring Off: indicates that the sensor monitoring function may not be turned on when O2 sensor test is being carried out.

When system check is being performed, the system prompts [**Running**] on the right side of the current check item. In this case, if you select [**Skip**], the system stops check of this item immediately and displays [**Cancel**]. Check of the next item begins at the same time. If you select [**Stop**], the system stops check of the current item and also check of the remaining items, and displays [**Cancel**].

When checks of all items are completed, if you select [**Retry**], the system starts a new round of check. When [**Exit**] is selected, the system exits check and enters standby screen.

## 6.5 Select Patient

After system check is completed, select [**Exit**] and then select a patient. If [**Same Patient**] is selected, select [**Vent Type**] in the accessed menu and select [**Ok**]. If [**New Patient**] is selected, set [**Patient Type**], [**IBW**], and [**Vent Type**] in the accessed menu, and select [**Ok**].

---

## 6.6 Ventilation Type

The ventilator provides two ventilation types: invasive and non-invasive. Invasive ventilation is the default ventilation type.

### 6.6.1 Invasive Ventilation

Invasive ventilation means to ventilate the patient through manual airway (endotracheal intubation or tracheostomy). In invasive ventilation, all ventilation modes for adult and pediatric patients are enabled. In invasive ventilation, ATRC function can be set.

The calculated leakage is compensated up to 80 % of the set tidal volume in invasive mode.

#### 6.6.1.1 ATRC

ATRC refers to automatic tube resistance compensation function, which the ventilator can adjust the input pressure to keep the pressure of the tube end and pressure set on the ventilator to be the same as possible for endotracheal intubation or tracheotomy intubation of the different tube diameters that the user chooses.

ATRC can be set on the parameter setting interfaces of each mode.

1. Select a ventilation mode, and select [**ATRC**] to enter the ATRC interface.
2. Set the intubation type, tube diameter and the proportion of compensation.
  - ◆ Intubation type: endotracheal intubation or tracheotomy intubation.
  - ◆ Tube diameter: the tube diameter of intubation.
  - ◆ Compensation proportion: the percentage of ATRC.
  - ◆ Compensation of expiration procedure : turn on or off the compensation of expiration procedure.
3. Select [**OK**] to turn on the ATRC function. If ATRC function is turned on, select [**Disable ATRC**] on the ATRC interface to stop the ATRC function of the ventilation procedure immediately.

---

### **WARNING**

- **ATRC function may induce autotriggering. If autotriggering occurs, first check the patient, breathing circuit, and other settings as possible causes before lowering the Compensate setting or disabling ATRC.**
  - **If intubation type and pipe diameter are set incorrectly, it may cause harm to patients. Please set intubation type and pipe diameter correctly.**
-



---

## 6.6.2 NIV (non-invasive ventilation)

NIV, whose full name is non-invasive ventilation, means to ventilate the patient by using a nasal mask or breathing face mask instead of by endotracheal intubation or tracheostomy.

In NIV, all ventilation modes for adult patients and pressure related ventilation modes for pediatric patients are enabled. The disabled ventilation modes in NIV appear grey.

The calculated leakage is compensated up to 200% of the set tidal volume but not more than 2 L maximum in NIV mode.

## 6.6.3 Set Ventilation Type

To set up ventilation type:

1. If the ventilator is not in Standby, push the Standby key and select **[Ok]** from the pop-up dialog box to enter Standby.
2. Select **[Same Patient]** or **[New Patient]** on the standby screen as required.
3. Set **[Vent Type]** to **[Invasive]** or **[NIV]** in the opened menu and then select **[Ok]**.
4. Select **[Start Ventilation]** on the standby screen. If **[NIV]** is selected, the mark for current mode+ mask icon  +NIV is displayed in the upper left corner of the screen, indicating that non-invasive ventilation is set up successfully.

### NOTE

- 
- **NIV can be selected only in Standby.**
-

---

## 6.7 Ventilation Mode

### NOTE

- The ventilator creates negative pressure in the expiratory phase due to patient's active inspiration. There is no limit pressure for negative pressure in the expiratory phase. Instant negative pressure is caused by patient's active inspiration. In the inspiratory phase, high pressure alarm limit is available. When high pressure alarm limit is reached, the ventilator releases pressure immediately. Pressure in the inspiratory phase is generated by the ventilator gas delivery.
  - The P-A/C and P-SIMV are the recommended ventilation modes for use with a closed-suction catheter. And the settings are decided by the operator according to the patient situation.
- 

### 6.7.1 Ventilation Mode and Parameter Setup



1. Ventilation mode setup field

Displays keys for setting ventilation mode. Selecting  displays more keys for setting ventilation mode. The ventilator can be configured with the following ventilation modes: V-A/C, P-A/C, CPAP/PSV, V-SIMV, P-SIMV, PRVC, DuoLevel and APRV. Your machine may have different ventilation modes.

2. Parameter setup quick key field

Displays ventilation setting parameters for the current mode of ventilation. Selecting  displays more ventilation setting parameters. The parameters of ATRC function can be set here. Ventilation parameters vary subject to the ventilation mode.

Follow these steps to set up ventilation modes:

1. In the ventilation mode setup field, select the key to set the desired ventilation mode. The accessed menu displays the ventilation parameters which can be set in the selected ventilation mode.
2. Select the ventilation parameter to be set.
3. Push the control knob and turn it to set the selected parameter to the appropriate value.
4. Push the control knob to confirm the setting.

- 
5. Set other parameters in the same way.
  6. Select [**Ok**] when parameter setup is completed.

Follow these steps to set up ventilation parameters:

1. In the parameter setup quick key field, select the ventilation parameter to be set.
2. Push the control knob and turn it to set the selected parameter to the appropriate value.
3. Push the control knob to confirm the setting.
4. Set other parameters in the same way.

## 6.7.2 Apnea Ventilation

Apnea ventilation is a reserve ventilation mode initiated when the ventilator detects patient apnea in CPAP/PSV, V-SIMV, P-SIMV, DuoLevel, and APRV modes.

Apnea ventilation can exit only when:

- Patient's spontaneous breathing has been detected for two continuous times,
- Ventilation mode has been confirmed again,
- Ventilation mode is swapped,
- The Alarm Reset key is depressed,
- Apnea ventilation is turned off.

Apnea ventilation the ventilator provides is manifested differently subject to the ventilation mode for the purpose of matching the doctor's ventilation strategy to the maximum.

In the SIMV mode, if patient apnea occurs, the ventilator ventilates the patient at the apnea ventilation frequency in place of the previous SIMV frequency (while other parameter settings are kept unchanged). During apnea ventilation, same to the previous SIMV mode, the ventilator allows patient spontaneous breathing or trigger to support ventilation. In the SIMV mode, apnea ventilation can be turned off by setting the apnea ventilation switch. When apnea ventilation is turned off, the message "Apnea Vent Off" is displayed in the prompt message field all the time.

In the CPAP/PSV, DuoLevel or APRV mode, if patient apnea occurs, the ventilator applies pressure control ventilation at the preset apnea pressure and ensures that the actual breathing frequency is not lower than the preset apnea ventilation frequency. During apnea ventilation, the ventilator still allows patient spontaneous breathing or trigger to support ventilation. If patient spontaneous breathing does not occur any longer, the actual breathing frequency is equal to the preset apnea ventilation frequency.

### 6.7.3 IntelliCycle

IntelliCycle intelligent synchronous technology means to adjust Exp% dynamically by adaptive algorithm through extracting and analysing the feature of the waveforms when Exp% is set to Auto in CPAP/PSV, V-SIMV, P-SIMV and DuoLevel modes. According to the lung properties of the patient, it can adjust Exp% to the best value intelligently to improve the synchronization between the patient and the device, make the patient more comfortable during breathing, reduce the time to adjust the settings during treatment, and reduce the workload of medical staffs and ensure the excellent synchronous effect at the same time.

### 6.7.4 V-A/C

V-A/C is volume-assist/control ventilation mode. In V-A/C, fixed tidal volume is delivered to the patient at the inspiratory flow within the inspiration time. The airway pressure varies according to the resistance and compliance of the patient's lungs and thorax. When the airway pressure reaches the preset pressure limit level, it is held at this level. Expiratory phase is switched to and pressure is fully released only when the airway pressure exceeds the pressure alarm high limit.

V-A/C supports synchronous trigger in expiratory phase. Namely, when the ventilator detects patient inspiratory effort, it delivers next mechanical ventilation in advance.

The following figures show typical waveforms in V-A/C mode.

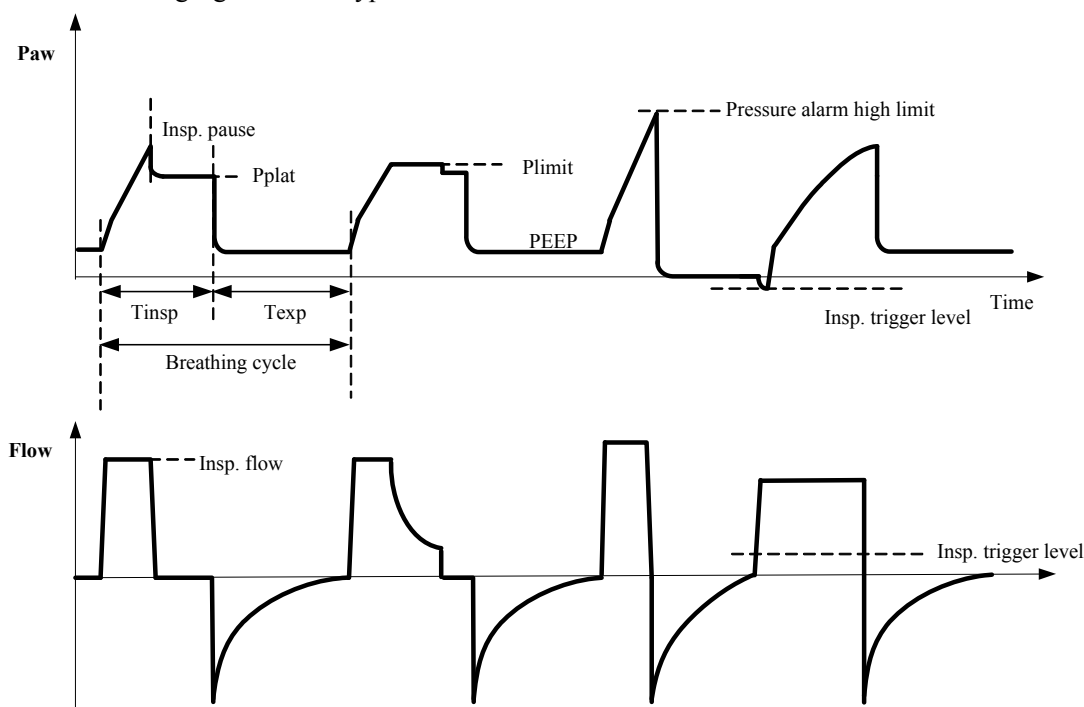

In V-A/C under non-NIV, you need to set the following ventilation parameters:

1. [O<sub>2</sub>%]: Oxygen concentration
2. [TV]: Tidal volume

- 
3. **[Tinsp]** or **[I:E]**: Time of inspiration or ratio between the inspiratory and expiratory time
  4. **[f]**: Breathing frequency
  5. **[Flow]**: Inspiratory flow
  6. **[Plimit]**: Pressure limitation
  7. **[Assist]**: Assisted trigger
  8. **[F-Trig]** or **[P-Trig]**: Inspiration trigger level
  9. **[PEEP]**: Positive end-expiratory pressure
  10. **[ $\Delta$ int.PEEP]** or **[Sigh]**: Intermittent positive end-expiratory pressure
  11. **[ATRC]**: Automatic tube resistance compensation

In V-A/C under NIV, you need to set the following ventilation parameters:

1. **[O2%]**: Oxygen concentration
2. **[TV]**: Tidal volume
3. **[Tinsp]** or **[I:E]**: Time of inspiration or ratio between the inspiratory and expiratory time
4. **[f]**: Breathing frequency
5. **[Flow]**: Inspiratory flow
6. **[Plimit]**: Pressure limitation
7. **[Assist]**: Assisted trigger
8. **[F-Trig]** or **[P-Trig]**: Inspiration trigger level
9. **[PEEP]**: Positive end-expiratory pressure
10. **[ $\Delta$ int.PEEP]** or **[Sigh]**: Intermittent positive end-expiratory pressure

---

## 6.7.5 P-A/C

P-A/C is pressure-assist/control ventilation mode. In P-A/C, the airway pressure rises to the preset inspiratory pressure level within the Time of pressure rising and is held at this level until inspiration time is expired. Then expiration is switched to. When the airway pressure is held at the preset inspiratory pressure level, delivered gas flow changes with the resistance and compliance of the patient's lungs. During the inspiratory phase, when the delivered volume exceeds the tidal volume high alarm limit, the system switches to expiratory phase immediately. During the expiratory phase, synchronous trigger is supported. Specifically, next mechanical ventilation can be delivered in advance when patient inspiratory effort is detected.

The following figures show typical waveforms in P-A/C mode.

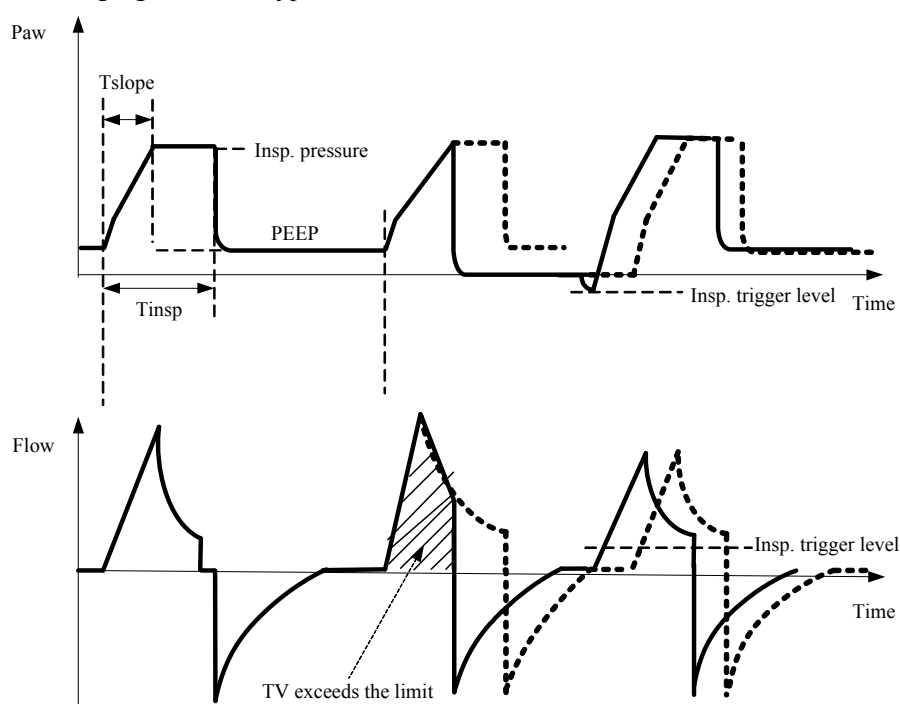

In P-A/C under non-NIV, you need to set the following ventilation parameters:

1. **[O2%]:** Oxygen concentration
2. **[Pinsp]:** Pressure control level of inspiration
3. **[Tinsp]** or **[I:E]:** Time of inspiration or ratio between the inspiratory and expiratory time
4. **[f]:** Breathing frequency
5. **[Tslope]:** Time of pressure rising
6. **[PEEP]:** Positive end-expiratory pressure
7. **[Assist]:** Assisted trigger
8. **[F-Trig]** or **[P-Trig]:** Inspiration trigger level
9. **[ATRC]:** Automatic tube resistance compensation

In P-A/C under NIV, you need to set the following ventilation parameters:

1. **[O2%]:** Oxygen concentration
2. **[Pinsp]:** Pressure control level of inspiration
3. **[Tinsp]** or **[I:E]:** Time of inspiration or ratio between the inspiratory and expiratory time
4. **[f]:** Breathing frequency
5. **[Tslope]:** Time of pressure rising
6. **[PEEP]:** Positive end-expiratory pressure
7. **[Assist]:** Assisted trigger
8. **[F-Trig]** or **[P-Trig]:** Inspiration trigger level

### 6.7.6 CPAP/PSV

PSV, pressure support ventilation, is a pressure mode. The system delivers a PSV when it detects that patient inspiratory effort reaches the preset inspiration trigger level. Time of pressure rising and pressure support level are set by the user. At the beginning of inspiratory phase, patient airway pressure rises to the preset pressure level within the preset Time of pressure rising and is held at this pressure level until patient inspiratory flow is detected to reach the expiration trigger level. In PSV, when the airway pressure is held at the preset pressure level, delivered gas flow changes with the resistance and compliance of the patient's lungs.

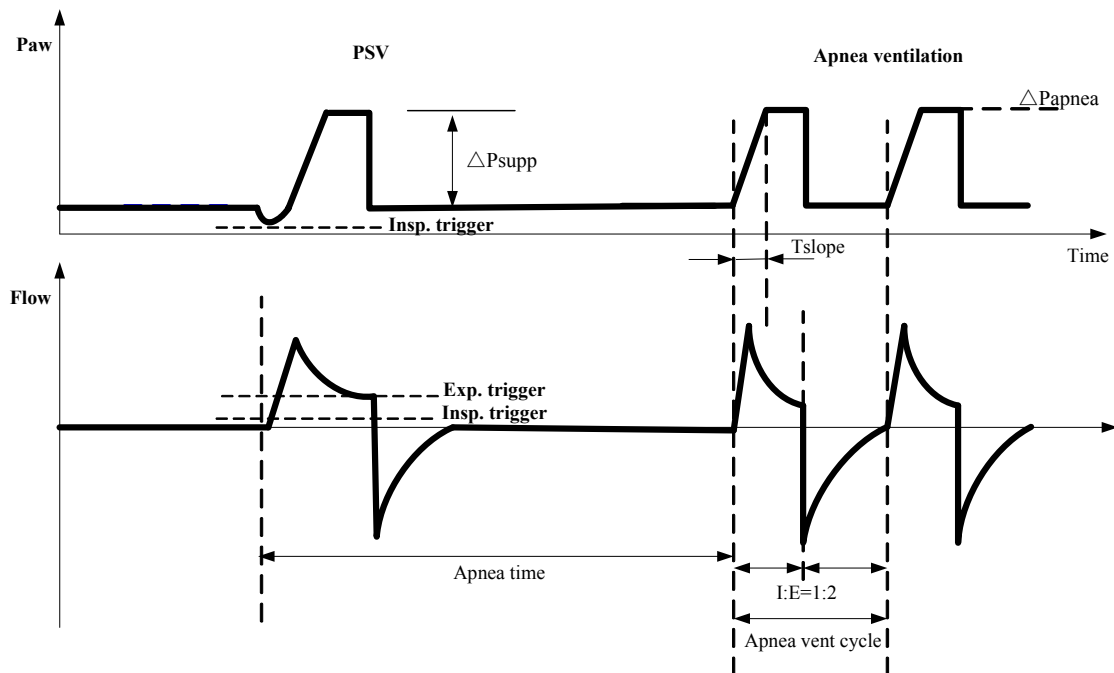

In CPAP (continuous positive airway pressure ventilation), the airway pressure is held at the user-set positive pressure level throughout the ventilation cycle. The patient breathes spontaneously and determines his own breathing frequency, tidal volume, and breath time. The system starts apnea ventilation when detecting that the period of time when patient does not perform continuous spontaneous breathing exceeds the preset apnea time.

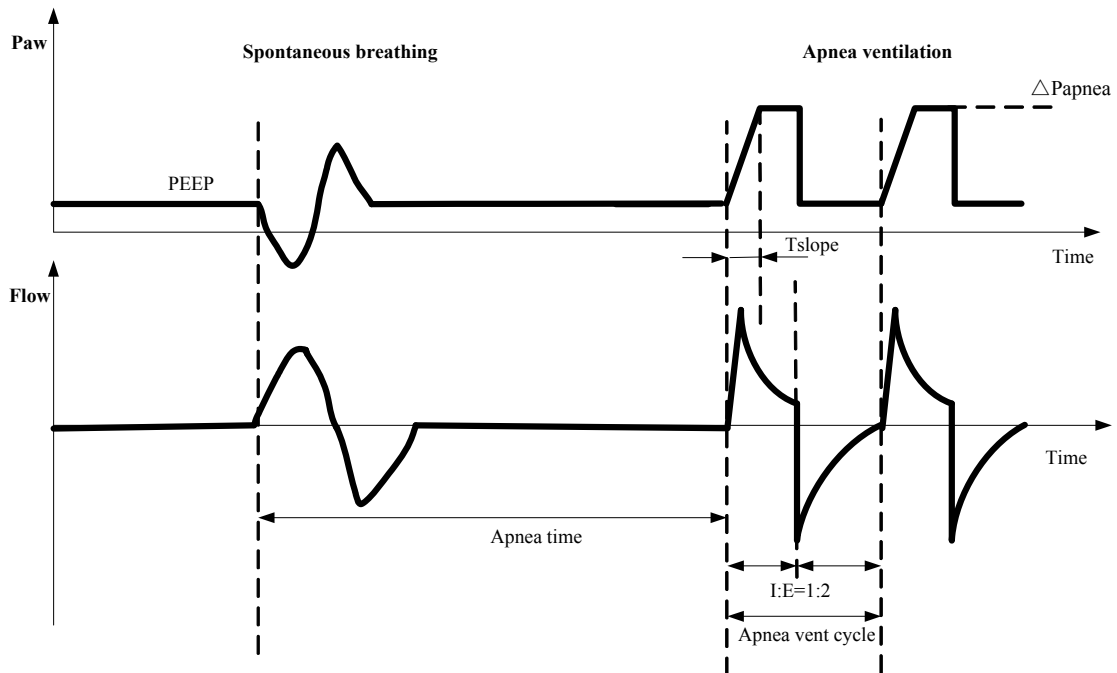

In CPAP/PSV under non-NIV, you need to set the following ventilation parameters:

1. **[O2%]:** Oxygen concentration
2. **[Tslope]:** Time of pressure rising
3. **[ $\Delta$ Psupp]:** Pressure support level
4. **[PEEP]:** Positive end-expiratory pressure
5. **[Exp%]:** Expiration trigger level
6. **[ $\Delta$ Papnea]:** Pressure of apnea ventilation
7. **[fapnea]:** Frequency of apnea ventilation
8. **[F-Trig] or [P-Trig]:** Inspiration trigger level
9. **[ATRC]:** Automatic tube resistance compensation

In CPAP/PSV under NIV, you need to set the following ventilation parameters:

1. **[O2%]:** Oxygen concentration
2. **[Tslope]:** Time of pressure rising
3. **[ $\Delta$ Psupp]:** Pressure support level
4. **[PEEP]:** Positive end-expiratory pressure



5. [Exp%]: Expiration trigger level
6. [ $\Delta P_{apnea}$ ]: Pressure of apnea ventilation
7. [fapnea]: Frequency of apnea ventilation
8. [Tinsp]: Inspiration time
9. [F-Trig] or [P-Trig]: Inspiration trigger level

### 6.7.7 V-SIMV and P-SIMV

SIMV is designed to guarantee minimum ventilation frequency. Volume control ventilation or pressure control ventilation in SIMV mode is delivered within the trigger window and is delivered automatically at the end of the trigger window if not triggered within the trigger window. Outside the trigger window, spontaneous breathing is supported.

The following figures show typical waveforms in V-SIMV+PSV and P-SIMV+PSV modes.

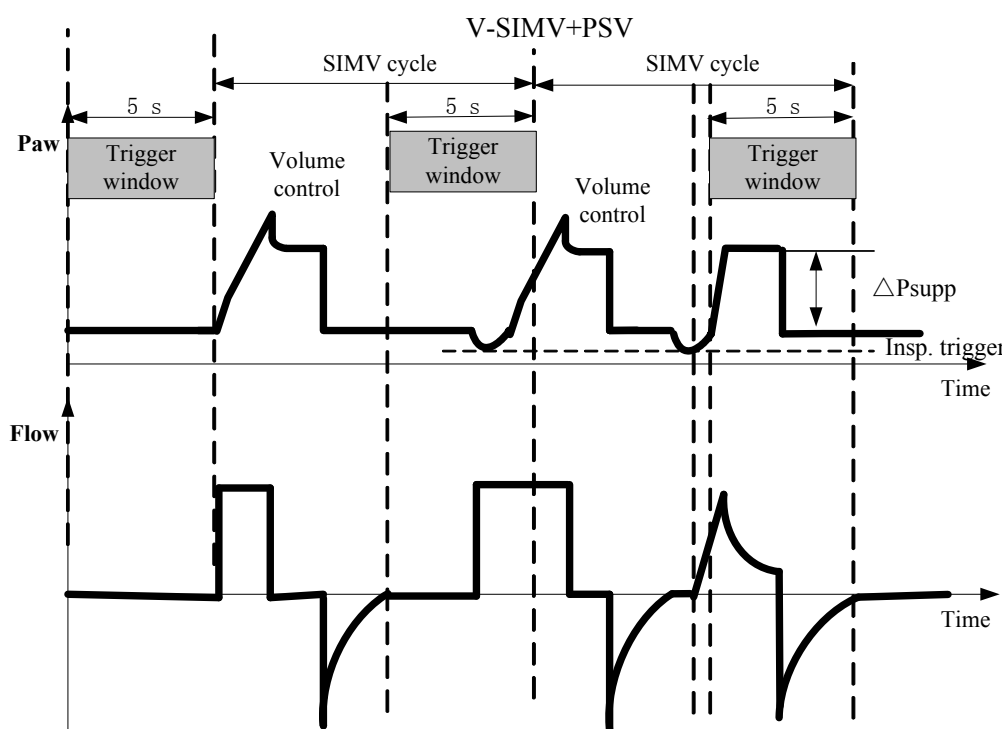

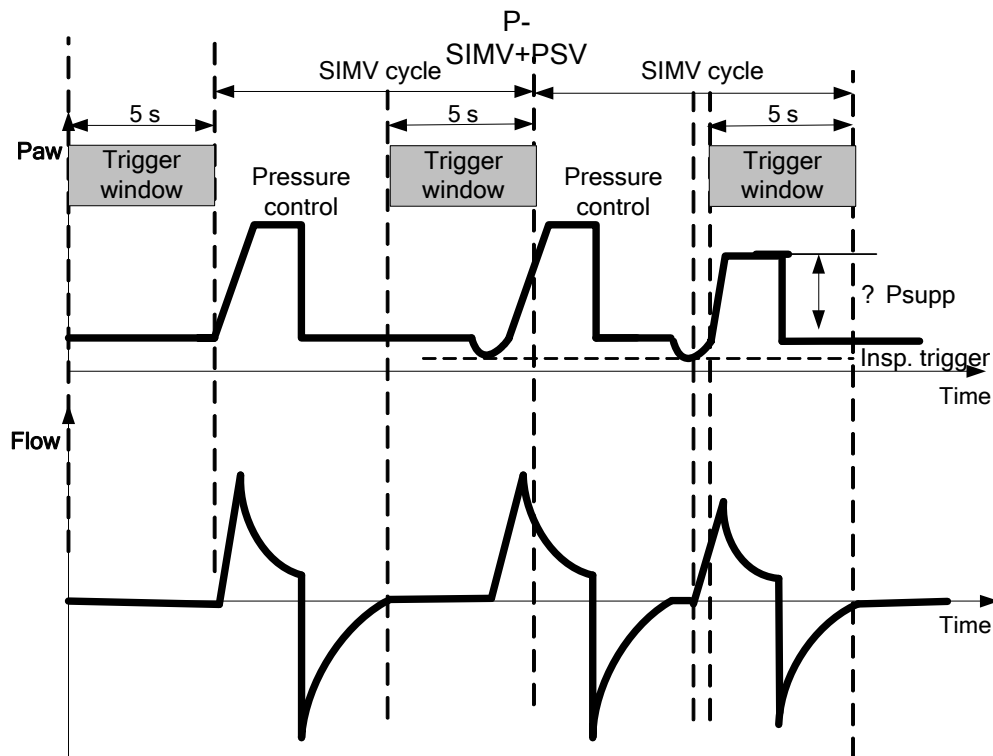

In V-SIMV under non-NIV, you need to set the following ventilation parameters:

1. **[O2%]:** Oxygen concentration
2. **[TV]:** Tidal volume
3. **[Tinsp]:** Time of inspiration
4. **[fSIMV]:** Frequency of SIMV
5. **[Flow]:** Inspiratory flow
6. **[Plimit]:** Pressure limitation
7. **[PEEP]:** Positive end-expiratory pressure
8. **[Exp%]:** Expiration trigger level
9. **[ $\Delta$ Psupp]:** Pressure support level
10. **[Tslope]:** Time of pressure rising
11. **[F-Trig] or [P-Trig]:** Inspiration trigger level
12. **[fapnea]:** Frequency of apnea ventilation
13. **[Apnea Vent]:** Apnea ventilation switch
14. **[ATRC]:** Automatic tube resistance compensation

In V-SIMV under non-NIV, you need to set the following ventilation parameters:

1. **[O2%]:** Oxygen concentration
2. **[TV]:** Tidal volume
3. **[Tinsp]:** Time of inspiration

- 
4. [**fSIMV**]: Frequency of SIMV
  5. [**Flow**]: Inspiratory flow
  6. [**Plimit**]: Pressure limitation
  7. [**PEEP**]: Positive end-expiratory pressure
  8. [**Exp%**]: Expiration trigger level
  9. [ **$\Delta$ Psupp**]: Pressure support level
  10. [**Tslope**]: Time of pressure rising
  11. [**F-Trig**] or [**P-Trig**]: Inspiration trigger level
  12. [**fapnea**]: Frequency of apnea ventilation
  13. [**Apnea Vent**]: Apnea ventilation switch

In P-SIMV under non-NIV, you need to set the following ventilation parameters:

1. [**O2%**]: Oxygen concentration
2. [**Pinsp**]: Pressure control level of inspiration
3. [**Tinsp**]: Time of inspiration
4. [**fSIMV**]: Frequency of SIMV
5. [**Tslope**]: Time of pressure rising
6. [**PEEP**]: Positive end-expiratory pressure
7. [**Exp%**]: Expiration trigger level
8. [ **$\Delta$ Psupp**]: Pressure support level
9. [**fapnea**]: Frequency of apnea ventilation
10. [**F-Trig**] or [**P-Trig**]: Inspiration trigger level
11. [**Apnea Vent**]: Apnea ventilation switch
12. [**ATRC**]: Automatic tube resistance compensation

In P-SIMV under NIV, you need to set the following ventilation parameters:

1. [**O2%**]: Oxygen concentration
2. [**Pinsp**]: Pressure control level of inspiration
3. [**Tinsp**]: Time of inspiration
4. [**fSIMV**]: Frequency of SIMV
5. [**Tslope**]: Time of pressure rising
6. [**PEEP**]: Positive end-expiratory pressure
7. [**Exp%**]: Expiration trigger level

8. [ $\Delta P_{supp}$ ]: Pressure support level
9. [ $f_{apnea}$ ]: Frequency of apnea ventilation
10. [ $F-Trig$ ] or [ $P-Trig$ ]: Inspiration trigger level
11. [ $Apnea Vent$ ]: Apnea ventilation switch

## 6.7.8 PRVC

PRVC implements volume control by way of pressure control ventilation. In PRVC, a relatively low pressure level is held as much as possible during the inspiratory phase and the gas volume delivered is guaranteed to be equal to the set tidal volume.  $P_{insp}$  will vary according to the tidal volume setting and resistance and compliance of the patient's lungs. The ventilator adjusts  $P_{insp}$  each time at a maximum increment of 3 cmH<sub>2</sub>O and the maximum pressure does not exceed the pressure high alarm limit -5 cmH<sub>2</sub>O.

The first PRVC delivered is experimental ventilation mode for the purpose of calculating compliance and resistance of the system and patient's lungs based on which pressure level is acquired. This pressure level will then be used for tidal volume control in the subsequent ventilation cycles.

The following figures show typical waveforms in PRVC mode.

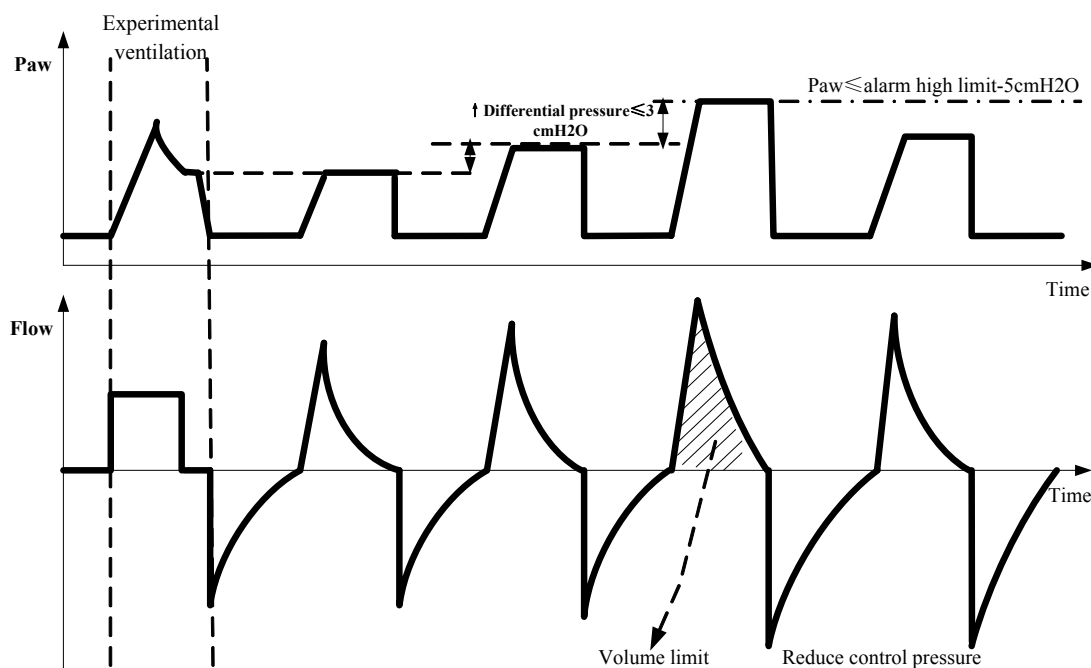

In PRVC under non-NIV, you need to set the following ventilation parameters:

1. [ $O_2\%$ ]: Oxygen concentration
2. [ $TV$ ]: Tidal volume
3. [ $T_{insp}$ ] or [ $I:E$ ]: Time of inspiration or ratio between the inspiratory and expiratory time

- 
4. **[f]**: Breathing frequency
  5. **[Tslope]**: Time of pressure rising
  6. **[PEEP]**: Positive end-expiratory pressure
  7. **[Assist]**: Assisted trigger
  8. **[F-Trig]** or **[P-Trig]**: Inspiration trigger level
  9. **[ATRC]**: Automatic tube resistance compensation

In PRVC under NIV, you need to set the following ventilation parameters:

1. **[O2%]**: Oxygen concentration
2. **[TV]**: Tidal volume
3. **[Tinsp]** or **[I:E]**: Time of inspiration or ratio between the inspiratory and expiratory time
4. **[f]**: Breathing frequency
5. **[Tslope]**: Time of pressure rising
6. **[PEEP]**: Positive end-expiratory pressure
7. **[Assist]**: Assisted trigger
8. **[F-Trig]** or **[P-Trig]**: Inspiration trigger level

---

## 6.7.9 DuoLevel

DuoLevel is double level positive airway pressure ventilation. In DuoLevel, the ventilator delivers positive airway pressure at two pressure levels alternatively during mechanical ventilation or spontaneous breathing. The patient can breathe spontaneously at either pressure level. During the low pressure phase, pressure support can be set. Trigger window is available during both high and low pressure phases. The trigger window during the low pressure phase is the later 5 seconds of low pressure time (Tlow) while the trigger window during the high pressure phase is the later 1/4 of high pressure time (Thigh). Within the trigger window of low pressure phase, inspiratory trigger transforms to high pressure gas delivery. Within the trigger window of high pressure phase, expiratory trigger transforms to low pressure gas delivery.

The following figure shows typical waveform in DuoLevel mode.

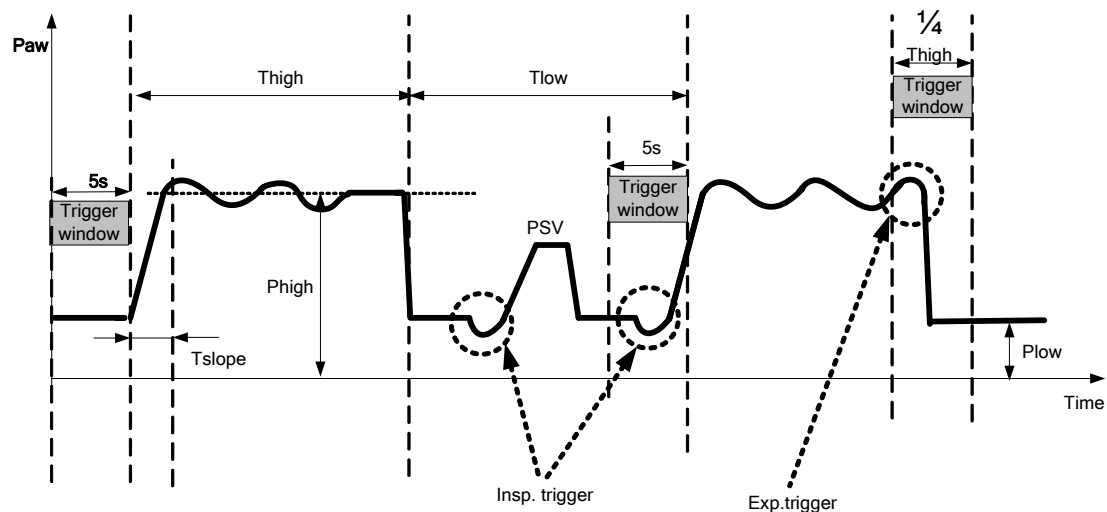

In DuoLevel under non-NIV, you need to set the following ventilation parameters:

1. [O2%]: Oxygen concentration
2. [Phigh]: High pressure
3. [Thigh]: Time of high pressure
4. [Plow]: Low pressure
5. [Tlow]: Time of low pressure
6. [Tslope]: Time of pressure rising
7. [Exp%]: Expiration trigger level
8. [ $\Delta$ Psupp]: Pressure support level
9. [ $\Delta$ Papnea]: Pressure of apnea ventilation
10. [fapnea]: Frequency of apnea ventilation
11. [F-Trig] or [P-Trig]: Inspiration trigger level
12. [ATRC]: Automatic tube resistance compensation

---

In DuoLevel under NIV, you need to set the following ventilation parameters:

1. **[O2%]:** Oxygen concentration
2. **[Phigh]:** High pressure
3. **[Thigh]:** Time of high pressure
4. **[Plow]:** Low pressure
5. **[Tlow]:** Time of low pressure
6. **[Tslope]:** Time of pressure rising
7. **[Exp%]:** Expiration trigger level
8. **[ $\Delta$ Psupp]:** Pressure support level
9. **[ $\Delta$ Papnea]:** Pressure of apnea ventilation
10. **[fapnea]:** Frequency of apnea ventilation
11. **[F-Trig] or [P-Trig]:** Inspiration trigger level

### 6.7.10 APRV

APRV is airway pressure release ventilation. It can be seen as periodical, short period airway pressure release in CPAP mode.

The following figure shows typical waveform in APRV.

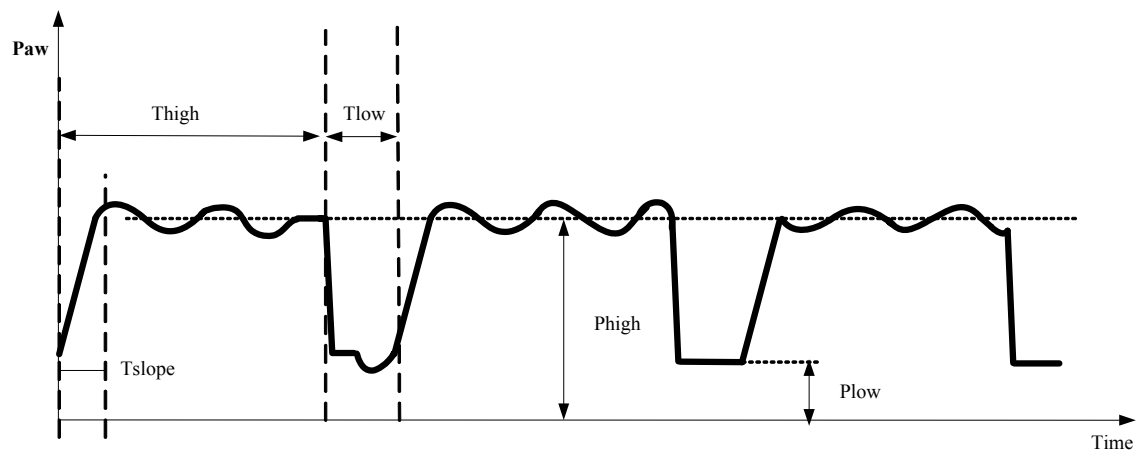

In APRV under non-NIV, you need to set the following ventilation parameters:

1. **[O2%]:** Oxygen concentration
2. **[Phigh]:** High pressure
3. **[Thigh]:** Time of high pressure
4. **[Plow]:** Low pressure
5. **[Tlow]:** Time of low pressure

- 
6. [Tslope]: Time of pressure rising
  7. [ΔPapnea]: Pressure of apnea ventilation
  8. [fapnea]: Frequency of apnea ventilation
  9. [ATRC]: Automatic tube resistance compensation

In APRV under NIV, you need to set the following ventilation parameters:

1. [O2%]: Oxygen concentration
2. [Phigh]: High pressure
3. [Thigh]: Time of high pressure
4. [Plow]: Low pressure
5. [Tlow]: Time of low pressure
6. [Tslope]: Time of pressure rising
7. [ΔPapnea]: Pressure of apnea ventilation
8. [fapnea]: Frequency of apnea ventilation

## 6.8 Change Alarm Limits

You can change the alarm limits for Paw, MV, ftot and TVe by pushing the Alarm Setup key and selecting [Alarm Limits]. You can change the alarm limits for EtCO<sub>2</sub> if your ventilator is configured with CO<sub>2</sub> module. You can also change alarm volume and apnea time. For details, refer to *9 Alarms*.

## 6.9 Ventilate the Patient

---

### WARNING

---

- Before use on the patient, check that the oxygen concentration in the delivered gas is consistent with the set value.
- 

Select [Start Ventilation] when in Standby and the system begins to ventilate the patient according to your settings.



---

## 6.10 Ventilation Parameters Monitoring

---

### WARNING

- As required by the relevant rules and regulations, oxygen concentration should be monitored when the equipment is used on the patient. If your ventilator is not configured with such monitoring function or this function is turned off, use a monitor which complies with the relevant international rules and regulations for oxygen concentration monitoring.
- 

### NOTE

- All the parameter values are calculated based on the real-time flow and pressure waveforms data. For real-time flow and pressure data, five-point moving average filter (FIR low pass filter) is adopted at original sampling rate of 250 Hz with about 24 Hz of cutoff frequency (3 db) and 10 ms of delay.
  - The conditions to which the tidal volume and minute volume the ventilator displays correspond are temperature, ambient pressure, and saturated water vapor status.
- 

Setting parameter	Description
TV	The gas volume the patient inspires or expires each time during resting breathing.
O2%	The volume percentage of oxygen in the mixed gas delivered to the patient.
Flow	The gas delivered flow that the ventilator will use during the inspiratory phase.
I:E	The ratio between the inspiratory and expiratory time.
PEEP	Positive end-expiratory pressure.
Phigh	Available only in DuoLevel and APRV modes. Phigh is the high pressure level at which the patient can spontaneously breathe and is an absolute value.
Pinsp	Inspiratory pressure in pressure control mode. It is an absolute value.
$\Delta$ Papnea	Available only in CPAP/PSV, DuoLevel and APRV modes. $\Delta$ Papnea is inspiratory pressure in apnea ventilation mode and is relative to PEEP or P <sub>low</sub> .
Plimit	The pressure limit level at which the airway pressure is held during the inspiratory phase until the start of expiratory phase.
P <sub>low</sub>	Available only in DuoLevel and APRV modes. P <sub>low</sub> is the low pressure level at which the patient can breathe spontaneously.

$\Delta P_{\text{supp}}$	The pressure support level in pressure support mode and is relative to PEEP or P <sub>low</sub> .
T <sub>slope</sub>	Controls pressure rise slope in pressure mode.
f	The number of mechanically controlled breaths delivered to the patient in one minute.
f <sub>apnea</sub>	Breathing frequency set in apnea ventilation mode.
f <sub>SIMV</sub>	Breathing frequency set in SIMV mode.
T <sub>high</sub>	Available only in DuoLevel and APRV modes. T <sub>high</sub> is the time that the ventilator will hold the high pressure level.
T <sub>low</sub>	Available only in DuoLevel and APRV modes T <sub>low</sub> is the time that the ventilator will hold the low pressure level.
T <sub>insp</sub>	Time of inspiration in one breathing cycle.
F-Trig/P-Trig	Pressure trigger and flow trigger included. When the trigger level is detected, the ventilator starts to enter the inspiratory phase. When F-Trig is active, at the late stage of exhalation the ventilator delivers a base flow from the inspiratory limb to the expiratory limb. The base flow is essential for flow trigger. The ventilator adjusts base flow from 2 to 20 L/min automatically to maintain PEEP and establish baseline for patient triggering.
$\Delta \text{int.PEEP}$	Available only in V-A/C mode. It indicates the positive end expiratory pressure added in the sigh cycle, and is relative to PEEP.
Exp%	Inspiratory termination level. The ventilator is switched to the expiratory phase when the inspiratory flow drops to peak flow*Exp%. When the value of Exp% is set to Auto, the IntelliCycle function is turned on.
Assist	This parameter is available in V-A/C, P-A/C and PRVC modes to turn on or turn off the assisted trigger function. When this function is turned on, the patient is allowed to trigger mechanical ventilation at the end of expiration.
ATRC	This parameter is available in all the ventilation modes except NIV to set the ATRC function.



<b>Monitored parameter</b>	<b>Description</b>
P <sub>peak</sub>	The maximum pressure value in one breathing cycle.
P <sub>plat</sub>	The airway pressure during inspiratory pause.
P <sub>mean</sub>	The mean pressure value in one breathing cycle.
PEEP	Positive end-expiratory pressure.
T <sub>Vi</sub>	The inspired tidal volume in one cycle.

TVe	The expired tidal volume in one cycle.
TVe/IBW	The expired tidal volume in one cycle per IBW.
TVe spn	The spontaneous expired tidal volume in one cycle.
MV	The accumulated expired tidal volume in one minute.
MVspn	The accumulated spontaneous expired tidal volume in one minute.
MVleak	The accumulated leakage (inspiratory volume minus expiratory volume) in one minute.
ftot	The accumulated number of breaths in one minute.
fmand	The accumulated number of mandatory breaths in one minute.
fspn	The accumulated number of spontaneous breaths in one minute.
Ri	The airway resistance during inspiration.
Re	The airway resistance during expiration.
Cstat	The static compliance.
Cdyn	The dynamic compliance.
RSBI	Rapid shallow breath index that is defined as fspn/TVespn.
WOB	Work of breath.
NIF	Negative inspiratory force.
P0.1	The pressure drop in the first 100 ms when the patient starts spontaneous breathing.
PEEPi	Intrinsic PEEP(The PEEPi value displayed has already included PEEP value and is the actual airway pressure).
Vtrap	The volume of trap gas in the lungs produced by intrinsic PEEP.
FiO2	The percentage of oxygen in the patient's inspired gas.
EtCO2	The concentration of CO2 measured at the end of expiration.
FiCO2	The minimum CO2 concentration measured during inspiration.

## 6.11 Enter Standby

Push the Standby key. Standby screen appears after your confirmation.

## 6.12 Turn the System off

Push the  key to turn the system off when in Standby. In non-Standby, push the  key and the system prompts [**Please enter Standby mode to shut down the system.**]. Select [**Ok**] to close the dialog. The system is still in non- Standby.

---

**FOR YOUR NOTES**

# 7 CO<sub>2</sub> Monitoring

---

---

## 7.1 Introduction

CO<sub>2</sub> monitoring is a continuous, non-invasive technique for determining the concentration of CO<sub>2</sub> in the patient's airway by measuring the absorption of infrared (IR) light of specific wavelengths. The CO<sub>2</sub> has its own absorption characteristic and the amount of light passing the gas probe depends on the concentration of the measured CO<sub>2</sub>. When a specific band of IR light is passed through respiratory gas samples, some of IR light will be absorbed by the CO<sub>2</sub> molecules. The amount of IR light transmitted after it has been passed through the respiratory gas sample is measured with a photodetector. From the amount of IR light measured, the concentration of CO<sub>2</sub> is calculated. End tidal CO<sub>2</sub> concentration reading is using the highest values respectively of the temporal CO<sub>2</sub>-curve.

The measurement provides:

1. CO<sub>2</sub> waveform;
2. End-tidal CO<sub>2</sub> (EtCO<sub>2</sub>) value: the CO<sub>2</sub> value measured at the end of the expiration phase;
3. Fraction of inspired CO<sub>2</sub> (FiCO<sub>2</sub>): the CO<sub>2</sub> value measured during inspiration.

The rated respiration rate range of etCO<sub>2</sub> module is 0 to 120 bpm, and the data sample rate is 50 Hz. The method used to determine the rated respiration rate range: Utilize a valve to permit switching between the two sampling gases at different frequencies (simulating the range of specified breath rates). Record the etCO<sub>2</sub> value presented for each frequency. From a diagram of end-tidal value over frequency, the frequency at which the gas analyzer is no longer able to resolve etCO<sub>2</sub> according to specification is identified.

---

## NOTE

---

- As required by the relevant rules and regulations, carbon dioxide concentration should be monitored when the equipment is used on the patient. If your ventilator is not configured with such monitoring function, use a monitor which complies with the relevant international rules and regulations for carbon dioxide concentration monitoring.
- 

## 7.2 Prepare to Measure CO<sub>2</sub>

1. Attach the water trap to the water trap fixer and then connect the CO<sub>2</sub> components as shown below.

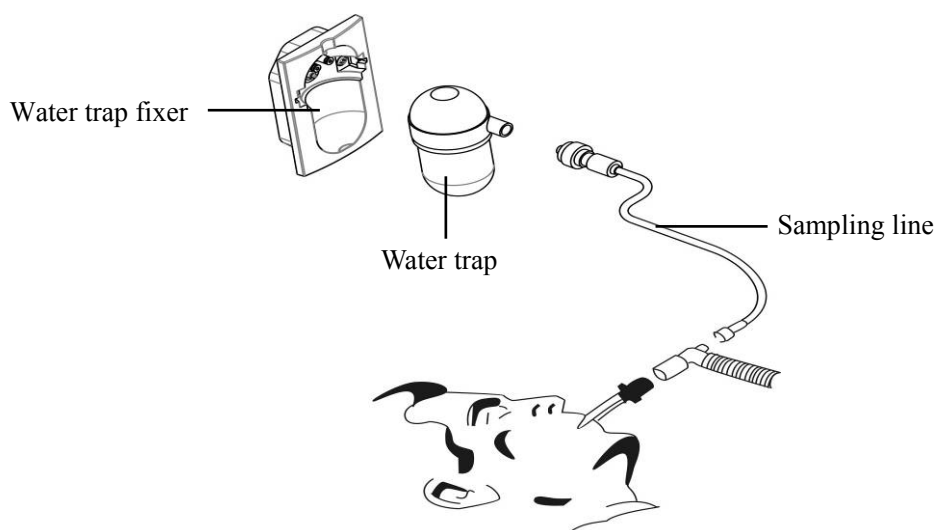

2. By default, the CO<sub>2</sub> module is in measure mode. When the CO<sub>2</sub> module is connected, the [CO<sub>2</sub> Startup] message is displayed on the screen.
3. After start-up is finished, the [CO<sub>2</sub> Warmup] message is displayed. The CO<sub>2</sub> module is in ISO accuracy mode. If you perform CO<sub>2</sub> measurements during warm-up, the measurement accuracy may be compromised.
4. After warm-up is finished, the CO<sub>2</sub> module enters full accuracy mode.

It needs about 2 minutes after powering on the ventilator till the point that the CO<sub>2</sub> module enters full accuracy mode.

---

## NOTE

---

- To extend the lifetime of the water trap and CO2 module, disconnect the water trap and set the working mode of the module to standby when CO2 monitoring is not required.
  - The CO2 measurement can be used, with specified accessories, with intubated and non-intubated adult, pediatric. With patients, a sample of the respiratory gas is drawn from the patient's breathing circuit through an airway adapter and a gas sampling line.
- 

---

## CAUTION

---

- The water trap collects water drops condensed in the sampling line and therefore prevents them from entering the module. If the collected water reaches a certain amount, you should drain it to avoid blocking the airway. Dispose of accumulated fluids in accordance with the hospital policy or your local regulations.
  - The water trap has a filter preventing bacterium, vapor and patient secretions from entering the module. After a long-term use, dust or other substances may compromise the performance of the filter or even block the airway. In this case, replace the water trap. Replacing the water trap once a month is recommended. Or, replace the water trap when it is detected leaky, damaged or contaminated.
- 

## 7.3 Make CO2 Settings

Connect the CO2 module to the ventilator. Push the Menu key. Select [System] and then [CO2]. You can make CO2 settings as described below.

---

### 7.3.1 Set Working Mode

The default working mode of the CO2 module is **[Measure]** when the ventilator is turned on for the first time. If the current CO2 module is Standby, push the Menu key. Select **[System]** and then **[CO2]**. Set **[Working Mode]** to **[Measure]** to start the CO2 module. When the ventilator restarts, the CO2 module automatically continues with the previously selected working mode.

When Standby, the working components of the CO2 module such as gas pump and infrared light source are automatically turned off to extend the service life of the module.

### 7.3.2 Set Pump Rate

You can set patient **[Pump Rate]** to either **[100 mL/min]** or **[70 mL/min]**.

The pump rate tolerance: 15% or 15 ml/min, whichever is greater.

During normal use (37 °C, 100% RH), the maximum emptying interval during normal use (sample gas 37 °C, 100% RH) for adult and pediatric use: 45 h@70 ml/min, 21 h@150 ml/min.

---

#### **WARNING**

---

- **Take the patient's actual bearing capability into consideration and select the appropriate pump rate when setting the pump rate.**
- 

### 7.3.3 Set Unit

1. Push the Menu key. Select **[System]** and then **[Unit]**.
2. Select **[CO2 Unit]** and toggle between **[mmHg]**, **[kPa]**, and **[%]**.



---

### 7.3.4 Set Humidity Compensation

The CO<sub>2</sub> module is configured to compensate CO<sub>2</sub> readings for either Body Temperature and Pressure, Saturated Gas (BTPS), to account for humidity in the patient's breath, or Ambient Temperature and Pressure, Dry Gas (ATPD).

1. ATPD:  $P_{CO_2}(mmHg) = CO_2(vol\%) \times P_{amb} / 100$

2. BTPS:  $P_{CO_2}(mmHg) = CO_2(vol\%) \times (P_{amb} - 47) / 100$

where,  $P_{CO_2}$  = partial pressure,  $vol\%$  = CO<sub>2</sub> concentration,  $P_{amb}$  = ambient pressure, and unit is mmHg.

For CO<sub>2</sub> module, humidity compensation is switched on or off based on the actual situations.

1. Push the Menu key. Select [**System**] and then [**CO2**].
2. Set [**Humidity Comp**] to [**ON**] or [**OFF**] in either BTPS or ATPD.

### 7.3.5 Restore Defaults

Push the Menu key. Select [**System**] and then [**CO2**]. Select [**Defaults**] to restore all menu options to the factory default configurations.

### 7.3.6 Set CO2 Waveform

Refer to *5.1.1 Waveforms* to set CO<sub>2</sub> waveform..

## 7.4 Measurement Limitations

Measurement accuracy may be compromised due to:

- Leakage or internal leakage of the sample gas
- Mechanical shock
- Cyclic pressure which is greater than 10 kPa (100 cmH<sub>2</sub>O)
- Other interference source (if available)

Measurement accuracy may be affected by the breath rate and I/E ratio as follow:

etCO<sub>2</sub> is within specification for breath rate  $\leq 60$  bpm and I/E ratio  $\leq 1:1$ ;

etCO<sub>2</sub> is within specification for breath rate  $\leq 30$  bpm and I/E ratio  $\leq 2:1$ .

Measurement accuracy is unspecified for breath rate larger than 60 bpm.

---

## 7.5 Troubleshooting

When the sampling system of the CO2 module works incorrectly, check if the sampling line is kinked. If not, remove the sampling line from the water trap. Then, if a prompt message indicating airway malfunction appears on the screen, it means that the water trap is occluded. In this case, you must replace the water trap. If no such prompt message is displayed, it means that the sampling line is occluded. Then you must replace the sampling line.

## 7.6 Zero the Sensor

Zeroing the sensor aims to eliminate the effect of baseline drift on the readings during the measurement so as to ensure measurement accuracy.

For CO2 module, a zero calibration is carried out automatically when necessary. You can also start a manual zero calibration when deemed necessary. To manually start a zero calibration, push the Menu key. Select [**System**] → [**CO2**] → [**Zero**]. You do not need to disconnect the sensor from the breathing system when performing the zeroing.

## 7.7 Calibrate the Sensor

For CO2 module, a calibration should be performed once a year or when the measured value has a great deviation. For details, refer to *11 Maintenance*.

# 8 Special Functions

---

---

## 8.1 Manual Breath

Push the Manual Breath key and the ventilator system delivers one breath to the patient in accordance with the current ventilation mode.

### NOTE

---

- **Pressing the Manual Breath key during inspiratory phase cannot initiate a manual breath.**
  - **Manual breath function is disabled in CPAP mode and is supported when apnea ventilation occurs.**
  - **Manual breath is disabled in standby status.**
- 

## 8.2 Expiration Hold

Expiration Hold means to extend the patient's time of expiratory phase manually and to prevent the patient from inspiration for a certain period of time.

Push and hold the Exp. Hold key. The ventilator starts the Expiration Hold function and the screen shows [**Exp. Hold Active**]. Release the Exp. Hold key. The ventilator terminates the Expiration Hold function. Expiration Hold is active for a maximum of 30 seconds. If the Exp. Hold key is pushed and held for more than 30 seconds or is released, the ventilator terminates the Expiration Hold function automatically.

During Expiration Hold, the ventilator calculates PEEP<sub>i</sub> automatically and displays the calculation results in the box as shown below.

### NOTE

---

- **There is at least one inspiratory phase between two expiration holds.**
  - **The system responds to Exp. Hold key pressing operation only in non-standby status.**
  - **Expiration Hold function is disabled in CPAP mode and is supported when apnea ventilation occurs.**
-

---

## 8.3 Inspiration Hold

Inspiration Hold means to extend the patient's time of inspiratory phase manually and to prevent the patient from expiration for a certain period of time.

Push and hold the Insp. Hold key. The ventilator starts the Inspiration Hold function and the screen shows [**Insp. Hold Active**]. Release the Insp. Hold key. The ventilator terminates the Inspiration Hold function. Inspiration Hold is active for a maximum of 30 seconds. If the Insp. Hold key is pushed and held for more than 30 seconds, the ventilator terminates the Inspiration Hold function automatically.

During Inspiration Hold, the ventilator calculates Cstat and Pplat automatically and displays the calculation results in the box as shown below.

### NOTE

---

- **There is at least one expiratory phase between two inspiration holds.**
  - **The system responds to Insp. Hold key pressing operation only in non-standby status.**
  - **Inspiration Hold function is disabled in CPAP mode and is supported when apnea ventilation occurs.**
- 

## 8.4 Nebulizer

During nebulization, aerosolized medicament is inhaled by the patient for the purpose of therapy.

Push the Nebulizer key and set the appropriate nebulization time. Select [**Ok**] to start nebulization. When the nebulizer is started up, the nebulizer indicator lamp is illuminated and the screen prompt message filed displays the remaining nebulization time.

When the set nebulization time expires or the Nebulizer key is pushed again, the ventilator terminates nebulization.

### NOTE

---

- **CO2 cannot be measured in the aerosolized medicament environment. CO2 module sampling and monitoring are suspended when the nebulizer is started.**
  - **Nebulization is disabled in V-A/C, V-SIMV and PRVC modes when patient type is pediatric.**
  - **Aerosolized medication may occlude the expiration valve and flow sensor. Please have them checked and cleaned after nebulization.**
-

---

## NOTE

---

- **Nebulization may cause fluctuation in the patient's FiO<sub>2</sub>.**
- 

## 8.5 O<sub>2</sub> ↑

The O<sub>2</sub> ↑ function means to deliver oxygen with concentration higher than the normal level.

When the O<sub>2</sub> ↑ key is pushed, the ventilator starts the O<sub>2</sub> ↑ function. The O<sub>2</sub> ↑ indicator lamp is illuminated and the screen prompt message filed displays the remaining O<sub>2</sub> ↑ time. O<sub>2</sub> ↑ is active for a maximum of two minutes. When O<sub>2</sub> ↑ is functioning, the [O<sub>2</sub>%] parameter in the parameter setup quick key field displays the currently set oxygen concentration.

When two minutes of O<sub>2</sub> ↑ expires or the O<sub>2</sub> ↑ key is pushed again, the ventilator terminates O<sub>2</sub> ↑ function. Removing the breathing hoses during O<sub>2</sub> ↑ starts the suction function.

## NOTE

---

- **When O<sub>2</sub> supply pressure is low, this function is not initiated, and is terminated automatically if this function is initiated already.**
- 

## 8.6 Suction

The ventilator provides a suction procedure to help the patient to complete suction.

1. Push the Menu key and select [**Procedure**].
2. Select [**Suction**] to access the suction procedure screen and activate the suction function.
  - ◆ When the suction procedure is activated, the system performs O<sub>2</sub> ↑ function and prompts [**O<sub>2</sub> ↑ Active. Please disconnect the patient after adequate O<sub>2</sub> is delivered.**]. If the patient hoses are not disconnected within the specified time, the suction procedure will end automatically.
  - ◆ After the patient hoses are disconnected, the system prompts [**The patient is disconnected. Please reconnect the patient after suction is completed.**] and stops ventilating the patient. In this case, manual suction can be applied to the patient.
  - ◆ After manual suction applied to the patient, re-connect the patient hoses. The system performs O<sub>2</sub> ↑ function and prompts [**O<sub>2</sub> ↑ Active. The patient is reconnected.**].

To stop an active suction procedure during O<sub>2</sub> ↑, select [**Exit**] or push the O<sub>2</sub> ↑ key.

---

## 8.7 P0.1

P0.1 is the pressure drop within the first 100 ms after a patient starts spontaneous breathing.

1. Push the Menu key. Select [**Tool**] and select [**Procedure**].
2. Select [**P0.1**] to access the P0.1 measure screen.
3. Select [**Start**]. The system starts P0.1 measurement and prompts [**Measurement Active**].
4. After the measurement is completed, the measurement result is displayed. The ventilator can display the last three measurement results.
5. After the measurement is completed, waveforms and spirometry data are frozen automatically.

### NOTE

---

- **During P0.1 measurement, pushing the Freeze key does not produce freezing operation.**
  - **If no operation is performed on P0.1 measurement screen within three minutes, the measurement screen exits automatically.**
- 

## 8.8 NIF

NIF is the maximum negative pressure generated by the patient's spontaneous breathing within a period of time.

1. Push the Menu key. Select [**Tool**] and select [**Procedure**].
2. Select [**NIF**] to access the NIF measure screen.
3. Push and hold the [**Press and Hold**] button on the screen or the Exp. Hold key on the display. The system starts NIF measurement.
4. Release the [**Press and Hold**] button or the Exp. Hold key. The measurement is completed. The measurement result is displayed. The ventilator can display the last three measurement results.

### NOTE

---

- **During NIF measurement, pushing the Freeze key does not produce freezing operation.**
  - **If no operation is performed on NIF measurement screen within three minutes, the measurement screen exits automatically.**
-

---

## 8.9 PEEPi

The PEEPi measure function supports measurement of two parameters—PEEPi and Vtrap. PEEPi is the positive end-expiratory pressure produced by the trapped gas and Vtrap is the trapped gas volume.

1. Push the Menu key. Select [**Tool**] and select [**Procedure**].
2. Select [**PEEPi**] to access the PEEPi measure screen.
3. Select [**Start**]. The system starts PEEPi measurement and prompts [**Measurement Active**].
4. After the measurement is completed, the measurement result is displayed. The ventilator can display the last three measurement results.
5. After the measurement is completed, waveforms and spirometry data are frozen automatically.

## 8.10 P-V Tool

Mechanical ventilation set with the optimal PEEP can improve oxygenation, improve alveolar mechanics and reduce injury to the lungs. By drawing static pressure-volume curve (static P-V loop), P-V tool is the method to determine the optimal PEEP based on the characteristic points on the static P-V curve. The doctor is able to determine the optimal PEEP for the patient with the help of this function. After the P-V tool function is enabled, PEEP is first adjusted to be equal to the set Pstart. Then gas is delivered at constant flow and expiration is performed at constant flow. Inspiration trigger is forbidden during ventilation. When static P-V loop measurement is completed, ventilation is restored automatically with the previous vent mode and parameters.

The typical ventilation curves with static P-V tool function are shown below:

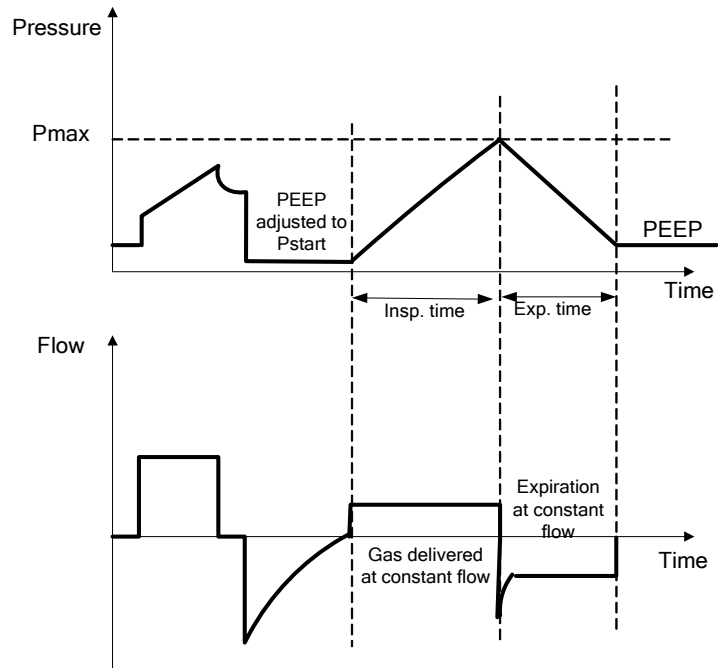

The typical static P-V loop is as shown below:

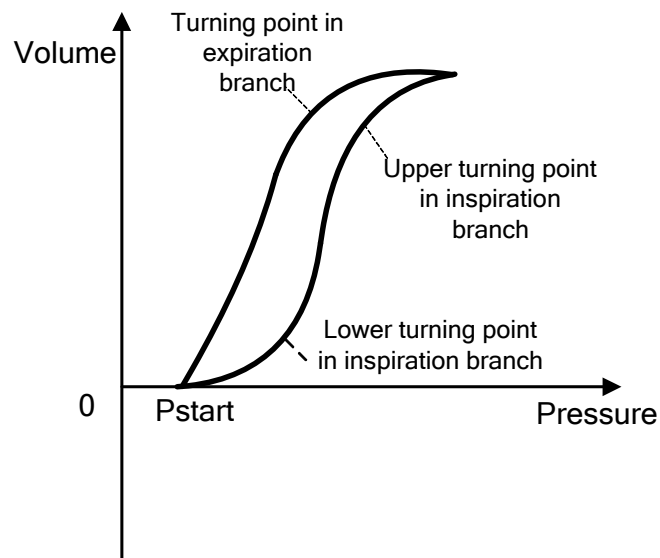



---

## NOTE

---

- **The P-V tool function is disabled in the following cases: patient type of Ped, CPAP/PSV, NIV or apnea vent mode, within one minute after nebulization or suction, within one minute after last P-V loop test.**
  - **The P-V tool function is not recommended when there is great leakage or when the patient has spontaneous breathing. The relevant characteristic points the P-V tool function provides are only for your reference.**
- 

1. Push the Menu key. Select [**T**ool] and select [**P**rocedure].
2. Select [**P-V Tools**] to access the P-V tools screen.
3. Read P-V tool related notes on the screen.
4. Select [**P**rocedure] and set Pstart, Flow, Pmax and Vlimit parameters on the Procedure screen. The system acquires Tmax parameter value based on the calculation formula and displays it on the menu screen.
  - ◆ Flow: gas delivery and expiration flows of the static P-V loop.
  - ◆ Pstart: starting pressure of the static P-V loop.
  - ◆ Pmax: maximum pressure which the static P-V loop can reach.
  - ◆ Vlimit: maximum volume which the static P-V loop can reach.
  - ◆ Tmax: maximum measurement time required for completing static P-V loop measurement.
5. Select [**S**tart] and the system starts P-V tool measurement. If you select [**S**top Insp] during measurement, the system stops inspiration measurement test immediately and starts expiration measurement. If you select [**A**bort] during measurement, the system aborts measurement immediately.

- After the measurement is completed, the system enters Analysis screen. Characteristic points are displayed automatically on the P-V loop. You can set the desired positions of [Cursor 1] and [Cursor 2]. When you select [Cursor 1] or [Cursor 2], the selected cursor turns red. You can move the position of the cursor via the control knob to determine the characteristic points. The system also displays the volume value and pressure value of the inspiration and expiration branches corresponding to the cursor position and displays the compliance of these branches, as shown below.

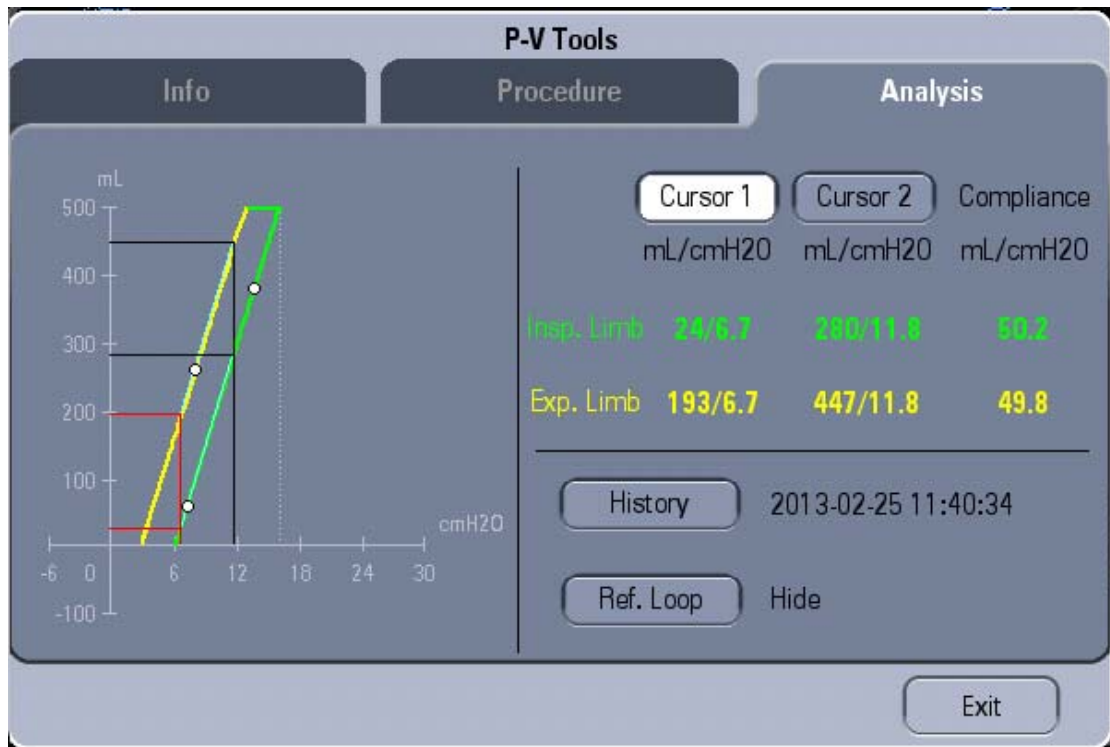

- Select [**History**] to select the desired loop in the accessed list. The system only displays the history loop you are viewing.
- Select [**Ref. Loop**] to select the desired loop in the accessed list. The system displays the reference loop you are viewing and the current loop as well.

# 9 Alarms

---

---

## 9.1 Introduction

Alarms, triggered by a vital sign that appears abnormal or by technical problems of the ventilator, are indicated to the user by visual and audible alarm indications.

### NOTE

---

- **When the ventilator is started, the system detects whether audible alarm tones and alarm lamp function normally. If yes, the equipment gives a beep, also the alarm lamp flashes red and yellow successively. If not, do not use the equipment and contact us immediately.**
  - **When multiple alarms of different levels occur simultaneously, the ventilator selects the alarm of the highest level and gives visual and audible alarm indications accordingly.**
- 

## 9.2 Alarm Categories

By nature, the ventilator's alarms fall into three categories: physiological alarms, technical alarms and prompt messages.

### 1. Physiological alarms

Physiological alarms, also called patient status alarms, are triggered by a monitored parameter value that violates set alarm limits or an abnormal patient condition.

Physiological alarm messages are displayed in the alarm message field.

### 2. Technical alarms

Technical alarms, also called system status alarms, are triggered by a device malfunction or a patient data distortion due to proper operation or mechanical problems. Technical alarm messages are displayed in the alarm message field.

### 3. Prompt messages

As a matter of fact, prompt messages are not alarm messages. Apart from the physiological and technical alarm messages, the ventilator will show some messages telling the system status. Messages of this kind are included into the prompt message category and are usually displayed in the prompt message field.

---

## 9.3 Alarm Levels

By severity, the ventilator's alarms fall into three categories: high level alarms, medium level alarms and low level alarms.

1. High level alarms

Indicates that the patient is in a life threatening situation and an emergency treatment is demanded.

2. Medium level alarms

Indicates that the patient's vital signs appear abnormal and an immediate treatment is required.

3. Low level alarms

Indicates that the patient's vital signs appear abnormal and an immediate treatment may be required.

The level for all technical alarms and physiological alarms are preset before the ventilator leaves the factory and are not user adjustable.

## 9.4 Alarm Indicators

When an alarm occurs, the ventilator will indicate it to the user through visual or audible alarm indications.

- Alarm lamp.
- Alarm message.
- Flashing numeric.
- Audible alarm tones.

### 9.4.1 Alarm Lamp

If a technical alarm or physiological alarm occurs, the alarm lamp will flash. The flashing color and frequency match the alarm level as follows:

- High level alarms: the lamp quickly flashes red.
- Medium level alarms: the lamp slowly flashes yellow.
- Low level alarms: the lamp turns yellow without flashing.

---

## 9.4.2 Audible Alarm Tones

The ventilator uses different alarm tone patterns to match the alarm level:

- High level alarms: broadcasts the high level alarm sound.
- Medium level alarms: broadcasts the medium level alarm sound.
- Low level alarms: broadcasts the low level alarm sound.

### NOTE

- 
- The ventilator's alarm signal sound pressure level is lower than 85 dB.
- 

## 9.4.3 Alarm Message

When an alarm occurs, an alarm message will appear in the ventilator's alarm message filed.

The alarm message uses a different background color to match the alarm level:

- High level alarms: red
- Medium level alarms: yellow
- Low level alarms: yellow

The prompt messages displayed in the prompt message filed have no background color.

For physiological alarms, the asterisk symbols (\*) before the alarm message match the alarm level as follows:

- High level alarms: \*\*\*
- Medium level alarms: \*\*
- Low level alarms: \*



## 9.4.4 Flashing Alarm Numeric

If an alarm triggered by an alarm limit violation occurs, the numeric of the measure parameter in alarm will flash at a specified frequency.

---

## 9.4.5 Alarm Status Symbol

Apart from the aforementioned alarm indicators, the ventilator still uses the following symbols telling the alarm status:

-  indicates alarm silenced.
-  indicates multiple alarm messages. The alarm message uses a different background color to match the alarm level. Red background means that the highest level of the multiple alarm messages is high while yellow background means that the highest level of the multiple alarm messages is medium.

## 9.5 Set Alarm Volume

Push the Alarm Setup key. Select [**Alarm Limits**] and then [**Alarm Volume**]. Select the appropriate value ranging from 1 to 10. The value 1 is for the lowest and 10 for the loudest.

---

### **WARNING**

- **Do not rely exclusively on the audible alarm system when using the ventilator. Adjustment of alarm volume to a low level may result in a hazard to the patient. Always keep the patient under close surveillance.**
- 

## 9.6 Set Alarm Limits

### **NOTE**

- **An alarm is triggered when the parameter value is higher than the high limit or lower than the low limit.**
  - **When using the ventilator, always keep an eye to whether the alarm limits of a specific parameter are set to the appropriate values.**
- 

Push the Alarm Setup key and select [**Alarm Limits**]. You can set the alarm limits for Paw, MV, f<sub>tot</sub>, T<sub>Ve</sub>, FiCO<sub>2</sub>, or EtCO<sub>2</sub>. Among these parameters, the low alarm limits for some parameters are factory-preset and are not user adjustable.

---

## 9.7 Set Apnea Time

Push the Alarm Setup key and select [**Alarm Limits**]. Set Tapnea to an appropriate value. If no breathing activity is detected longer than the set Tapnea, an apnea alarm is triggered.

## 9.8 Alarm Silence

### 9.8.1 How to Set Alarm Silence

Push the Alarm Silence key to silence alarm audio of an active alarm for 120 seconds.

#### NOTE

---

- **When alarm is silenced, all the alarm indicators work normally except audible alarm tones.**
  - **When alarm is silenced, if a new technical or physiological alarm occurs, the current alarm silenced status ends automatically and audible alarm tones are restored.**
  - **When the 120 s countdown time is up, the current alarm silenced status is cancelled and audible alarm tones are restored.**
- 

### 9.8.2 How to Cancel Alarm Silence

When alarm is silenced, pushing the Alarm Silence key or triggering a new alarm will cancel the current alarm silenced status and restore audible alarm tones. The alarm silence symbol and 120s countdown will disappear at the same time.

---

## 9.9 Alarm Reset

Latching alarms: the system continues displaying the alarm message even if the alarm conditions end except that:

- Alarm audio disappears;
- Alarm LED stops flashing and is permanently lit with the same color;
- Alarm message is displayed without background color;
- The alarmed parameter measured value stops flashing.

Push the Alarm Reset key to clear all latched alarms when alarm latching is switched on.

### NOTE

- 
- **There are three latching alarms: Apnea ventilation, Battery in Use, Pressure Limited.**
- 

## 9.10 Nurse Call

The ventilator provides nurse call function, which means that the ventilator outputs nurse call signals to the nurse call system when an alarm which meets the user set requirements occurs.

The nurse call function is activated only when:

1. The nurse call function is switched on;
2. An alarm which meets the user set requirements occurs;
3. The ventilator is not in alarm silenced status.

Follow these steps to set nurse call:

1. Push the Menu key. Select [**Maintain**] and select [**User**]. Enter the required password. Then select [**Nurse Call**].
2. Select [**Switch**] and toggle between [**ON**] and [**OFF**].
  - ◆ [**ON**]: to switch on the nurse call function.
  - ◆ [**OFF**]: to switch the nurse call function off.
3. Select [**Signal Type**] and toggle between [**Pulse**] and [**Continuous**].
  - ◆ [**Pulse**]: indicates that the nurse call signals outputted are pulse signals lasting for one second. When multiple alarms occur simultaneously, only one pulse signal is outputted. If a new alarm occurs while the ongoing alarm is not cleared yet, a new pulse signal will be outputted.



- 
- ◆ [Continuous]: indicates that the nurse call signal lasts until the alarm ends, i.e. the duration of a nurse call signal equals to that of the alarm.
4. Select [Contact Type] and toggle between [Normally Open] and [Normally Closed].
    - ◆ [Normally Open]: normally open signals are used to trigger the nurse call function.
    - ◆ [Normally Closed]: normally closed signals are used to trigger the nurse call function.
  5. Select [Alarm Level] and set the alarm level for nurse call signals triggered alarm.
  6. Select [Alarm Type] and select the alarm type to which nurse call signals triggered alarm belongs.

If no setting is made for [Alarm Level] or [Alarm Type], nurse call signals will not be triggered whatever alarm occurs.

---

## WARNING

---

- Do not rely exclusively on the nurse call system for alarm notification. Remember that the most reliable alarm notification combines audible and visual alarm indications with the patient's clinical condition.
  - Use the specified nurse call cable when connecting with the hospital's nurse call system through the nurse call connection port. Failure to do so may burn the machine and produce electric shock hazard.
- 

## 9.11 Alarm Test

### 9.11.1 Battery in Use Alarm

1. Connect the ventilator to the AC power, push  hard key.
2. After the system powers on, disconnect the AC power.
3. Check if [Battery in Use] alarm is triggered, and the ventilator is powered by batteries.
4. Reconnect the AC power.
5. Check if [Battery in Use] alarm is reset, and the ventilator is powered by AC power.

### 9.11.2 Battery Depletion Alarm

1. Connect the ventilator to the AC power, push  hard key.
2. After the system powers on and the battery is already fully charged, disconnect the AC power.

- 
3. Connect the test lung to the ventilator, and start the ventilation normally.
  4. For the ventilator configured with one battery, the battery capacity is depleted after 90 minutes' ventilation (for the ventilator configured with two batteries, the battery capacity is depleted after 180 minutes' ventilation). [**System DOWN for battery depletion!**] alarm is triggered.
  5. Reconnect the AC power.
  6. Check if [**System DOWN for battery depletion!**] alarm is reset, and the ventilator is powered by AC power.

### 9.11.3 Paw Too High Alarm

1. After the system is powered on normally, connect the test lung to the ventilator and start ventilation.
2. Set the airway pressure alarm high limit to the current P<sub>peak</sub> +5cmH<sub>2</sub>O.
3. Press the test lung in the inspiratory phase.
4. Check if [**Paw Too High**] alarm is triggered, if the ventilation cycle enters inspiratory phase, and if airway pressure is reduced to the value of PEEP.

### 9.11.4 TV Not Achieved Alarm

1. After the system is powered on normally, connect the test lung to the ventilator and start ventilation.
2. Disconnect the VBS pipe from the test lung, and check if [**TV Not Achieved**] alarm is triggered.

### 9.11.5 MV Too Low Alarm

1. After the system is powered on normally, connect the test lung to the ventilator and start ventilation.
2. Set MV alarm low limit to be larger than the current MV, and check [**MV Too Low**] alarm is triggered.

### 9.11.6 O2 Supply Pressure Low Alarm

1. Connect high pressure O<sub>2</sub> supply and air supply to the ventilator.
2. After the ventilation is normal, close the high pressure O<sub>2</sub> supply, and check if [**O<sub>2</sub> Supply Pressure Low**] alarm is triggered.

---

### 9.11.7 Air Supply Pressure Low Alarm

1. Connect high pressure O<sub>2</sub> supply and air supply to the ventilator.
2. After the ventilation is normal, close the high pressure air supply, and check if [**Air Supply Pressure Low**] alarm is triggered.

### 9.11.8 Airway Obstructed Alarm

1. After the system is powered on normally, connect the test lung to the ventilator and start ventilation.
2. Disconnect the Y-pipe and the test lung, and put the leak test plug in the Y-pipe.
3. After several breathing cycles, check if [**Airway Obstructed**] alarm is triggered.

### 9.11.9 FiO<sub>2</sub> Too High Alarm

1. Connect high pressure O<sub>2</sub> supply and air supply to the ventilator.
2. Connect the test lung to the ventilator and set the oxygen concentration to 40%. Start the ventilation.
3. After the ventilation is stable, disconnect the high pressure air supply.
4. After several breathing cycles, check if [**FiO<sub>2</sub> Too High**] alarm is triggered.

### 9.11.10 FiO<sub>2</sub> Too Low Alarm

1. Connect high pressure O<sub>2</sub> supply and air supply to the ventilator.
2. Connect the test lung to the ventilator and set the oxygen concentration to 40%. Start the ventilation.
3. After the ventilation is stable, disconnect the high pressure O<sub>2</sub> supply.
4. After several breathing cycles, check if [**FiO<sub>2</sub> Too Low**] alarm is triggered.

### 9.11.11 EtCO<sub>2</sub> Too High Alarm

1. Connect the test lung to the ventilator, and start ventilation.
2. Connect the CO<sub>2</sub> test module to the ventilator, and set the CO<sub>2</sub> test module to working condition.

- 
3. After the CO<sub>2</sub> test module finishes the preheating and enters in the working status, connect the CO<sub>2</sub> of 3% to 7% to the simple port of the sidestream CO<sub>2</sub> module or the airway adapter of the mainstream CO<sub>2</sub> module. Set the EtCO<sub>2</sub> high alarm limit to be lower than the concentration of the standard gas.
  4. Check if [**EtCO<sub>2</sub> Too High**] alarm is triggered.

### 9.11.12 EtCO<sub>2</sub> Too Low Alarm

1. Connect the test lung to the ventilator, and start ventilation.
2. Connect the CO<sub>2</sub> test module to the ventilator, and set the CO<sub>2</sub> test module to working condition.
3. After the CO<sub>2</sub> test module finishes the preheating and enters in the working status, connect the standard CO<sub>2</sub> of 3% to 7% to the simple port of the sidestream CO<sub>2</sub> module or the airway adapter of the mainstream CO<sub>2</sub> module. Set the EtCO<sub>2</sub> high alarm limit to be higher than the concentration of the standard gas.
4. Check if [**EtCO<sub>2</sub> Too Low**] alarm is triggered.

## 9.12 Alarm Logbook

For alarm logbook, the system provides up to 500 events which are stored in chronological order. When a new event occurs after 500 events are already stored, the earliest event will be overwritten by the new one. Each alarm log includes the ventilation mode, ventilation type (NIV or non-NIV), patient type (adult or pediatric), operating mode (standby or non-standby mode), and monitored parameters.

To access the Alarm Logbook window, push the Alarm Setup key and select [**Alarm Logbook**]. In the Alarm Logbook window, you can:

1. Select [**Scroll**] to view the alarm events item by item.
2. Select [**Alarm Level**] and select the desired level of alarms to be displayed. The options include all level, high level, medium level, and low level.

### NOTE

- 
- **After the ventilator is started up, if [Same Patient] is applied, the system will store the previous alarm log and continue recording. If [New Patient] is applied, the system will clear the previous alarm log and record anew.**
-

---

## 9.13 When an Alarm Occurs

When an alarm occurs, do as follows:

1. Check the patient's condition.
2. Determine the alarming parameter or alarm category.
3. Identify the alarm source.
4. Take proper actions to eliminate the alarm condition.
5. Make sure the alarm condition is corrected.

For details about how to troubleshoot alarms, refer to *D Alarm Messages*.

---

**FOR YOUR NOTES**

# 10 Cleaning and Disinfection

---

---

## **WARNING**

---

- Obey applicable safety precautions.
  - Read the material safety data sheet for each cleaning agent.
  - Read the operation and service instructions for all disinfection equipment.
  - Wear gloves and safety glasses. A damaged O<sub>2</sub> sensor can leak and cause burns (contains potassium hydroxide).
  - Reuse of undisinfected reusable accessories or components may cause cross-contamination.
  - To prevent leaks, avoid damaging any component in case of disassembling and reassembling the breathing system. Ensure the correct installation of the system. Make sure of the applicability and correctness of the cleaning and disinfection methods.
  - Disassemble and reassemble the breathing system as described in this manual. For further disassembly and reassembly, contact us. Improper disassembling and reassembling may cause breathing system leak and compromise normal system use.
  - Seeping liquid into the control assembly can damage the equipment or cause personal injury. When cleaning the housing, make sure that no liquid flows into the control assemblies and always disconnect the equipment from the AC mains. Reconnect the AC mains after the cleaned parts are fully dry.
  - Do not use talc, zinc stearate, calcium carbonate, corn starch or equivalent materials to prevent tackiness. These materials can go into the patient's lungs and airways and cause irritation or injury.
- 

## **NOTE**

---

- Clean and disinfect the equipment as required before it is put into use for the first time. Refer to this chapter for the cleaning and disinfection methods.
  - To help prevent damage, refer to the manufacturer's data if you have questions about a cleaning agent.
  - Do not use organic, halogenated, or petroleum based solvents, anesthetic agents, glass cleaners, acetone, or other harsh cleaning agents.
  - Do not use abrasive cleaning agents (such as steel wool, silver polish or cleaner).
  - Keep all liquids away from electronic parts.
-

---

## NOTE

---

- Do not permit liquid to go into the equipment housings.
  - Only autoclave parts marked 134° C.
  - Cleaning solutions must have a pH of 7.0 to 10.5.
  - The expiration valve assembly and patient hose of the gas pathways through the ventilator can become contaminated with body fluids and expired gases during both NORMAL CONDITION and SINGLE FAULT CONDITION.
- 

## 10.1 Methods for Cleaning and Disinfection

Parts marked **134°C** are autoclavable. Maximum recommended temperature is 134° C. By using autoclave to solidify bacterioproten rapidly, quick and reliable sterilization effect can be achieved.

All parts of the ventilator can be cleaned and disinfected. The cleaning and disinfection methods vary from parts to parts. You need to select the appropriate method to clean and disinfect the parts based on the actual situations to avoid cross-contamination between the ventilator user and the patient.

This table is our recommended cleaning and disinfection methods for all parts of the ventilator, including use for the first time and use after many times.

Parts	Recommended frequency	Cleaning		Disinfection			
		①	②	A*	B*	C*	D*
<b>Ventilator Housing</b>							
Ventilator housing (including touch screen)	Each patient	①		A* or D*			
Power cord and supply gas hose	Each patient	①		A* or D*			
Fan filter (filter at air intake vent)	Every four weeks/as necessary*	②		D*			
Inspiratory dust filter	Weekly/as necessary*	②		D*			
Cart and support arm	Each patient	①		A* or D*			
<b>Expiration valve assembly</b>							
Expiration valve flow sensor	Each patient/weekly	②		B* Note: soaked in glutaraldehyde solution.			
Expiration valve assembly (including check valve)	Each patient/weekly	②		B* or C*			



<b>Patient hose</b>			
Patient hose (including water trap and Y piece)	Each patient/weekly	②	B* or C*
<b>Compressor</b>			
Housing	Each patient	①	A* or D*
Filter at air intake vent	Every 250 hours/as necessary*	②	D*
<b>Other</b>			
Nebulizer	Each patient/weekly	Refer to the cleaning and disinfection methods provided by the nebulizer vendor.	
Humidifier	Each patient/weekly	Refer to the cleaning and disinfection methods provided by the humidifier vendor.	
<b>Cleaning methods (Wipe and Bath Immersion):</b>			
① Wipe: wipe with a damp cloth immersed in alkalescent detergent (soap water etc.) or alcohol solution and then wipe off the remaining detergent with a dry lint free cloth.			
② Immersion: flush with water first and then immersed in alkalescent detergent (soap water etc.) (water temperature 40°C recommended) for approximately three minutes. Finally clean with water and dry completely.			
<b>Disinfection methods (Autoclave):</b>			
A* Wipe: wipe with a damp cloth immersed in medium- or high-efficiency detergent (alcohol or isopropyl alcohol etc.) and then wipe off the remaining detergent with a dry lint free cloth.			
B* Immersion: immersed in medium- or high-efficiency detergent (alcohol or isopropyl alcohol etc.) for more than 30 minutes (recommended time). Then clean with water and dry completely.			
C* Steam autoclave at maximum 134°C for more than 20 minutes (recommended time).			
D* Ultraviolet radiation for 30 to 60 minutes (recommended time).			

As necessary\*: shorten the cleaning and disinfection intervals if the equipment is used in dusty environment to ensure that the equipment surface is not covered by dust.

The table below lists the cleaning and disinfecting agents and autoclaving process that may be used on the ventilator.

<b>Name</b>	<b>Type</b>
Ethanol (75%)	Intermediately efficient disinfectant
Isopropanol(70%)	Intermediately efficient disinfectant
Glutaraldehyde (2%)	Highly efficient disinfectant
Soap water (pH value of 7.0~10.5)	Disinfectant
Clean water	Disinfectant
Steam autoclave*	Highly efficient disinfection

Steam autoclave\*: The maximum temperature of this disinfection method can reach 134°C (273°F). Some parts cannot be steam autoclaved.

---

## 10.2 Disassemble the Ventilator's Cleanable Parts

### 10.2.1 Expiration Valve Assembly

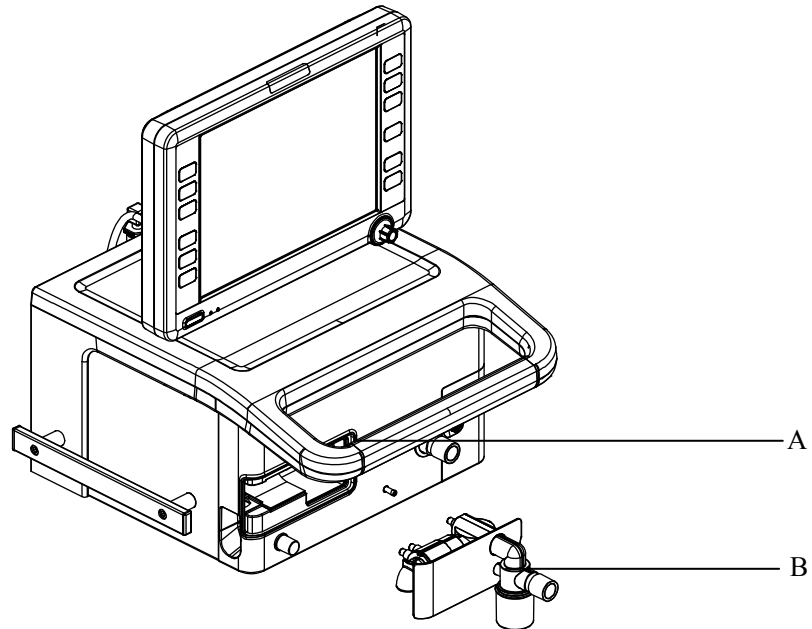

A. Expiration valve locker knob

B. Expiration valve assembly

- To disassemble the expiration valve assembly:

Push the expiration valve locker knob toward the inspiratory port and then pull out the expiration valve assembly with force.

- To install the expiration valve assembly:

Push the expiration valve assembly into the corresponding connector and make sure that it is in position.

---

## 10.2.2 Expiration Valve Flow Sensor

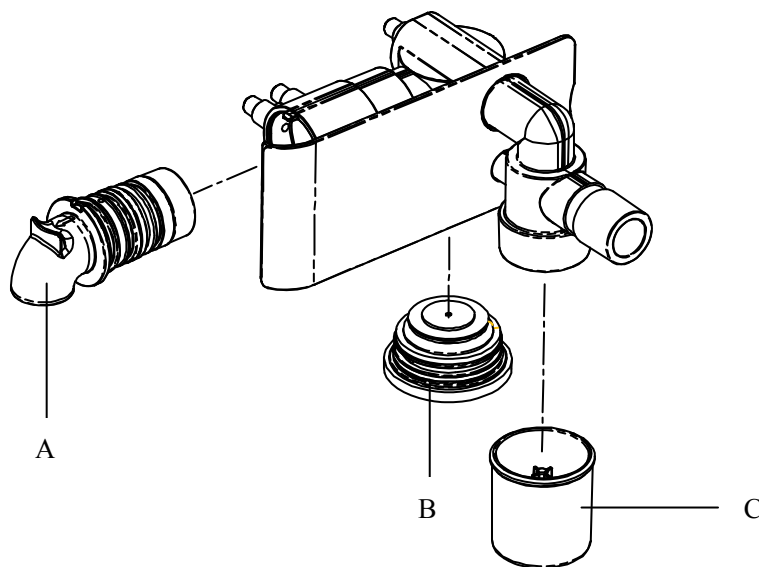

A. Flow sensor

- To disassemble the flow sensor:

Pull out the flow sensor horizontally from the expiration valve assembly.

- To install the flow sensor:

Insert the flow sensor horizontally into the expiration valve assembly in the direction as the arrow shows.

B. Expiration valve cover assembly

- To disassemble the expiration valve cover assembly

Rotate the expiration valve cover assembly to remove it from the expiration valve assembly.

- To install the expiration valve cover assembly

Insert the expiration valve cover assembly into the expiration valve assembly and rotate the expiration valve cover assembly until they are fully engaged.

C. Water trap

- To disassemble the water trap

Pull down the water trap to take it out.

- To install the water trap

Push up the water trap to the position.

### NOTE

- **Make sure that the arrow shows the gas flow direction when inserting the flow sensor into the expiration valve assembly horizontally.**
-

---

### 10.2.3 Water Trap

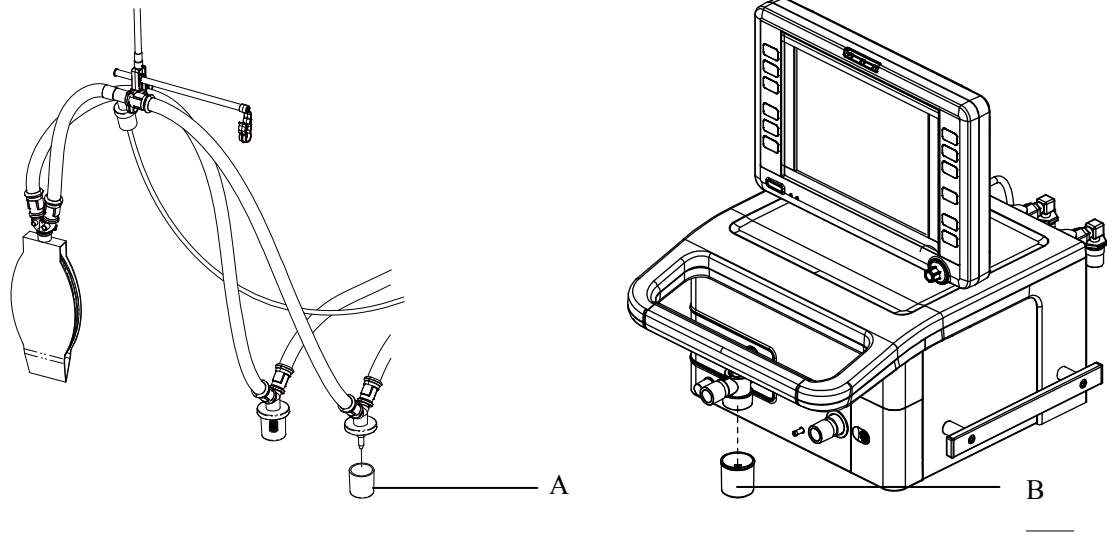

- A. Water trap on the breathing hose      B. Water trap on the expiration valve assembly

- To disassemble the water trap:  
Rotate the water trap gently to take it out.
  
- To install the water trap:  
Rotate to push in the water trap upward. Ensure that the water trap is installed in place.

---

## 10.2.4 Breathing Hoses

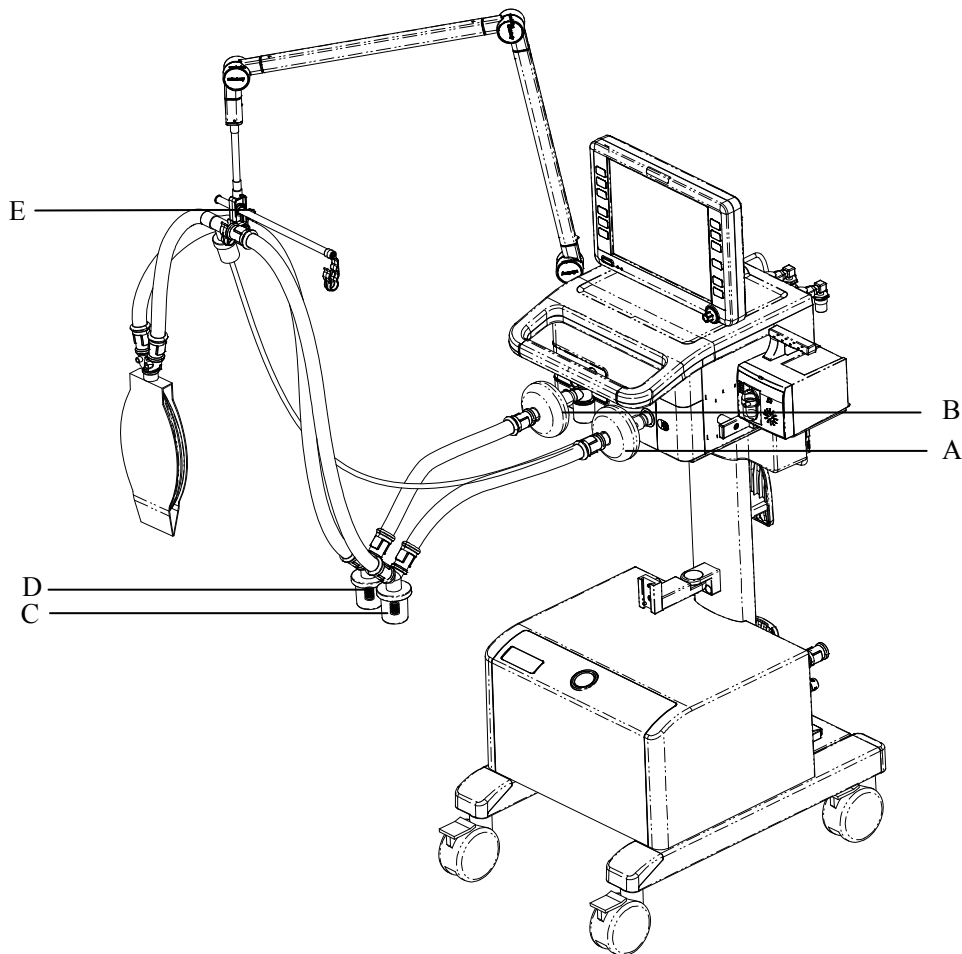

- |                           |                          |
|---------------------------|--------------------------|
| A. Inspiratory filter     | B. Expiratory filter     |
| C. Inspiratory water trap | D. Expiratory water trap |
| E. Support arm hook       |                          |

■ To disassemble the breathing hoses:

Pull out the breathing hoses one by one.

■ To install the breathing hoses:

1. Mount the filters onto the inspiratory and expiratory ports.
2. Connect the inspiratory filter to the water trap via the hose. Connect the other end of the hose to the Y piece.
3. Connect the expiratory filter to the water trap via the hose. Connect the other end of the hose to the Y piece.
4. Place the breathing hoses onto the support arm hook.

---

## 10.2.5 Nebulizer

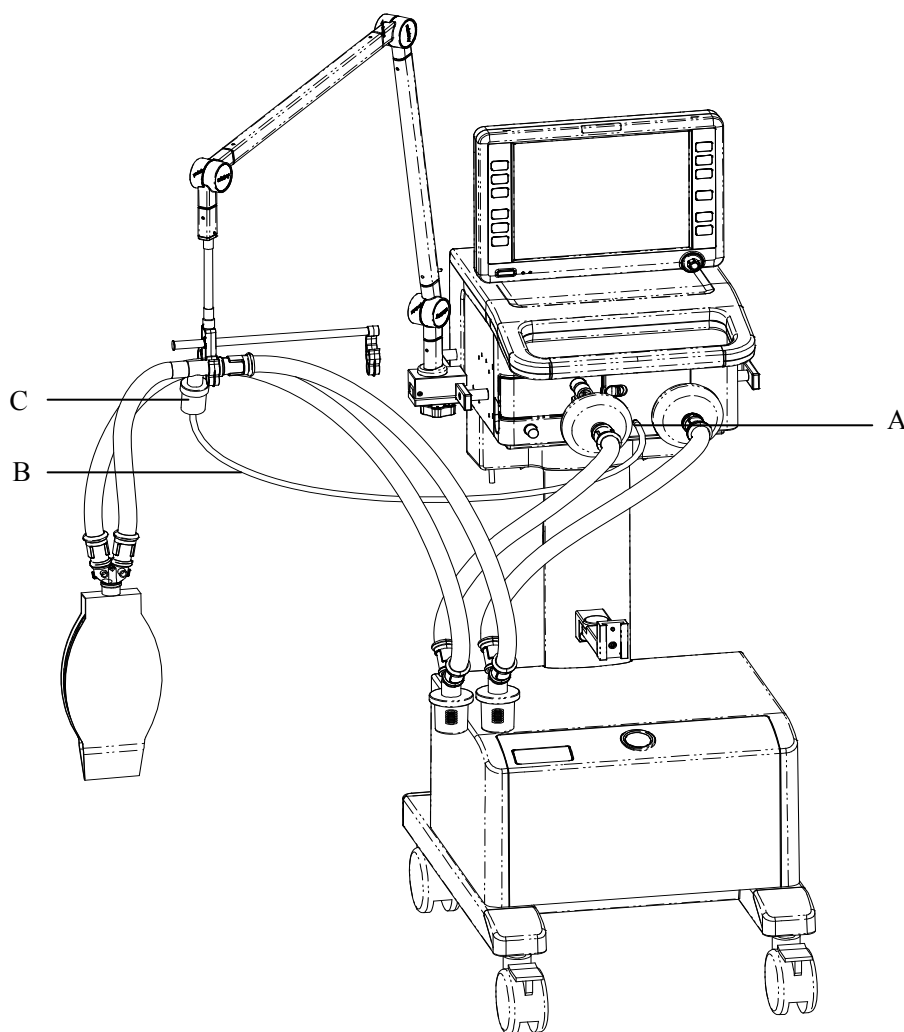

A. Nebulizer connector

B. Nebulizer hose

C. Nebulizer

■ To disassemble the nebulizer:

1. Pull out the nebulizer hose from the nebulizer connection.
2. Pull out the nebulizer from the inspiratory hose.

■ To install the nebulizer:

1. Connect one end of the nebulizer hose to the nebulizer connector and the other end of the hose to the nebulizer.
2. Mount the nebulizer onto the inspiratory hose via the hose.

### Note

- The nebulizer assembly and its installation steps described here are only for reference.

---

---

**⚠ WARNING**

---

- Nebulization yields the best performance at flow of 6 L/min. Nebulizers with other flows can create significant errors in tidal volume and oxygen mix.
- 

## 10.2.6 Humidifier

### Note

- Install the humidifier which complies with the specification. The humidifier assembly and its installation steps described here are only for reference.
- 

### 10.2.6.1 Humidifier Installed onto the Ventilator

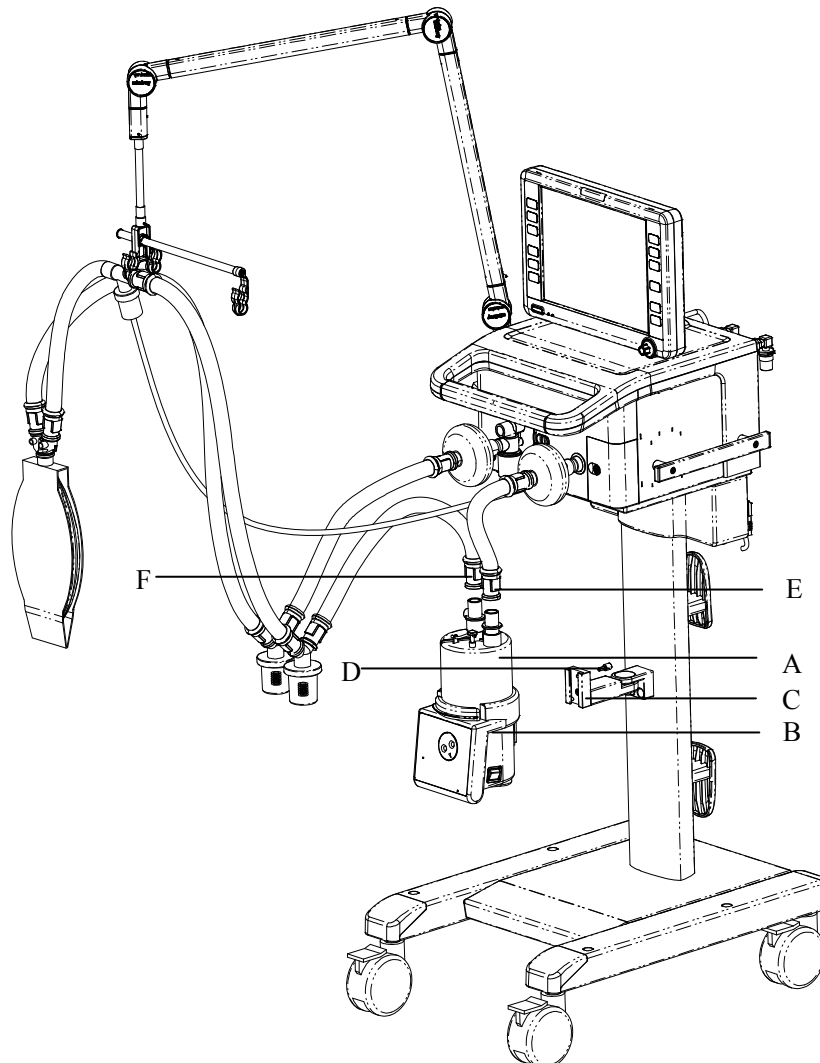

- 
- A. Humidifier
  - B. Humidifier sliding wheel
  - C. Humidifier bracket fixed seat
  - D. Screw
  - E. Humidifier inlet
  - F. Humidifier outlet

■ To disassemble the humidifier:

1. Remove the hoses connected to the humidifier.
2. Remove the screws.
3. Lift off the humidifier from the humidifier bracket fixed seat.

■ To install the humidifier:

1. Align the humidifier sliding wheel with the humidifier bracket fixed seat and slide in the humidifier.
2. Tighten the screw.
3. Mount the filters onto the inspiratory and expiratory ports.
4. Connect the inspiratory filter to the humidifier inlet via the hose.
5. Connect the humidifier outlet to the water trap via the hose. Then, connect the water trap to the Y piece via the hose.
6. Connect the expiratory filter to the water trap via the hose. Then, connect the water trap to the Y piece via the hose.
7. Place the breathing hoses onto the support arm hook.



---

### 10.2.6.2 Humidifier Installed onto the Pendant

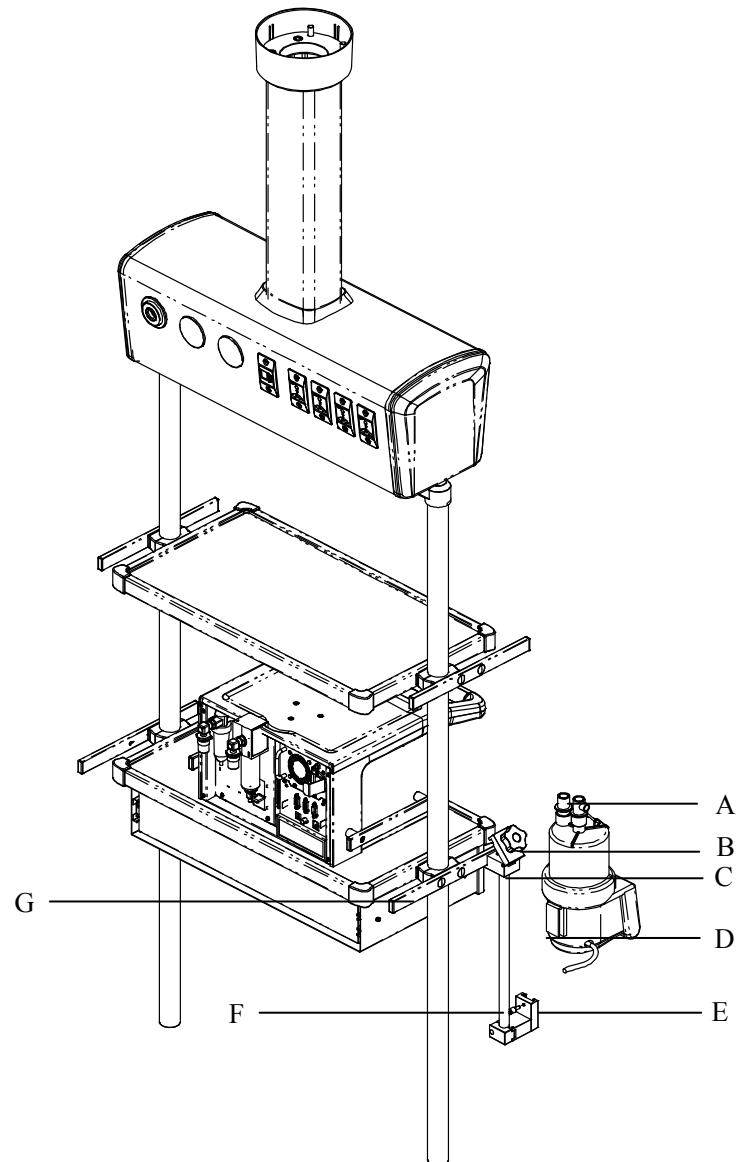

- A. Humidifier                      B. Knob for fixing block  
C. Fixing block                    D. Humidifier sliding wheel  
E. Humidifier bracket fixed seat F. Screw    G. Beam

■ To disassemble the humidifier:

1. Remove the hoses connected to the humidifier.
2. Remove the screws.
3. Lift off the humidifier from the humidifier bracket fixed seat.

- 
- To install the humidifier:
    1. Loosen the knob for fixing block. Put the fixing blocking onto the pendant beam.
    2. Tighten the knob for fixing block.
    3. Align the humidifier sliding wheel with the humidifier bracket fixed seat and slide in the humidifier.
    4. Tighten the screws.
    5. Install the breathing hoses. For details, refer to steps 3 through 7 in *10.2.6.1*.
- 

**⚠ WARNING**

- **When installing the humidifier, make sure that the humidifier connector shall be lower than the ventilator's breathing connectors and the patient.**
- 

### 10.2.7 O<sub>2</sub> Sensor

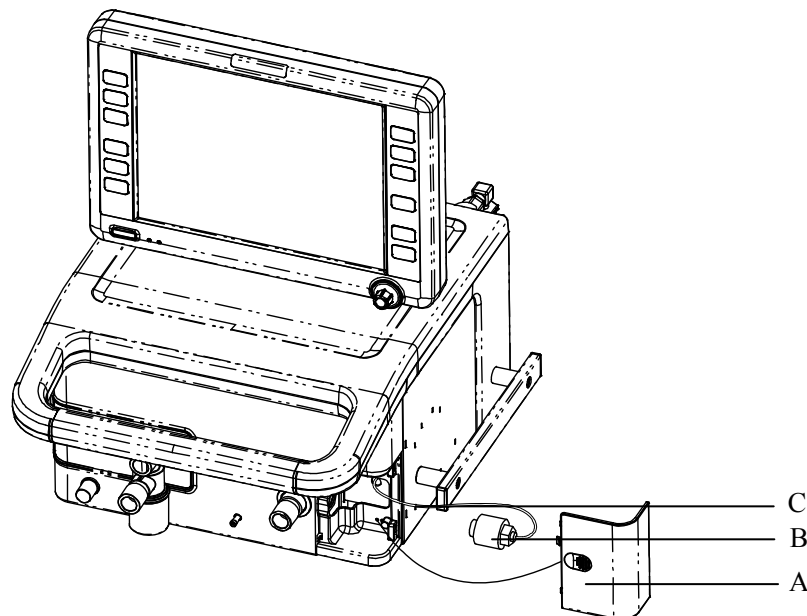

- A. O<sub>2</sub> sensor door    B. O<sub>2</sub> sensor    C. O<sub>2</sub> sensor connection line

- To disassemble the O<sub>2</sub> sensor:
  1. Remove the O<sub>2</sub> sensor door.
  2. Remove the O<sub>2</sub> sensor connection line.
  3. Rotate the O<sub>2</sub> sensor counter-clockwise to remove it.
- To install the O<sub>2</sub> sensor:
  1. Rotate the O<sub>2</sub> sensor clockwise to install it.
  2. Connect the O<sub>2</sub> connection line.
  3. Close the O<sub>2</sub> sensor door.

# 11 Maintenance

---

---

## 11.1 Repair Policy

---

### **WARNING**

---

- **Obey infection control and safety procedures. Used equipment may contain blood and body fluids.**
  - **Movable parts and removable components may present a pinch or a crush hazard. Use care when moving or replacing system parts and components.**
  - **Only use lubricants approved for ventilation or O2 equipment.**
  - **Do not use lubricants that contain oil or grease. They burn or explode in high O2 concentrations.**
- 

Do not use malfunctioning ventilator. Have all repairs and service done by an authorized service representative. Replacement and maintenance of the parts listed in this manual may be undertaken by a competent, trained individual having experience in the repair of devices of this nature.

After repair, test the ventilator to ensure that it is functioning properly, in accordance with the specifications.

### **NOTE**

---

- **No repair should ever be attempted by anyone not having experience in the repair of devices of this nature.**
  - **Replace damaged parts with components manufactured or sold by us. Then test the unit to make sure that it complies with the manufacturer's published specifications.**
  - **Contact us for service assistance.**
  - **For further information about the product, contact us. We can provide documents about some parts depending on the actual condition.**
-

## 11.2 Maintenance Schedule

Minimum frequency	Maintenance
During cleaning and setup	Inspect the parts for damage. Replace as necessary.
Several times a day or as necessary	Check the breathing hoses and water traps for water build-up. Empty water build-up if there is.
Daily or as necessary	<p>Clean the external surfaces.</p> <p>Calibrate the O2 sensor.</p> <p>Check the filter water trap at the O2 gas supply inlet (drain the water manually). If there is water build-up, press the spring pin upward at the bottom of the water trap to drain the water (if water is drained in ventilation status, water may splash. It is recommended to drain the water in gas cut-off status and use a container for drainage to prevent water from splashing onto the electrical plug underneath). After water drainage is completed, the spring pin returns to the original position automatically. If cracks or leaks are found on the water trap, contact the service personnel.</p> <p>Check the filter water trap at the Air gas supply inlet (drain the water manually). If there is water build-up, rotate the black handle at the bottom of the filter water trap gently (clockwise or counterclockwise). The water can be drained when the handle is rotated at the almost vertical position (if water is drained in ventilation status, water may splash. It is recommended to drain the water in gas cut-off status and use a container for drainage to prevent water from splashing onto the electrical plug underneath). After water drainage is completed, return the black handle at the bottom to the original position to prevent leakage (rotate to the horizontal level clockwise or counterclockwise). If cracks or leaks are found on the water trap or if the handle at the bottom cannot be rotated or has cracks, contact the service personnel.</p>
Before each use or after continuous use of two weeks	Perform system self-test. Check the breathing system resistance and leakage.
Check every half a year and replace every three years	Check the charging and discharging of the lithium battery every half a year and replace the lithium battery every three years.

Minimum frequency	Maintenance
Annually or as necessary	Calibrate the inspiration valve and expiratory flow sensor. Calibrate the pressure sensor and expiration valve. Calibrate the CO2 module. Check the check valves, including supply gas check valves, spontaneously inspiratory check valve, and expiratory check valve. Check the mechanical pressure relief valve. Check the supply gas seals. Check the alarm duration of the backup alarm system (buzzer).
Every six years or as necessary	Replace the battery of the clock module.
As necessary	Replace the O2 sensor if it is damaged (in typical use, the sensor performance meets the technical requirements at least within one year). Replace the expiratory flow sensor if it is damaged. Replace the expiration valve if it is damaged. Calibrate the touch screen if its function is degraded.

## 11.3 Pressure and Flow Zeroing

Zero pressure and flow when the monitored pressure or flow value has a great deviation. Zeroing can be performed in both standby and ventilation mode.

Follow these steps to zero pressure and flow:

1. Push the Menu key. Select [**Calibrate**] and select [**Zero**]. Select [**Paw and Flow Zero Cal.**] on the right side to start Paw and flow zeroing. The message [**Zeroing**] is displayed.
2. After a successful zeroing, the screen shows [**Zeroing Completed!**]. Otherwise, the message [**Zeroing Failure! Please try again.**] is displayed. In this case, you need to do the zeroing again.

---

## 11.4 Flow Sensor Calibration

### NOTE

---

- **Do not perform calibration while the unit is connected to a patient.**
  - **During calibration, do not operate the pneumatic parts. Do not move or press the breathing hoses especially.**
  - **Make sure that the system is Standby. If not, push the Standby key to enter standby screen.**
  - **It is recommended not to connect the humidifier to the ventilator before the calibration.**
- 

Calibrate the flow sensor when the measured value has a great deviation or when the flow sensor is replaced.

Follow these steps to calibrate the flow sensor:

1. Make sure that Air and O2 supplies are connected.
2. Connect the breathing hoses and insert the Y piece into the leak test plug to close the breathing circuit.
3. Push the Menu key. Select [**Calibrate**] and select [**Flow**]. Select [**Calibrate**] on the right side to start flow sensor calibration. The message [**Calibrating**] is displayed.
4. During the calibration, if you select [**Stop**], the ongoing calibration will stop and the message [**Calibration Stopped! Calibration is unfinished.**] is displayed.
5. After a successful calibration of both Air and O2 supplies, the screen shows [**Calibration Completed!**]. Otherwise, the message indicating calibration failure is displayed. In this case, you need to do the calibration again.

### NOTE

---

- **In case of calibration failure, check for sensor malfunctioning alarm and then troubleshoot it if there is. If it still fails or great measurement error occurs after calibration, replace the flow sensor and repeat the above operation. If the measurement error is still great, contact your service personnel or us.**
-

---

## 11.5 O2 Concentration Calibration

### NOTE

---

- **Do not perform O2 concentration calibration while the unit is connected to a patient.**
  - **Make sure that the system is Standby. If not, push the Standby key to enter standby screen.**
- 

Calibrate the O2 sensor when the measured O2 concentration has a great deviation or when the O2 sensor is replaced.

Follow these steps to calibrate the O2 sensor:

1. Make sure that Air and O2 supplies are connected.
2. Push the Menu key. Select [**Calibrate**] and select [**O2%**]. Select [**Calibrate**] on the right side to start O2 sensor calibration. The message [**Calibrating**] is displayed.
3. During the calibration, if you select [**Stop**], the ongoing calibration will stop and the message [**Calibration Stopped! Calibration is unfinished.**] is displayed.
4. After a successful calibration, the screen shows [**Calibration Completed!**]. Otherwise, the message [**Calibration Failure! Please try again.**] is displayed. In this case, you need to do the calibration again.

### NOTE

---

- **If the calibration fails, check for technical alarm and troubleshoot it if there is. Then do the calibration again. In case of repeated calibration failures, replace the O2 sensor and do the calibration again. If it still fails, contact your service personnel or us.**
  - **Handle and dispose of the O2 sensor according to your biohazard policies. Do not incinerate.**
-

---

## 11.6 CO2 Module Calibration

### NOTE

- 
- **Make sure that the system is Standby. If not, push the Standby key to enter standby screen.**
- 

Prepare the following before doing the calibration:

- Gas cylinder: cylinders filled with 3-7% CO2
- T-shape connector
- Sampling line

Follow these steps to perform CO2 calibration:

1. Check the airway and make sure that there are no occlusions or leaks. Make sure that the CO2 module is already warmed up or started.
2. Push the Menu key. Select [**Calibrate**] and then [**CO2**]. Select [**Zero**] on the right side.
3. After zeroing, connect the gas cylinder to the sampling line via a T-shape connector as shown below. Check the airway and make sure that there are no leaks.

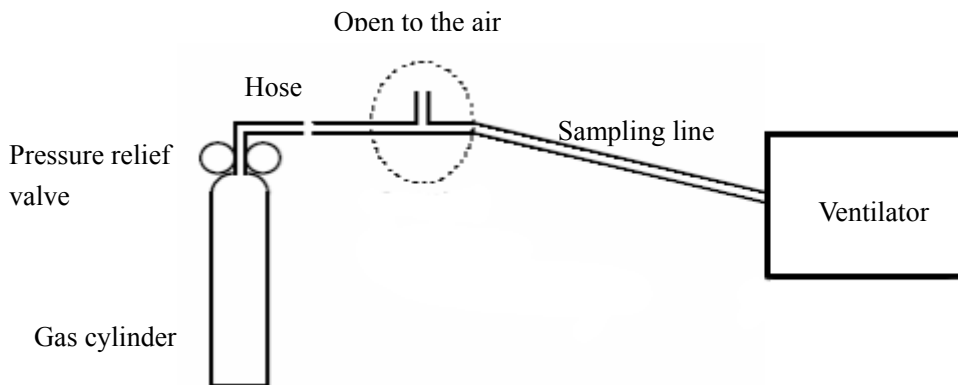

4. Vent the sampling line to the CO2 opening the cylinder pressure relief valve.
5. Input the vented CO2 concentration in the entry box.
6. The measured CO2 concentration is displayed. After the measured CO2 concentration becomes stable, select [**Calibrate**] to calibrate the CO2 module. The message [**CO2 Cal. Running**] is displayed.
7. After a successful calibration, the screen shows [**CO2 % Calibration Completed!**]. Otherwise, the message [**Calibration Failure! Please try again.**] is displayed. In this case, you need to do the calibration again.





---

## 11.7 Touch Screen Calibration

### NOTE

---

- **Make sure that the system is Standby. If not, push the Standby key to enter standby screen.**
- 
1. Push the Menu key. Select [**Calibrate**] and select [**Touchscreen**]. Select [**Calibrate**] on the right side.
  2. The  mark will appear in different locations of the screen.
  3. Click the central point of  one by one.
  4. After the calibration, the message [**Screen Calibration Completed!**] is displayed. Select [**Ok**] to complete calibration.

## 11.8 Battery Maintenance

### NOTE





---

- **Use batteries at least once every month to extend their life. Charge the batteries before they are depleted.**
  - **Inspect and replace batteries regularly. Battery life depends on how frequent and how long it is used. For a properly maintained and stored lithium battery, its life expectancy is approximately 3 years. For more aggressive use models, life expectancy can be shortened. We recommend replacing lithium batteries every 3 years.**
  - **In case of battery failure, contact us or have your service personnel replace it. Do not replace the battery without permission.**
- 

The ventilator is designed to operate on battery power whenever AC power becomes interrupted. When the ventilator is connected to the AC power source, the batteries are charged regardless of whether or not the ventilator is currently on. In case of power failure, the ventilator will automatically be powered by the internal batteries. When AC power source is restored within the specified time, power supply is switched from battery to AC automatically to ensure continuous system use.

---

On-screen battery icon indicates the battery statuses as follows:

- : indicates that AC power source is connected. The ventilator is powered by AC power source. The solid portion represents the current charge level of the batteries in proportion to its maximum charge level.
- : indicates that AC power source is not connected. The ventilator is powered by built-in batteries. The solid portion represents the current charge level of the batteries in proportion to its maximum charge level.
- : indicates that AC power source is not connected. The ventilator is powered by built-in batteries. The battery capacity is a bit low and the batteries need to be charged immediately.
- : indicates that no batteries are installed.

The capacity of the internal battery is limited. If the battery capacity is too low, power supply failure will occur and a high-level alarm [**Low Battery Voltage!**] will be triggered. In this case, apply AC power to the ventilator.

### 11.8.1 Battery Use Guidance

Inspect and replace batteries regularly. Battery life depends on how frequent and how long it is used. For a properly maintained and stored lithium battery, its life expectancy is approximately 3 years. For more aggressive use models, life expectancy can be shortened. We recommend replacing lithium batteries every 3 years.

To ensure maximum battery capacity:

- Check battery performance once every six months. Checking battery performance is also required before ventilator repair is carried out or when battery is doubted to be the source for ventilator failure.
- Condition batteries once every time when they have been used for three months or when the battery running time becomes noticeably shorter.

---

## 11.8.2 Battery Performance Conditioning

Condition batteries when they are put into use for the first time. A complete battery conditioning cycle is: uninterrupted charging, followed by uninterrupted discharging until the ventilator shuts off, and then uninterrupted charging. Condition batteries regularly to maintain their service life.

### NOTE

- 
- **Condition batteries every time when they have been used for three months or when the battery running time becomes noticeably shorter.**
  - **Over time and with the use of the battery, the actual battery capacity will decrease. For an old battery, the battery full icon does not indicate that the battery capacity or battery running time still meets the requirement specified. When conditioning batteries, replace the battery when its running time becomes noticeably shorter.**
- 

Follow these steps to condition batteries:

1. Disconnect the patient from the ventilator.
2. Connect the ventilator to the AC power source and charge the batteries uninterruptedly for at least 10 hours.
3. Disconnect the AC power source. Allow the ventilator to operate on battery power until the ventilator shuts off.
4. Re-connect the ventilator to the AC power source and charge the batteries uninterruptedly for at least 10 hours.
5. Battery conditioning is now completed.

## 11.8.3 Battery Performance Checking

Check battery performance once every six months. Checking battery performance is also required before ventilator repair is carried out or when battery is doubted to be the source for ventilator failure. Battery performance may degrade over time.

Follow these steps to check battery performance:

1. Disconnect the patient from the ventilator and shut down the ventilator.
2. Connect the ventilator to the AC power source and charge the batteries uninterruptedly for at least 10 hours.
3. Disconnect the AC power source. Allow the ventilator to operate on battery power until the ventilator shuts off.
4. The running time of the battery reflects its performance.

If the running time of the battery is noticeably shorter than that stated in the specifications, replace the battery or contact the service personnel.

---

## NOTE

---

- **If the running time of the battery is too short after fully charged, the battery may be damaged already or defective.**
  - **If obvious signs of damage are detected on the battery or the battery recharging is failed, replace the battery and recycle it properly.**
- 

### 11.8.4 Battery Recycling

If obvious signs of damage are detected on the battery or the battery recharging is failed, replace the battery and recycle it properly. Dispose of the battery in compliance with the local laws regulating the disposal of such product.

---

## WARNING

---

- **Do not disassemble batteries, dispose of them in fire, or short-circuit them. They may ignite, explode, leak, causing personal injury.**
- 

## 11.9 Electrical Safety Inspection

### NOTE

---

- **Perform electrical safety inspection after servicing or routine maintenance. Before the electrical safety inspection, make sure all the covers, panels, and screws are correctly installed.**
  - **The electrical safety inspection should be performed once a year.**
- 

### 11.9.1 Auxiliary Electrical Outlet Test

Verify the mains voltage is present at each auxiliary outlet when the ventilator is connected with power.

---

## 11.9.2 Electrical Safety Inspection Test

1. Perform protective earth resistance test:
  - a. Plug the probes of the analyzer into the protective earth terminal and equipotential terminal of the AC power cord.
  - b. Test the earth resistance with a current of 25 A.
  - c. Verify the resistance is less than 0.1ohms (100 mohms).
  - d. Plug the probes of the analyzer into the protective earth terminal of the AC power cord and the protective earth terminal of any auxiliary outlet. Repeat steps b and c.
  - e. If the resistance is larger than 0.1ohms (100 mohms) but less than 0.2ohms (200 mohms), disconnect the AC power cord and plug the probe that is previously plugged in the protective earth terminal of the AC power cord into the protective earth contact of the power outlet. Repeat steps a to d.
2. Connect the compressor, if configured, to the auxiliary electrical outlet.
3. Perform the following earth leakage current tests:
  - ◆ normal polarity;
  - ◆ reverse polarity;
  - ◆ normal polarity with open neutral; and
  - ◆ reverse polarity with open neutral.
4. Verify the maximum leakage current does not exceed 500  $\mu$ A (0.5 mA) in the first two tests. While for the last two tests, verify that the maximum leakage current does not exceed 1000  $\mu$ A (1 mA).

### NOTE

- 
- **Make sure the safety analyzer is authorized by certificate organizations (UL, CSA, or AMAI etc.). Follow the instructions of the analyzer manufacturer.**
  - **If cart is not configured, do not perform auxiliary outlet related tests, and the above mentioned AC power outlet should refer to the power outlet of the equipment.**
-

---

## 11.10 Water Build-up in the Flow Sensor

### 11.10.1 Prevent Water Build-up

The patient's exhaled warm and moist gas is condensed all the way when it flows along the expiratory hose. The condensed water remains on the hose wall and finally enters the water trap. When the patient's exhaled gas arrives at the expiration valve, it is not easily condensed in the expiration valve assembly since the heater is heating the expiration valve all the time. If the heater, however, malfunctions, or is not working efficiently, condensed water may also appear at the expiration valve and expiratory flow sensor, compromising the accuracy of measured values.

Check the expiratory flow sensor when abnormal flow waveform or unstable tidal volume fluctuation is detected. Check the sensor for water. If there is water build-up, clear it before use.

To prevent water build-up, solutions are:

1. Water condensation in the flow sensor can be eased using a filter between the expiratory hose and expiration valve.
2. Check the water trap for water during the use of the ventilator. If there is water build-up, clear it without delay.

### 11.10.2 Clear Water Build-up

The water built up inside the flow sensor will result in inaccurate measured values of tidal volume.

If there is water built up inside the flow sensor, remove the sensor and clear the water. Then reinstall the sensor for use.

---

#### **WARNING**

- **Check water build-up inside the flow sensor every time before system use. Pooled water in the flow sensor causes erroneous readings.**
  - **Make sure that all breathing system parts are dry every time when the breathing system is cleaned and disinfected.**
-

# 12 Accessories

---

---

---

## **WARNING**

---

- **Use only accessories specified in this chapter. Using other accessories may cause incorrect measured values or equipment malfunction.**
  - **Disposable accessories can not be reused. Reuse may degrade performance or cause cross-contamination.**
  - **Check the accessories and their packages for damage. Do not use them if any sign of damage is detected.**
  - **Parts which are intended to contact patients must comply with the biocompatibility requirement of ISO10993-1 to prevent any adverse reactions arising from such contact.**
  - **Disposal of the accessories shall comply with the applicable waste control regulations.**
  - **The reusable accessory kit can be disinfected for 50 times.**
  - **The humidifier shall be used with a ventilator to provide warm and humidified gases for patients.**
- 

## **Note**

---

- **All the accessories listed are validated for use with this specific ventilator. And the hospital is responsible for ensuring the compatibility of the ventilator and the accessories before use. The incompatible parts can result in degraded performance.**
-

Accessories			Description	PN	Manufacturer
Breathing tube kit	Reusable Breathing tube kit(adult) (115-00 4501-00)	tube	Silicone breathing tube, Adult, 600mm	082-000555-00	SAINT-GOBAIN
			Silicone breathing tube, Adult, 450mm	M6G-020039---	
		Y type connector	Reusable Y type connector (adult)	040-000735-00	VADI
		L type connector	Reusable L type connector	040-000736-00	VADI
		water trap	Reusable water trap(56ml)	040-000734-00	VADI
		straight connector	Reusable straight connector	040-000737-00	VADI
		extension tube	Extension tube (with connectors at both ends)	040-000738-00	VADI
	Reusable Breathing tube kit(child) (115-00 4502-00)	tube	Silicone breathing tube, Child, 600mm	082-000556-00	SAINT-GOBAIN
			Silicone breathing tube, Child, 450mm	082-000557-00	
		Y type connector	Reusable Y type connector (child)	040-000740-00	VADI
		straight connector	Reusable straight connector	040-000737-00	VADI
		L type connector	Reusable L type connector	040-000736-00	VADI
		water trap	Reusable water trap(30ml)	040-000739-00	VADI
		straight connector	Reusable straight connector	040-000741-00	VADI
	straight connector	Reusable straight connector	040-000742-00	VADI	
	Reusable Breathing tube kit(infant) (115-00 4503-00)	tube	Silicone breathing tube, infant, 600mm	082-000558-00	SAINT-GOBAIN
			Silicone breathing tube, infant, 450mm	082-000559-00	
		Y type connector	Reusable Y type connector (infant)	040-000743-00	VADI
		L type connector	Reusable L type connector	040-000736-00	VADI
		straight connector	Reusable straight connector	040-000737-00	VADI



Accessories			Description	PN	Manufacturer
		straight connector	Reusable straight connector	040-000742-00	VADI
		water trap	Reusable water trap(30ml)	040-000739-00	VADI
	Disposable Breathing tube kit		Disposable breathing tube (adult)	040-000755-00	Vincent medical
			Disposable breathing tube (child)	040-000756-00	
Filter			Disposable filter (round)	040-000757-00	Vincent medical
Nebulizer			Disposable jet nebulizer set	040-000799-00	VADI
Mask			New Sil-Flex Silicone Mask #5, Adult Large, 22F.	040-000818-00	GALEMED
			New Sil-Flex Silicone Mask #4, Adult, 22F.	040-000819-00	GALEMED
			New Sil-Flex Silicone Mask #3, Child Large, 22F.	040-000820-00	GALEMED
			Sil-Flex Silicone Face Mask #2, Child	040-000821-00	GALEMED
			Inflatable anesthesia mask (Adult Large)	M6Q-150013---	GALEMED
			Inflatable anesthesia mask (Adult)	M6Q-150012---	GALEMED
			Inflatable anesthesia mask (Child Large)	M6Q-150011---	GALEMED
			Inflatable anesthesia mask (Child)	M6Q-150010---	GALEMED
			Inflatable anesthesia mask (infant Large)	M6Q-150009---	GALEMED
			Inflatable anesthesia mask (infant)	040-000759-00	GALEMED
Head Harness			Silicone head harness (adult)	040-000760-00	GALEMED
			Silicone head harness (child)	040-000761-00	GALEMED
			Silicone head harness (infant)	040-000762-00	GALEMED
Test lung			Clipped Test Lung (adult)	040-000744-00	VADI
			Test Lung (infant)	040-000745-00	VADI

Accessories		Description	PN	Manufacturer
Humidifier		Humidifier(VADI/230V/adult humidification chamber)	115-004505-00	VADI
		Humidifier(VADI/230V/adult auto-feeding chamber)	115-004506-00	VADI
		Humidifier(VADI/230V/pediatric humidification chamber)	115-004507-00	VADI
		Humidifier(VADI/115V/adult humidification chamber)	115-004508-00	VADI
		Humidifier(VADI/115V/adult auto-feeding chamber)	115-004509-00	VADI
		Humidifier(VADI/115V/pediatric humidification chamber)	115-004510-00	VADI
		Humidifier(MR850/230V/adult/heating/tube)	115-004511-00	Fisher&Paykel
		Humidifier(MR850/115V/adult/heating/tube)	115-004513-00	Fisher&Paykel
		Humidifier(MR810/230V/adult /tube)	115-004515-00	Fisher&Paykel
		Humidifier(MR810/115V/adult /tube)	115-004516-00	Fisher&Paykel
Gas supply tube assembly(O2, Air)		Air tube assembly	115-008200-00	AMVEX
		O2 tube assembly	115-008201-00	AMVEX
Oxygen sensor		Oxygen sensor	040-000708-00	CITY
CO2 module accessories <sup>1</sup>	sample line	Sampling Line, Adult 2.5m (Adult/pediatric, Disposable)	9200-10-10533	Artema Medical
	Water trap	DRYLINE Watertrap (Adult/pediatric, Reusable)	9200-10-10530	Artema Medical
	Airway adapter	DRYLINE Airway Adapter (Straight, Adult/pediatric, Disposable)	9000-10-07486	Artema Medical

<sup>1</sup> Note: The CO2 module accessory material that contacts the patients has undertaken the bio-compatibility test and is verified to be in compliance with ISO 10993-1.

# A Theory of Operation

## A.1 Pneumatic System

### A.1.1 Pneumatic Circuit Diagram

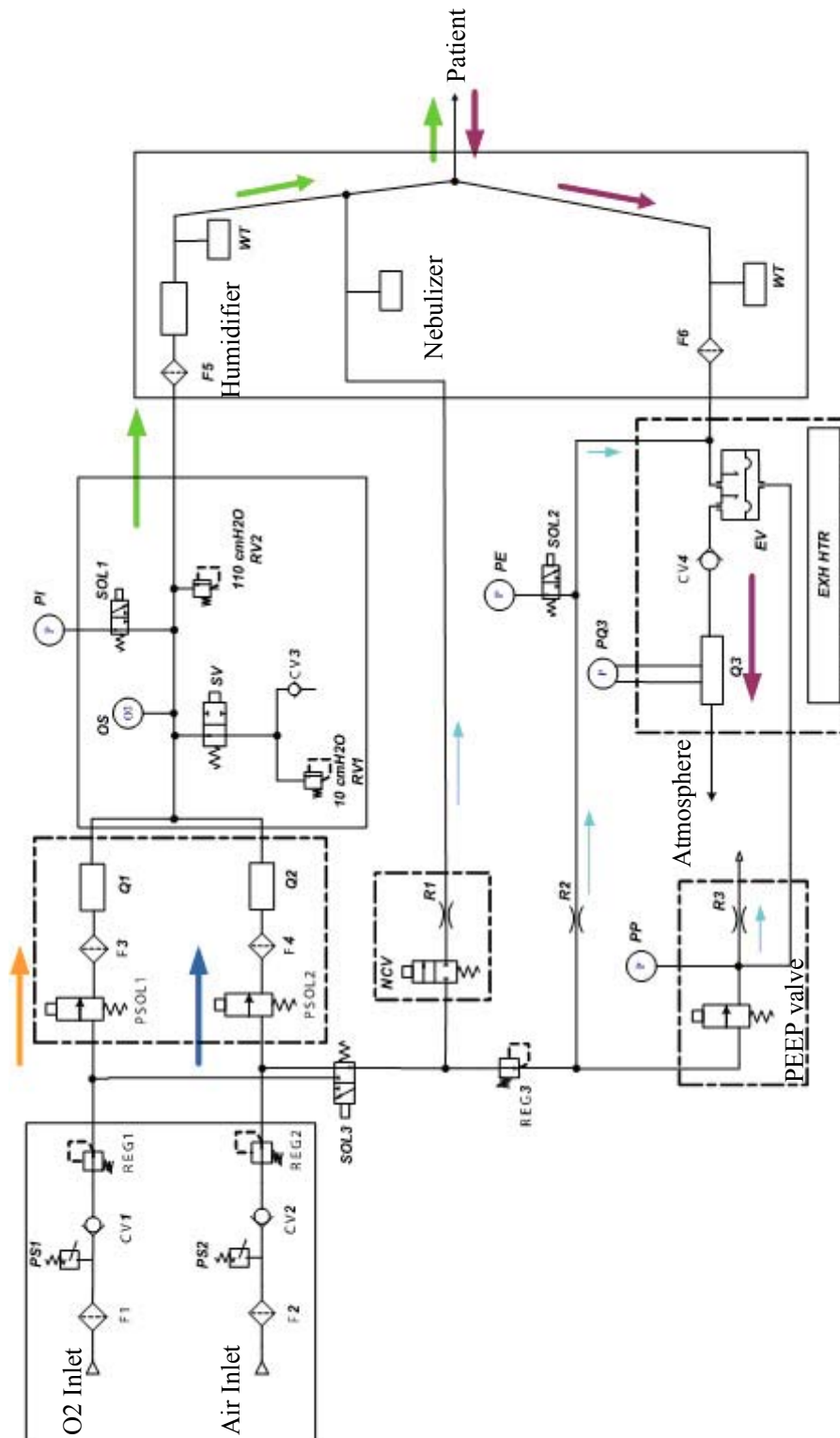

## A.1.2 Parts List

Symbol	Description	Symbol	Description
F1/F2	Filter at supply gas inlet (O2/Air)	SOL2	Three-way valve for expiratory pressure zeroing
PS1/PS2	Pressure switch for supply gas pressure monitoring (O2/Air)	PE	Expiratory pressure sensor
CV1/CV2	Check valve at supply gas inlet (O2/Air)	EV	Expiration valve
REG1/REG2	Regulator (O2/Air)	CV4	Expiratory check valve
PSOL1/PSOL2	Proportional solenoid valve (O2/Air)	EXH HTR	Expiratory heater
F3/F4	Dust filter (O2/Air)	Q3	Expiratory flow sensor
Q1	O2 flow sensor	PQ3	Differential pressure sensor
Q2	Air flow sensor	SOL3	Three-way valve for Air/O2 connection selection
OS	O2 sensor	NCV	Nebulizer control valve
SV	Inspiratory safety valve	Nebulizer	Nebulizer (legally launched)
RV1	Pressure relief valve (10 cmH2O)	REG3	Regulator
CV3	Check valve at spontaneously inspiratory port	R1	Resistor
RV2	Pressure relief valve (110 cmH2O)	R2	Resistor
SOL1	Three-way valve for inspiratory pressure zeroing	PEEP valve	PEEP valve
PI	Inspiratory pressure sensor	R3	Resistor
WT	Water trap	PP	PEEP pressure
F5/F6	Inspiratory/expiratory filter	Humidifier	Humidifier

Note: the nebulizer mentioned in this manual shall be the legal product with medical device certificate registered in the People's Republic of China. This requirement applies to nebulizer mentioned in other place than here.

---

### A.1.3 Description

This product is pneumatically driven, microprocessor controlled ventilator. As the integration of electronics, pneumatics, mechanics, software and other subjects, the ventilator can partially or fully replace the ventilation function of the patient. During the inspiratory phase, the inspiration valve opens. High pressure Air and O<sub>2</sub> supplies enter the ventilator, pass through an Air and O<sub>2</sub> mixer, and become fresh gas with specific concentration of O<sub>2</sub>, and specific flow or pressure. The fresh gas enters the patient's lungs through hose. During the expiratory phase, the inspiration valve is closed while the expiration valve opens. The gas is expired by the patient's efforts.

The O<sub>2</sub> and Air supply connectors are designed as required by the relevant standard to prevent from wrong connection. Filter (F1/F2) filters the water, oil, and other foreign substance in the supplied gas. Pressure switch (PS1/PS2) monitors the pressure of supply gas and gives an alarm in case of low supply gas pressure. Check valve (CV1/CV2) ensures unidirectional gas flow. Regulator (REG1/REG2) reduces and stabilizes the pressure of supply gas to ensure that the inspiratory proportional valve at the rear end outputs stable and repeatable flow.

Proportional solenoid valve PSOL1/ PSOL2() is controlled by drive current. Different drive currents correspond to different flows of solenoid valve so as to achieve accurate control of inspiratory flow. Dust filter (F3/F4) is placed before flow sensor to stabilize gas flow, facilitating measurement by sensor. Flow sensor (Q1/Q2) is hot-wire flow sensor for accurate measurement of gas passing through and does not require calibration.

After flowing through the flow control subsystem, O<sub>2</sub> and Air are mixed in the gas mixing system. Make sure that O<sub>2</sub> and Air are evenly mixed before flowing through O<sub>2</sub> sensor (OS). Otherwise, the measured value by the O<sub>2</sub> sensor is not consistent with the actual O<sub>2</sub> concentration. Inspiratory safety valve (SV) is controlled by electromagnet. When the ventilator works normally, the electromagnet is powered on and the safety valve is closed. When the pressure in the inspiratory path exceeds the preset pressure, the electromagnet is powered off, the safety valve opens, and the gas is released through pressure relief valve (RV1). When the system is powered off, all electronically controlled components inside the ventilator cannot work. In this case, the electromagnet is in power-off status and the safety valve opens. The patient inspires the ambient air through the spontaneously inspiratory path.

Check valve (CV3) ensures the unidirectional gas flow and prevents repeated breathing during the patient's spontaneous inspiration. Inspiratory pressure sensor (PI) monitors the pressure in the inspiratory path. Zeroing three-way valve (SOL1) zeroes the inspiratory pressure sensor periodically. RV2 is mechanical pressure relief valve. It releases pressure when the pressure exceeds  $110 \pm 10$ cmH<sub>2</sub>O. RV2 opens to release pressure when the airway pressure reaches the release pressure to ensure the patient safety.

---

Nebulizer control valve (NCV) is a two-way solenoid valve which has two statuses: connected and disconnected. Resistor (R1) is an orifice. When NCV is connected, continuous flow of 6 to 9 L/min is produced. Such flow enters the nebulizer through the connector on the front panel of the ventilator. The nebulizer aerosolizes medication which enters the respiratory tract with the inspiration of the patient.

The fresh gas produced by the ventilator is delivered to the patient's lungs through patient hose.

Expiration valve (EV) is pneumatically controlled. The expiration valve closing pressure is controlled by PEEP valve and R3. When the control current given by the system to PEEP valve is zero, the expiration valve is fully open. When the system gives some control current to the PEEP valve, PEEP produces some flow, which produces pressure together with R3 to push the expiration valve diaphragm to close the valve port. The patient's expired gas must overcome the valve closing pressure to go through the valve port. This dynamic process finally ensures that the preset pressure goes throughout the patient's inspiration and expiration processes. Expiratory pressure sensor (PE) monitors the expiration valve closing pressure.

Regulator (REG3) at the front end of PEEP is used to stabilize pressure to prevent change of valve closing pressure caused by change of PEEP front end pressure. SOL3 is a three-way valve for Air/O<sub>2</sub> connection selection. Air is preferred for expiration valve control gas. When Air is not available or Air pressure is relatively low, O<sub>2</sub> is selected to ensure that expiration valve pressure can be controlled.

During the inspiratory phase, the system gives control current to the PEEP valve to close the valve at a certain pressure level, so as to ensure that the delivered Air and O<sub>2</sub> mixed gas from the ventilator goes first into the patient. If an accident happens during the mixed gas delivery process which causes the delivered gas pressure to be greater than the limit pressure, excess pressure is released from the expiration valve to ensure the patient safety.

During the expiratory phase, the system gives zero control current or relatively small control current to the PEEP valve, which indicates that the expiration valve is fully open or produces a certain valve closing pressure. When the expiration valve is fully open, it is equivalent to the situation that the patient's expired gas is directly open to the air (same to the expiration of a normal person). When the expiration valve has some valve closing pressure (PEEP), it is equivalent to the situation that the patient's expired gas is always kept at a positive pressure, which is clinically significant.

---

Check valve (CV4) ensures the unidirectional gas flow. When the patient inspires spontaneously, gas goes from the ambient air, through check valve (CV3) of the inspiratory safety module, patient hose, and into the patient's respiratory tract. At this point, CV4 is closed. When the patient expires spontaneously, gas flows out of the patient's respiratory tract, through the patient hose, expiration valve, CV4, expiratory flow sensor, and into the ambient air. CV4 opens. At this point, CV4 is open while CV3 is closed. It can be seen from this process that the co-effort made by CV3 and CV4 ensures the unidirectional gas flow during the patient's spontaneous breathing and prevents repeated breathing.

Expiratory heater (EXH HTR) is a heating device which heats the expiration valve, check valve, and expiratory flow sensor to prevent the expired gas from condensation which compromises the measurement accuracy.

Expiratory flow sensor (Q3) is a flow sensor based on the principle of differential pressure. Diaphragm-type sensor is characterized by high sensitivity and low requirement for electric circuit. After long term of use, however, the diaphragm will be distorted. Therefore, periodical user calibration is necessary to ensure measurement accuracy. When the gas passes through the expiratory flow sensor, differential pressure is produced on both sides of the diaphragm. Flow information is acquired based on the differential pressure after collected and processed by differential pressure sensor (PQ3).

Expiratory pressure sensor (PE) measures the expiratory pressure. SOL2 is a zeroing three-way valve. Small flow is formed at the rear end of R2 and flows into the expiratory circuit continuously, for the purpose of flushing the pressure sampling line so as to prevent water from condensing in the sampling line, which compromises pressure measurement accuracy.

---

## A.2 Electrical System

### A.2.1 Electrical Block Diagram

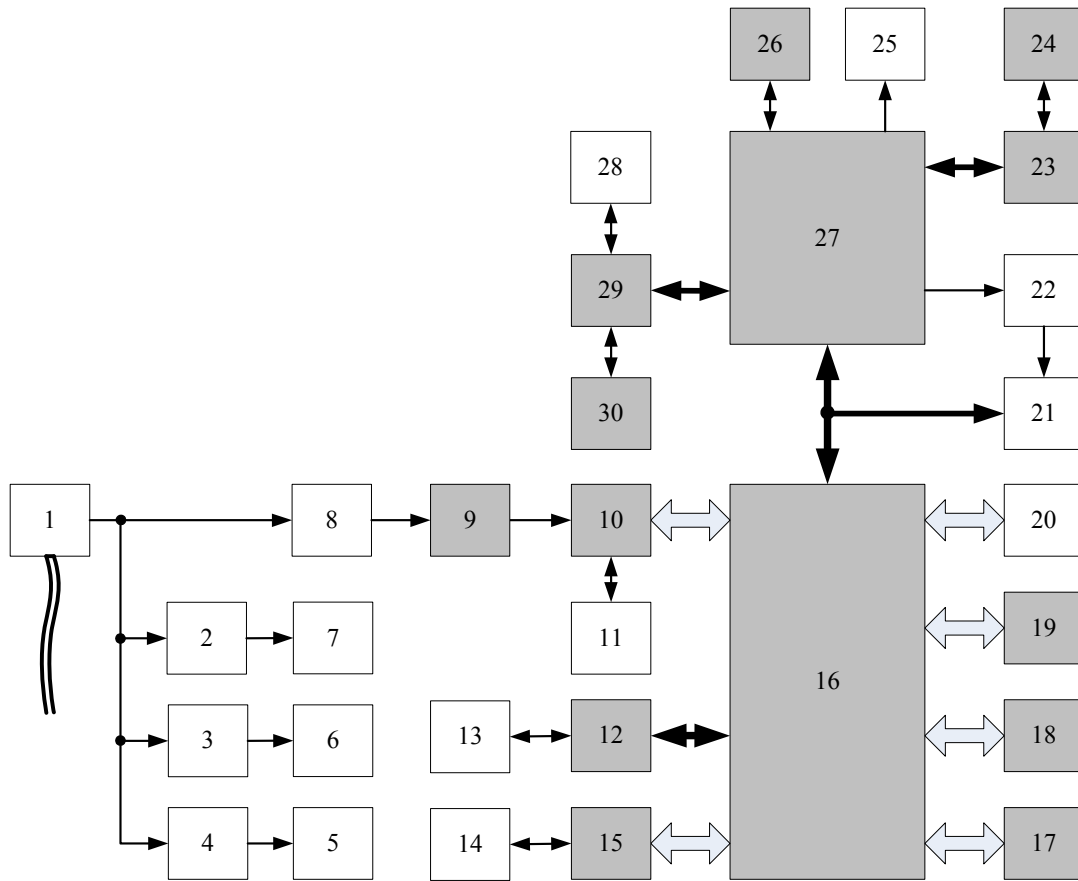



---

## A.2.2 Parts List

1	AC mains input and fuse	16	Motherboard
2	Auxiliary electrical outlet fuse 1	17	Monitor board
3	Auxiliary electrical outlet fuse 2	18	Expand board
4	Auxiliary electrical outlet fuse 3	19	Main control board
5	Auxiliary electrical outlet 3	20	Lithium battery (two packs)
6	Auxiliary electrical outlet 2	21	LCD
7	Auxiliary electrical outlet 1	22	Inverter
8	Main unit AC power socket and fuse	23	Key scan board (right)
9	AC-DC power board	24	Rotary encoder
10	DC-DC power board	25	Speaker
11	Fan	26	Alarm lamp board
12	Inspiratory module board	27	Key control board
13	O2 flow sensor/Air flow sensor/pressure sensor/O2 concentration sensor etc. and O2 valve/Air valve/safety valve etc.	28	Touchscreen
14	Expiratory flow sensor/pressure sensor/hot-wire temperature sensor etc., and expiration valve/heating plate etc.	29	Key scan board (left)
15	Expiratory module board	30	Power switch board

---

**FOR YOUR NOTES**

# B Product Specifications

---

The ventilator is already integrated with expiratory volume monitor, pressure measurement device, and pressure release device. It has a built-in gas mixer and is equipped with alarm system, O<sub>2</sub> monitor, and CO<sub>2</sub> monitor, where:

- The expiratory volume monitor, pressure measurement device, and pressure release device comply with IEC60601-2-12 .
- The expiratory volume monitor, pressure measurement device, and pressure release device comply with IEC80601-2-12.
- The built-in gas mixer complies with ISO11195.
- The alarm system complies IEC 60601-1-8.
- The O<sub>2</sub> monitor complies with ISO21647.
- The CO<sub>2</sub> monitor complies with ISO21647.
- The O<sub>2</sub> monitor complies with IEC80601-2-55.
- The CO<sub>2</sub> monitor complies with IEC80601-2-55.

## B.1 Safety Specifications

Type of protection against electric shock	Class I equipment with internal electrical power supply. Where the integrity of the external protective earth (ground) in the installation or its conductors is in doubt, the equipment shall be operated from its internal electrical power supply (batteries).
Degree of protection against electric shock	BF, defibrillation-proof
Operating mode	Continuous
Degree of protection against hazards of explosion	Ordinary equipment, without protection against explosion; not for use with flammable anaesthetics.
Degree of protection against harmful ingress of water	Degrees of protection provided by enclosures(IP Code)—IP21 Protection Index according the EN 60529 standard: <b>2:</b> Protected against solid foreign objects of 12.5 mm diameter and greater <b>1:</b> Protected against vertically falling water drops
Electrical connections between the equipment and the patient	Non-electrical connections
Equipment type	Mobile
Disinfection	Steam autoclavable or other disinfection method.

## B.2 Environmental Specifications

Main unit			
Item	Temperature (°C)	Relative humidity (non-condensing)	Barometric pressure (kPa)
Operating	+10 to +40	15 to 95%	50 to 106
Storage and transport	-20 to +60 (O2 sensor: -20 to +50)	10 to 95%	50 to 106

## B.3 Power Requirements

External AC power supply		
Input voltage	220 to 240 V	100 to 120 V
Input frequency	50/60 Hz	50/60 Hz
Input current	10A	15A
Fuse	T10AH/250V	T15AH/250V
Main unit power supply		
Input voltage	100 to 240 V	
Input frequency	50/60 Hz	
Input current	1.6 to 0.8A	
Fuse	T3.15AH/250V	
Auxiliary output power supply		
Output voltage	220 to 240 V	100 to 120 V
Output frequency	50/60 Hz	50/60 Hz
Output current (outlet 1)	3.0A	6.0A
Output current (outlet 2)	3.0A	3.5A
Output current (outlet 3)	3.0A	3.5A
Fuse (outlet 1)	T5AH/250V	T10AH/250V
Fuse (outlet 2)	T5AH/250V	T5AH/250V
Fuse (outlet 3)	T5AH/250V	T5AH/250V
Internal battery		
Number of batteries	One or two	
Battery type	Lithium-ion battery	
Rated battery voltage	11.1 VDC	
Battery capacity	4500 mAh for a single battery	
Overcurrent protection	8±2A	
Time to shutdown	10 min at least (powered by new fully-charged batteries after the first low battery alarm)	
Battery run time	90 min (powered by one new fully-charged battery at 25°C ambient temperature); 180 min (powered by two new fully-charged batteries at 25°C ambient temperature).	

## B.4 Physical Specifications

<b>System noise</b>	
System noise	A-weighted sound pressure level ( $L_{pA}$ ) $\leq 45$ dB(A) A-weighted sound power level ( $L_{WA}$ ) $\leq 53$ dB (A)
<b>Main unit</b>	
Dimensions	470 x 430 x 500 mm (height x width x depth) (excluding CO <sub>2</sub> module) 1340 x 560 x 730 mm (height x width x depth) (excluding hoses)
Weight	Approximately 25 kg (excluding CO <sub>2</sub> module ) Approximately 45 kg (excluding hoses)
<b>Caster</b>	
Caster	4 casters with diameter not less than 100 mm. At least two front casters have brakes.
<b>Display</b>	
Type	Color active matrix TFT LCD
Size	12.1"
Resolution	800 x 600 pixels
Brightness	Adjustable
Touch screen	Available, anti-glare
<b>LED indicator</b>	
Alarm LED	One (yellow and red. When high and medium level alarms occur simultaneously, it flashes red only)
AC power LED	One (green; lit when connected to the AC power supply)
Battery LED	One (green; lit when batteries are installed and AC power supply is connected; flashing when powered by batteries; extinguished when no batteries are installed or AC power supply is not connected.)
Operating status LED	One (green; lit when powered on and extinguished when powered off)
<b>Audio indicator</b>	
Speaker	Gives off alarm tones and key tones; supports multi-level tone modulation. The alarm tones comply with the requirements of IEC60601-1-8.
Buzzer	Gives off auxiliary audio alarm in case of speaker malfunction.
<b>Connector</b>	
Network connector	One multiplex connector supporting network and software online upgrade.
RS-232 connector	Connects to medical-grade external device via RS-232 protocol to implement the communication between the ventilator and external device.

CO <sub>2</sub> /calibration connector	One multiplex connector for calibrating inspiratory and expiratory flows and supplying power for the external CO <sub>2</sub> analyzer.
Nurse call connector	Provides digital signals to drive the hospital's nurse call system.
VGA connector	Outputs VGA video signals with the same contents to the primary display and connects to the external display.

## B.5 Pneumatic System Specifications

Supply gas	
Gas type	Air and O <sub>2</sub>
Pipeline pressure range	280 to 650 kPa
Rated flow	40 to 160 l/min STPD
Pipeline connector	NIST or DISS
Filter	5 µm of aperture
Requirements for supply gas	The supplied gas must not contain water, oil or foreign substance whose content must be under the following standards: Air: H <sub>2</sub> O<7g/m <sup>3</sup> , oil <0.5g/m <sup>3</sup> O <sub>2</sub> : H <sub>2</sub> O<20g/m <sup>3</sup> Dew point of the compressed air: lower than room temperature by 5°C in case of 30 L/min flow
Fresh gas	Fresh gas is called after supplied Air and O <sub>2</sub> are mixed.
Inspiration mode	
Peak flow in case of single supply gas	>180 L/min
Pneumatic medicament nebulizer connector	Synchronous with inspiration at 6 to 9 L/min flow
Safety valve release pressure	<125 cmH <sub>2</sub> O
External connector at the inspiratory port	Coaxial 22 mm/15 mm conical connector
Expiration module	
External connector at the expiratory port	Coaxial 22 mm/15 mm conical connector
System compliance and resistance	
Compliance	Not greater than 2 mL/cmH <sub>2</sub> O
Inspiratory resistance	Not greater than 6 cm H <sub>2</sub> O at 60 L/min flow (adult reusable breathing hose ) Not greater than 6 cmH <sub>2</sub> O at 30 L/min flow (pediatric reusable breathing hose ) Not greater than 6 cmH <sub>2</sub> O at 5 L/min flow (infant reusable breathing hose)

Expiratory resistance	Not greater than 6 cmH <sub>2</sub> O at 60 L/min flow (adult reusable breathing hose ) Not greater than 6 cmH <sub>2</sub> O at 30 L/min flow (pediatric reusable breathing hose ) Not greater than 6 cmH <sub>2</sub> O at 5 L/min flow (infant reusable breathing hose)
Bacterial filter	Resistance: < 2 cmH <sub>2</sub> O at 60 l/min Particle size: Captures particles of 0.3 mm (micron) with > 99.99% efficiency Dead space: < 80 mL
<b>Leakage</b>	
Leakage	Not greater than 200mL/min@50cmH <sub>2</sub> O Not greater than 100mL/min@40cmH <sub>2</sub> O Not greater than 50mL/min@20cmH <sub>2</sub> O

## B.6 Ventilator Specifications

<b>Controlled parameters</b>			
<b>Parameter</b>	<b>Range</b>	<b>Step</b>	<b>Unit</b>
O <sub>2</sub> %	21 to 100	1	%
TV	Pediatric: 20 to 300 Adult: 100 to 2000	Pediatric: 1 Adult: 10	mL
f	Pediatric: 1 to 150 Adult: 1 to 150	1	bpm
fSIMV	1 to 60	1	bpm
T <sub>insp</sub> 0.2	0 to 10	0.05	s
I:E	4:1 to 1:10	0.5	/
Flow <sup>1</sup>	Pediatric: 6 to 30 Adult: 6 to 120	1 L/	min
Maximum flow <sup>2</sup>	180	/	L/min
T <sub>slope</sub>	0 to 2.00	0.05	s
P <sub>limit</sub>	5 to 105	1	cmH <sub>2</sub> O
PEEP	OFF, 1 to 45	1	cmH <sub>2</sub> O
P <sub>insp</sub>	5 to 100	1	cmH <sub>2</sub> O
△P <sub>supp</sub>	0 to 100	1	cmH <sub>2</sub> O
P <sub>high</sub>	0 to 100	1	cmH <sub>2</sub> O

<sup>1</sup> Note: It refers to the inspiratory flow which can be set for Volume Control modes.

<sup>2</sup> Note: It refers to the maximum inspiratory flow for Pressure Control and Pressure Support Ventilation modes.

Plow	0 to 50	1	cmH <sub>2</sub> O
Thigh	0.2 to 30	0.1	s
Tlow	0.2 to 30	0.1	s
Trigger	0.5 to 15	0.1	L/min
	-10 to -0.5	0.5	cmH <sub>2</sub> O
△int.PEEP	OFF, 1 to 40	1	cmH <sub>2</sub> O
Exp%	Auto, 10 to 85	5	%
△Papnea	Provides pressure apnea setting. Refer to PInsp specification.		
fapnea	Pediatric: 1 to 100 Adult: 1 to 100	1	bpm
<b>Weight</b>			
Pediatric	3 to 35	0.5	kg
Adult	10 to 200	1	kg
<b>Monitored parameters</b>			
<b>Parameter</b>	<b>Range</b>	<b>Resolution</b>	<b>Unit</b>
Ppeak	-20 to +120	1	cmH <sub>2</sub> O
Pplat			
Pmean			
PEEP	0 to 120	1	cmH <sub>2</sub> O
TVi	0 to 4000	1	mL
TVe			
TVe spn			
MV	0 to 100	0.1	L/min
MVspn			
MVleak			
ftot	0 to 200	1	bpm
fmand			
fspn			
Rinsp	0 to 600	1	cmH <sub>2</sub> O/(L/s)
Rexp	0 to 600	1	cmH <sub>2</sub> O/(L/s)
Cstat	0 to 300	1	mL/cm H <sub>2</sub> O
Cdyn	0 to 300	1	mL/cm H <sub>2</sub> O
RSBI	0 to 9999	1	1/(min·L)
WOB	0 to 100	1	J/min
NIF	-45 to 0	1	cmH <sub>2</sub> O



P0.1	-20 to 0	0.1	cmH <sub>2</sub> O
PEEPi	0 to 120	0.1	cmH <sub>2</sub> O
FiO <sub>2</sub>	15 to 100	1	%

## B.7 Ventilator Accuracy

Control accuracy	
O <sub>2</sub> %	±3 vol.% or ±5% of setting, whichever is greater
TV	±10 mL or ±10% of setting, whichever is greater
f	1 bpm to 100 bpm: ±1 bpm Other range: ±2% of setting
fSIMV	±1 bpm
T <sub>insp</sub>	±0.1s or ±10% of setting, whichever is greater
I: E	2: 1 to 1: 4: ±10% of setting Other range: not defined.
Flow	±1 L/min or ±20% of setting, whichever is greater
T <sub>slope</sub>	±0.2s
Plimit	±2.0 cmH <sub>2</sub> O or ±10% of setting, whichever is greater
PEEP	±2.0 cmH <sub>2</sub> O or ±10% of setting, whichever is greater
P <sub>insp</sub>	±2.0 cmH <sub>2</sub> O or ±10% of setting, whichever is greater
△P <sub>supp</sub>	±2.0 cmH <sub>2</sub> O or ±10% of setting, whichever is greater
P <sub>high</sub>	±2.0 cmH <sub>2</sub> O or ±10% of setting, whichever is greater
P <sub>low</sub>	±2.0 cmH <sub>2</sub> O or ±10% of setting, whichever is greater
T <sub>high</sub>	±0.2s or ±10% of setting, whichever is greater
T <sub>low</sub>	±0.2s or ±10% of setting, whichever is greater
Trigger	±1.0 cmH <sub>2</sub> O or ±10% of setting, whichever is greater or, ±1.0 L/min or ±20% of setting, whichever is greater
△int.PEEP	±2.0 cmH <sub>2</sub> O or ±20% of reading whichever is greater
Exp%	±10%
f <sub>apnea</sub>	±1 bpm
△P <sub>apnea</sub>	±2.0 cmH <sub>2</sub> O or ±10% of setting, whichever is greater
Monitoring accuracy	
P <sub>peak</sub>	±(2 cmH <sub>2</sub> O + 4 % of the actual reading)
P <sub>plat</sub>	
P <sub>mean</sub>	
PEEP	

TVi	0 ml~100 ml: $\pm (10 \text{ ml} + 3\% \text{ of reading})$
TVe	100 ml~4000 ml: $\pm (5 \text{ ml} + 8\% \text{ of reading})$
TVe spn	$\pm 15\%$ of reading or $\pm 15 \text{ mL}$ , whichever is greater (NIV)
MV	$\pm 8\%$ of reading or $\pm 0.3 \text{ L/min}$ , whichever is greater
MVspn	
MVleak	
ftot	$\pm 5\%$ of reading or $\pm 1 \text{ bpm}$ , whichever is greater
fmand	
fspn	
Rinsp	0 to 50: $\pm 10 \text{ cmH}_2\text{O}/(\text{L/s})$
Rexp	Other range: not defined.
Cstat	0 to 100: $\pm 10 \text{ mL}/\text{cmH}_2\text{O}$ or $\pm 20\%$ of the displayed value, whichever is greater
Cdyn	
RSBI	0 to 1000: $\pm 20 \text{ 1}/(\text{min}\cdot\text{L})$ or $\pm 15\%$ of the displayed value, whichever is greater Other range: not defined.
WOB	No declaration
NIF	$\pm (2 \text{ cmH}_2\text{O} + 4\% \text{ of the actual reading})$
P0.1	$\pm (2 \text{ cmH}_2\text{O} + 4\% \text{ of the actual reading})$
PEEPi	No declaration
FiO <sub>2</sub>	21% to 100%: $\pm 3 \text{ vol.}\%$ ; Other range: not defined.
Oxygen concentration controlling responded time	the responded time of the oxygen concentration in the delivered volume to change from a volume fraction of 21 % to 90 %: when reusable adult pipeline is used, TV=500ml, f=10bpm, I:E=1:2, $\leq 40 \text{ s}$ ; when reusable pediatric pipeline is used, TV=150ml, f=20bpm, I:E=1:2, $\leq 60 \text{ s}$ ; when reusable infant pipeline is used, TV=30ml, f=30bpm, I:E=1:2, $\leq 40 \text{ s}$ .

## B.8 Alarms

### B.8.1 Settable Alarms

Alarm settings				
Parameter		Setting range	Automatic threshold	Notes
TV	High limit	110 to 4000 mL, OFF(Adult) 25 to 4000 mL, OFF(Pediatric)	$1.5 \times \text{TVE average value}$	High limit is greater than low limit.
MV	High limit	Pediatric: 0.2 to 60.0 L/min (non-NIV) Adult: 0.2 to 100.0 L/min (non-NIV) Pediatric: 0.1 to 60.0 L/min (NIV) Adult: 0.1 to 100.0 L/min (NIV)	$1.5 \times \text{MV monitored value}$	
	Low limit	Pediatric: 0.1 to 30.0 L/min (non-NIV) Adult: 0.1 to 50.0 L/min (non-NIV) Pediatric: 0.1 to 30.0 L/min, OFF (NIV) Adult: 0.1 to 50.0 L/min, OFF (NIV)	$0.5 \times \text{MV monitored value}$	
Paw	High limit	10 to 105 cmH <sub>2</sub> O	Average peak pressure+10cmH <sub>2</sub> O and 35cmH <sub>2</sub> O, whichever is greater	
ftot	High limit	1 to 160, OFF	$1.4 \times \text{ftot monitored value}$	
Tapnea		5 to 60s	15	/

### B.8.2 Auto Alarms

Parameter		Alarming condition
Paw	Low limit	Internally set alarm limit: PEEP+4 cmH <sub>2</sub> O
FiO <sub>2</sub>	High limit	FiO <sub>2</sub> exceeds the alarm limit for at least 20s. Internally set alarm limit: Set value + max (7% or set value x 10%).
	Low limit	FiO <sub>2</sub> is lower than the alarm limit for at least 20s. Internally set alarm limit: set value - max (7% or set value x 10%). Absolute FiO <sub>2</sub> low limit: 18% O <sub>2</sub>
Sustained Pressure	Airway	Internally set alarm limit: PEEP+15 cmH <sub>2</sub> O The alarm limit is exceeded for 15s continuously.

## B.9 Special Functions

Function	Specification
Inspiration Hold	Push and hold the Insp. Hold key to activate this function. Inspiration Hold is active for a maximum of 30s.
Expiration Hold	Push and hold the Exp. Hold key to activate this function. Expiration Hold is active for a maximum of 30s.
O2 ↑	O2 ↑ is delivered for a fixed 2 min. During O2 ↑, O2 concentration for adult patients is 100% and that for pediatric patients is 1.25 times of the currently set O2 concentration or 100%, whichever is less.
Suction	Phase 1: O2 ↑ before suction. Delivering 100% O2 lasts for a maximum of 120 s. O2 concentration for adult patients is 100% and that for pediatric patients is 1.25 times of the currently set O2 concentration or 100%, whichever is less. When patient disconnection is detected, the system enters next phase automatically. Phase 2: suction. Suction lasts for a maximum of 120s. When patient reconnection is detected, the system enters next phase automatically. Phase 3: O2 ↑ after suction. Delivering 100% O2 lasts for a maximum of 120s. O2 concentration for adult patients is 100% and that for pediatric patients is 1.25 times of the currently set O2 concentration or 100%, whichever is less.
Nebulizer	Supports jet nebulizer; Supports to set nebulizer time ranging from 1 to 60 min.
Manual Breath	One breath is delivered in the expiratory stage. Manual breath is not responded if delivered in the inspiratory stage or when the expiratory stage is not finished.
Sigh	Sigh is started once every three minutes in V-A/C. Sigh started within two continuous ventilation cycles is effective.
Volume sigh	A sigh is delivered every 100 breaths or 7 minutes (whichever is earlier) in V-A/C mode. Tidal volume of 1.5 times of the set value is delivered every 100 breaths.
Screen Locking	Prevents ventilator settings and values displayed from being changed due to inadvertent key clicking.

## B.10 CO<sub>2</sub> Module Specifications

CO <sub>2</sub> module		
Measurement range and accuracy	Measurement range	Accuracy
	0 to 40 mmHg	±2 mmHg
	41 to 76 mmHg	±5% of reading
	77 to 99 mmHg	±10% of reading
Resolution	1 mmHg	
Rise time	<330ms@100mL/min <400ms@70mL/min	
Delay time	<3s@100mL/min <3.5s@70mL/min Measured by using neonatal water trap and 2.5-meter long neonatal sampling line. <5s@100mL/min <6.5s@70mL/min Measured by using adult water trap and 2.5-meter long adult sampling line.	
Total system response time	<3.5s@100mL/min <4s@70mL/min Measured by using neonatal water trap and 2.5-meter long neonatal sampling line. <5.5s@100mL/min <7s@70mL/min Measured by using adult water trap and 2.5-meter long adult sampling line.	
Pump rate	70 mL/min and 100 mL/min optional. The flow control accuracy is ±15% of the set value or ±15mL/min, whichever is greater.	

Sidestream CO <sub>2</sub> alarm limits	Range	Step
EtCO <sub>2</sub> high limit	(low limit + 2) to 99 mmHg	1 mmHg
EtCO <sub>2</sub> low limit	0 to (high limit - 2) mmHg	
FiCO <sub>2</sub> high limit	1 to 99 mmHg	

## B.11 Compressor Specifications

Compressor Specifications		
Input voltage	220 to 240 V	110 to 120 V
Input frequency	50/60Hz	60Hz
Input current	3A	6A
Output pressure range	300 to 450 kPa	
Noise	Less than 50dB (A)	
Continuous flow	$\geq 30$ L/min at output pressure of 300kPa	
Peak flow	Greater than 180 L/min for more than 0.8 seconds at one barometric pressure	
Dew point	Lower than the room temperature by 5°C at flow of 30 L/min	

## B.12 O<sub>2</sub> Sensor Specifications

O <sub>2</sub> sensor	
Output	9 to 13 mV at 210 hPa O <sub>2</sub>
Range	0 to 1500hPa O <sub>2</sub>
100% O <sub>2</sub> signal deviation	100±1%
Resolution	1 hPa O <sub>2</sub>
Expected service life	1.5 x 10 <sup>6</sup> % for measurement (20°C) 0.8 x 10 <sup>6</sup> % for measurement (40°C)
Response time ((21% air to 100% O <sub>2</sub> ))	<15s
Linearity	Linear 0-100% O <sub>2</sub>
Operating temperature range	-20°C to +50°C
Temperature compensation	±2% of fluctuation at 0-40°C
Pressure range	50 to 200 kPa
Relative humidity	0 to 99%
100% O <sub>2</sub> concentration output drift	Over one year of typical value <5%
Material	White ABS
Packaging	Sealed package
Period of validity	Not more than 13 months after unpacked (in compliance with the conditions specified by the manufacturer)

Effect of interfering gas	
Gas under test	Error (%O <sub>2</sub> )
50% He/50% O <sub>2</sub>	<1%
80% N <sub>2</sub> O/20% O <sub>2</sub>	1 to 1.5%
4% Halothane/28.8% O <sub>2</sub> /67.2% N <sub>2</sub> O	1.5% to 2%
5% Sevoflurane/28.5% O <sub>2</sub> / 66.5% N <sub>2</sub> O	1 to 1.5%
5% Enflurane/28.5% O <sub>2</sub> /66.5% N <sub>2</sub> O 1.8%	1.2 to 1.8%
5% Isoflurane/28.5% O <sub>2</sub> /66.5% N <sub>2</sub> O	1.2 to 1.8%
5% CO <sub>2</sub> / 28.5% O <sub>2</sub> /66.5% N <sub>2</sub> O	<1%

**Theory of Operation**

O<sub>2</sub> sensor can monitor the patient's FiO<sub>2</sub>. O<sub>2</sub> sensor is of the self-powered, diffusion limited, metal-air battery type comprising an anode, electrolyte, diffusion barrier and air cathode as shown below:

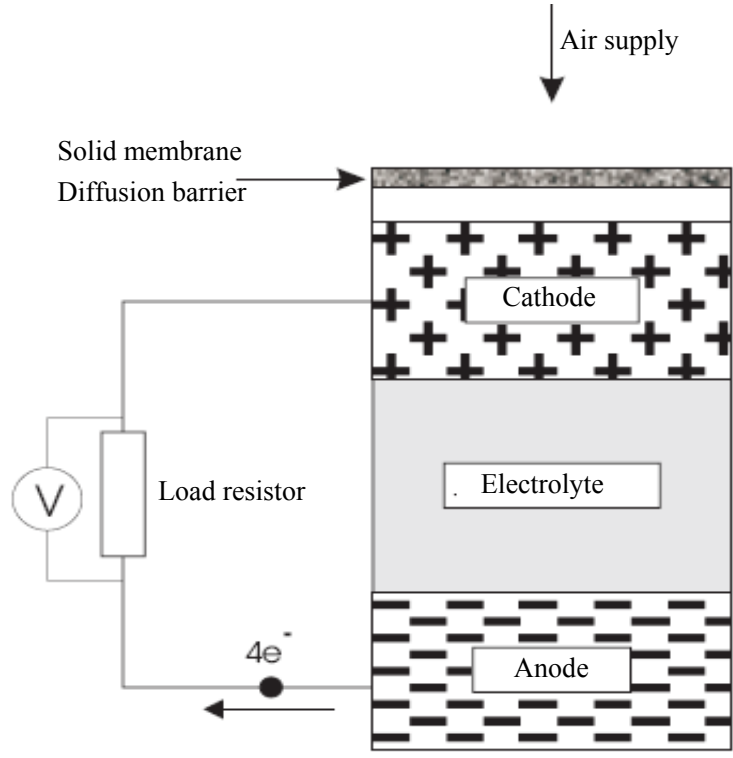

At the cathode oxygen is reduced to hydroxyl ions according to the equation:

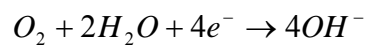

The hydroxyl ions in turn oxidise the metal anode as follows:

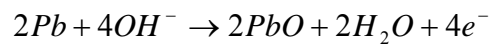

---

Overall the cell reaction may be represented as:

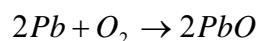

O<sub>2</sub> sensor is current generator, and the current is proportional to the rate of oxygen consumption (Faraday's Law). This current can be measured by connecting a resistor across the output terminals to produce a voltage signal. If the passage of oxygen into the sensor is purely diffusion limited, by the solid membrane diffusion barrier, then this signal is a measure of the oxygen partial pressure.

#### **Signal Stability**

O<sub>2</sub> sensor has highly stable outputs over their operating lives. Typical sensor drift rates are less than 1% per month when O<sub>2</sub> sensor is exposed to gas in typical applications. Thus a sensor with a starting signal of 12mV in 210mBar oxygen will typically still be showing a signal greater than 10mV as it approaches the end of its life.

#### **Humidity Effects**

Under conditions where liquid condensation may occur, care is needed to ensure the gas access holes do not become blocked. If liquids form in the region of the gas access hole, the flow of gas to the sensor will be restricted. With gas access restricted, a low signal will result. If a sensor shows signs of being affected by condensation, normal operation may be restored by drying the sensor with a soft tissue. Under no circumstances should these sensors be heated to dry them out. Changes in humidity levels which affect the O<sub>2</sub> partial pressure will correspondingly alter the output signal of the sensor.

#### **Pressure Effects**

Since the sensor measures O<sub>2</sub> partial pressure, the output will rise and fall due to pressure changes which affect the O<sub>2</sub> partial pressure. Thus an increase in pressure of 10% at the sensor inlet will produce a 10% increase in signal output. Nitrous oxide is highly soluble in neutral and alkaline solutions. Where the sensor is exposed to high levels of nitrous oxide, the solubility of this gas can in fact cause the internal pressure to increase to the point where the seals fail. O<sub>2</sub> sensor incorporates a patented pressure relief system in the rear of the sensor, limiting the internal pressure build up due to N<sub>2</sub>O dissolving in the electrolyte to a figure well within the capacity of the sealing system. Test data shows that sensors are unaffected by months of operation in 100% N<sub>2</sub>O. Cross-interference tests with 10% CO<sub>2</sub> (balance O<sub>2</sub>) show virtually no interference from CO<sub>2</sub>.

#### **Temperature Dependence**

The rugged design of O<sub>2</sub> sensor means they are resistant to damage from extremes of high or low temperature. Even so, the sensor must never be exposed to temperatures at which the electrolyte will freeze (approx. -25°C), or temperatures which will harm the components of the sensor, ie. the plastic or seals (>70°C). Sensor lifetime is governed by the mass of lead available to react with oxygen and its rate of consumption. High oxygen partial pressures and high temperatures will increase the sensor output current, thus shortening the operating life.



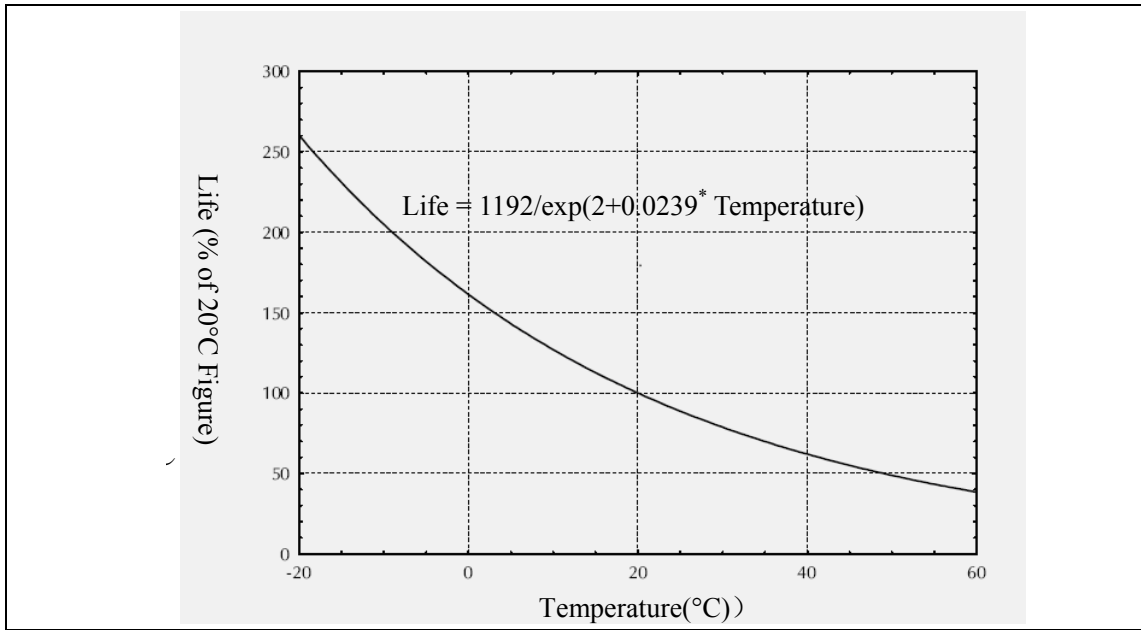

---

**FOR YOUR NOTES**

# C EMC

---

---

SynoVent E5 ventilator is in compliance with IEC 60601-1-2 for EMC.

The essential performance verified during the immunity testing comprised of  $V_{del}$  control accuracy,  $V_{del}$  monitoring accuracy, monitoring of the airway pressure, CO2 Accuracy and O2 Accuracy.

## NOTE

---

- **Using accessories other than those specified may result in increased electromagnetic emission or decreased electromagnetic immunity of the equipment.**
  - **The ventilator or its components should not be used adjacent to or stacked with other equipment. If adjacent or stacked use is necessary, the ventilator or its components should be observed to verify normal operation in the configuration in which it will be used.**
  - **The ventilator needs special precautions regarding EMC and needs to be installed and put into service according to the EMC information provided below.**
  - **Other devices may interfere with this equipment even though they meet the requirements of CISPR.**
  - **When the input signal is below the minimum amplitude provided in technical specifications, erroneous measurements could result.**
  - **Use of portable or mobile communications devices can degrade the performance of the equipment.**
-

---

**Guidance and manufacture's declaration - electromagnetic emissions**

The SynoVent E5 ventilator is intended for use in the electromagnetic environment specified below. The customer or the user of the SynoVent E5 ventilator should assure that it is used in such an environment.

<b>Emissions test</b>	<b>Compliance</b>	<b>Electromagnetic environment - guidance</b>
RF emissions CISPR 11	Group 1	The SynoVent E5 ventilator uses RF energy only for its internal function. Therefore, its RF emissions are very low and are not likely to cause any interference in nearby electronic equipment.
RF emissions CISPR 11	Class B	The SynoVent E5 ventilator is suitable for use in all establishments, including domestic establishments and those directly connected to the public low-voltage power supply network that supplies buildings used for domestic purposes.
Harmonic emissions IEC 61000-3-2	Class A	
Voltage fluctuations/flicker emissions IEC 61000-3-3	Complies	

<b>Guidance and manufacture's declaration - electromagnetic immunity</b>			
The SynoVent E5 ventilator is intended for use in the electromagnetic environment specified below. The customer or the user of the SynoVent E5 ventilator should assure that it is used in such an environment.			
<b>IMUNITY test</b>	<b>IEC 60601 test level</b>	<b>Compliance level</b>	<b>Electromagnetic environment - guidance</b>
Electrostatic discharge (ESD) IEC 61000-4-2	±6 kV contact ±8 kV air	±6 kV contact ±8 kV air	Floors should be wood, concrete or ceramic tile. If floors are covered with synthetic material, the relative humidity should be at least 30%.
Electrical fast transient/burst IEC 61000-4-4	±2 kV for power supply lines ±1 kV for input/output lines (>3 m)	±2 kV for power supply lines ±1 kV for input/output lines (>3 m)	Mains power quality should be that of a typical commercial or hospital environment.
Surge IEC 61000-4-5	±1 kV line(s) to line(s) ±2 kV line(s) to earth	±1 kV line(s) to line(s) ±2 kV line(s) to earth	Mains power quality should be that of a typical commercial or hospital environment.
Voltage dips, short interruptions and voltage variations on power supply input lines IEC 61000-4-11	<5 % $U_T$ (>95 % dip in $U_T$ ) for 0.5 cycle  40 % $U_T$ (60 % dip in $U_T$ ) for 5 cycles  70 % $U_T$ (30 % dip in $U_T$ ) for 25 cycles  <5 % $U_T$ (>95 % dip in $U_T$ ) for 5 s	<5 % $U_T$ (>95 % dip in $U_T$ ) for 0.5 cycle  40 % $U_T$ (60 % dip in $U_T$ ) for 5 cycles  70 % $U_T$ (30 % dip in $U_T$ ) for 25 cycles  <5 % $U_T$ (>95 % dip in $U_T$ ) for 5 s	Mains power quality should be that of a typical commercial or hospital environment. If the user of SynoVent E5 ventilator requires continued operation during power mains interruptions, it is recommended that SynoVent E5 ventilator be powered from an uninterruptible power supply.
Power frequency (50/60 Hz) magnetic field IEC 61000-4-8	3 A/m	3 A/m	Power frequency magnetic fields should be at levels characteristic of a typical location in a typical commercial or hospital environment.
Note: $U_T$ is the a.c. mains voltage prior to application of the test level.			

Guidance and Manufacturer's declaration - electromagnetic immunity			
The SynoVent E5 ventilator is intended for use in the electromagnetic environment specified below. The customer or the user of the SynoVent E5 ventilator should assure that it is used in such an environment as described below.			
IMMUNITY test	IEC60601 TEST LEVEL	Compliance level	Electromagnetic environment - guidance
Conducted RF IEC61000-4-6	3 Vrms 150 kHz to 80 MHz Outside ISM bands <sup>a</sup>	3 Vrms	Portable and mobile RF communications equipment should be used no closer to any part of the SynoVent E5 ventilator, including cables, than the recommended separation distance calculated from the equation appropriate for the frequency of the transmitter. <b>Recommended separation distances</b> $d = 1.2\sqrt{P}$
	10 Vrms 150 kHz to 80 MHz In ISM bands <sup>a</sup>	10 Vrms	$d = 1.2\sqrt{P}$
Radiated RF IEC61000-4-3	10V/m 80MHz~2.5GHz	10 V/m	$d = 1.2\sqrt{P}$ 80 MHz~800 MHz $d = 2.3\sqrt{P}$ 800 MHz~2.5 GHz Where, $P$ is the maximum output power rating of the transmitter in watts (W) according to the transmitter manufacturer and $d$ is the recommended separation distance in meters (m). <sup>b</sup> Field strengths from fixed RF transmitters, as determined by an electromagnetic site survey <sup>c</sup> , should be less than the compliance level in each frequency range <sup>d</sup> . Interference may occur in the vicinity of equipment marked with the following  symbol: .

Note 1: At 80 MHz and 800 MHz, the separation distance for the higher frequency range applies.

Note 2: These guidelines may not apply in all situations. Electromagnetic propagation is affected by absorption and reflection from structures, objects and people.

a. The ISM (Industrial, Scientific and Medical) bands between 150 kHz and 80 MHz are 6.765 MHz to 6.795 MHz; 13.553 MHz to 13.567 MHz; 26.957 MHz to 27.283 MHz; and 40.66 MHz to 40.70 MHz.

b. The compliance levels in the ISM frequency bands between 150 kHz and 80 MHz and in the frequency range 80 MHz to 2,5 GHz are intended to decrease the likelihood that mobile/portable communications equipment could cause interference if it is inadvertently brought into patient areas. For this reason, an additional factor of 10/3 has been incorporated into the formulae used in calculating the recommended separation distance for transmitters in these frequency ranges.

c. Field strengths from fixed transmitters, such as base stations for radio (cellular/cordless) telephones and land mobile radios, amateur radio, AM and FM radio broadcast and TV broadcast cannot be predicted theoretically with accuracy. To assess the electromagnetic environment due to fixed RF transmitters, an electromagnetic site survey should be considered. If the measured field strength in the location in which the SynoVent E5 ventilator is used exceeds the applicable RF compliance level above, the SynoVent E5 ventilator should be observed to verify normal operation. If abnormal performance is observed, additional measures may be necessary, such as reorienting or relocating the SynoVent E5 ventilator.

d. Over the frequency range 150 kHz to 80 MHz, field strengths should be less than 3 V/m.

<b>Recommended separation distance between portable and mobile RF communications equipment and the SynoVent E5 ventilator</b>			
The SynoVent E5 ventilator is intended for use in an electromagnetic environment in which radiated RF disturbance are controlled. The customer or the user of the SynoVent E5 ventilator can help prevent electromagnetic interference by maintaining a minimum distance between portable and mobile RF communications equipment (transmitters) and the SynoVent E5 ventilator as recommended below, according to the maximum output power of the communications equipment.			
<b>Rated maximum output power of transmitter (W)</b>	<b>Separation distance according to frequency of the transmitter</b>		
	m		
	150 kHz to 80 MHz	80 MHz to 800 MHz	800 MHz to 2.5 GHz
	$d = 1.2\sqrt{P}$	$d = 1.2\sqrt{P}$	$d = 2.3\sqrt{P}$
0.01 0	.12	0.12	0.23
0.1 0	.38	0.38	0.73
1 1	.2	1.2	2.3
10 3.8		3.8	7.3
100 12		12	23
For transmitters rated at a maximum output power not listed above, the recommended separation distance $d$ in meters (m) can be determined using the equation applicable to the frequency of the transmitter, where $P$ is the maximum output power rating of the transmitter in watts (W) according to the transmitter manufacturer.			
Note 1: At 80 MHz and 800 MHz, the separation distance for the higher frequency range applies.			
Note 2: An additional factor of 10/3 has been incorporated into the formulae used in calculating the recommended separation distance for transmitters in the ISM frequency bands between 150 kHz and 80 MHz and in the frequency range 80 MHz to 2,5 GHz to decrease the likelihood that mobile/portable communications equipment could cause interference if it is inadvertently brought into patient areas.			
Note 3: These guidelines may not apply in all situations. Electromagnetic propagation is affected by absorption and reflection from structures, objects and people.			



# D Alarm Messages

This chapter lists physiological and technical alarm messages.

Note that in this chapter:

- ◆ Column P stands for the default alarm level: H for high, M for medium and L for low.
- ◆ For each alarm message, corresponding actions are given instructing you to troubleshoot problems. If the problem persists, contact your service personnel.

## D.1 Physiological Alarm Messages

Source	Alarm message	P	Cause and action
<b>Ventilator parameters</b>	Paw Too High	H	Airway pressure exceeds the set pressure high alarm limit. Check the hoses for occlusion, increase pressure alarm limit, or decrease gas volume delivered.
	Paw Too Low	H	Real time airway pressure lasts 15s during mechanic ventilation, or is equal to or more than the alarm limit (PEEP+4 cmH2O) during one mechanic ventilation cycle.
	FiO2 Too High	H	The inspired O2 concentration is higher than the FiO2 high alarm limit for at least 20s. Check the Air supply and calibrate the O2 sensor.
	FiO2 Too Low	H	The inspired O2 concentration is lower than the FiO2 low alarm limit for at least 20s or is lower than 18%. Check the O2 supply and calibrate the O2 sensor.
	TVe Too High	M	The measured TVe value is greater than or equal to TVe high alarm limit for six continuous mechanical ventilation cycles. Check the ventilation setting parameters. Check the expiratory flow sensor for water build-up. Perform zero calibration.
	MV Too High	H	The measured MV value is greater than or equal to MV high alarm limit. Check if trigger sensitivity setting is too low. Check if the tidal volume setting or breathing frequency setting is too high.
	MV Too Low	H	The measured MV value is lower than MV low alarm limit. Check if the tidal volume setting or breathing frequency setting is too low. Check the hoses for leakage.
	Apnea	H	The time of failure to detect respiration exceeds Tapnea.

	Apnea ventilation	H	Apnea ventilation mode is started when the time of failure to detect respiration exceeds Tapnea. When this alarm is triggered, press [ <b>Alarm Reset</b> ] key and the alarm disappears. The system returns to the previous ventilation mode.
	ftot Too High	M	The total breathing frequency is greater than ftot high alarm limit. Check the ventilation parameter settings. Especially, check if the trigger level setting is normal. Check for leakage which results in mis-trigger.
	Pressure Limited	L	The airway pressure reaches Plimit. Increase Plimit or decrease TV setting. Check the hoses for leakage. When this alarm is triggered, press [ <b>Alarm Reset</b> ] key and the alarm disappears.
<b>CO2 module</b>	EtCO2 Too High	M	The measured parameter value exceeds the alarm limit. Check the patient's physiological condition. Make sure that patient type and alarm limit settings are correct.
	EtCO2 Too Low	M	
	FiCO2 Too High	M	

## D.2 Technical Alarm Messages

Source	Alarm message	P	Cause and action
<b>System</b>	Low Battery Voltage	M	Battery voltage is lower than the threshold value. Connect AC power supply immediately .In case of power failure, apply manual ventilation mode to help the patient to breathe. If the batteries cannot be fully charged within 24 hours, contact your service personnel.
	Battery in Use	L	The system is currently powered by batteries. Connect AC power supply. When this alarm is triggered, after connecting to the power, press [ <b>Alarm Reset</b> ] key and the alarm disappears.
	System DOWN for battery depletion!	H	Battery capacity is depleted and the system will shut down in a few minutes. Connect AC power supply immediately. In case of power failure, apply manual ventilation mode to help the patient to breathe. If the batteries cannot be fully charged within 24 hours, contact your service personnel.
	Battery Undetected	M	No batteries are installed.
	Power Supply Voltage Error	H	Internal power supply voltage is abnormal. Restart the ventilator. If the problem persists, contact your service

			personnel.
RT Clock Need Reset	L		There is button cell available in the system but the clock is reset in case of power failure. Contact your service personnel.
RT Clock Not Exist	H		There is no button cell available in the system or the battery has no capacity. The clock chip is faulty. Contact your service personnel.
IP Address Conflict	L		This message is displayed when there are conflicts between IP address settings and disappears until the conflicts are resolved. Set IP address again.
Loading Default Config. Failed	L		Loading configuration is failed. Reload the configuration. If the problem persists, contact your service personnel.
Restoring Last Config. Failed	L		Restoring configuration is failed. Restart the ventilator or reload the configuration. If the problem persists, contact your service personnel.
SD Storage Card Error	L		Storage card is not available or is failed. Replace the storage card.
Insp. Hold Interrupted	L		This alarm is triggered when the Insp. Hold key is pressed and held longer than the time limit. The alarm is cancelled when the Insp. Hold key is released.
Exp. Hold Interrupted	L		This alarm is triggered when the Exp. Hold key is pressed and held longer than the time limit. The alarm is cancelled when the Exp. Hold key is released.
Keyboard Comm Stop	H		Keyboard malfunction. Contact your service personnel.
Keyboard Selftest Error	H		Keyboard selftest error. Contact your service personnel.
Ventilator Reset Error	H		One of ventilator modules is powered on abnormally. Push the Alarm Reset key to cancel this alarm. When this alarm is triggered, press [ <b>Alarm Reset</b> ] key and the alarm disappears.
Key Error	M		This alarm is triggered when the hard key or rotary encoder is pressed and held for more than 35s.
Memory Error	H		The memory has an error. Restart the ventilator. If the problem persists, contact your service personnel.
PCON2 Selftest Error	H		The key control board has an error during power-on. Restart the ventilator. If the problem persists, contact your service personnel.

<b>Ventilator parameters</b>	Air Supply Pressure Low	H	The supply gas pressure is low. Check the status of supply gas. If the alarm continues
	O2 Supply Pressure Low	H	although supply gas is normal, contact your service personnel.
	No Gas Supply Pressure	H	Air supply pressure low and O2 supply pressure low occur every second simultaneously. 1. Make sure that the patient is in safe ventilation status. 2. Check the actual pressures of Air and O2 supplies. 3. Check that Air and O2 supply devices and connections are in good condition. 4. Check Air and O2 supply pressure switches.
	Airway Leak?	L	The airway is leaky. Check the airway for leakage and restore it to good condition.
	Airway Obstructed?	H	The airway is obstructed. Check the airway for leakage and restore it to good condition.
	Tube Disconnected?	H	The tube is disconnected. Restore tube connection.
	TV Not Achieved	L	Tidal volume is less than the set tidal volume by over 70%. Check ventilation setting parameters to see if the ventilation volume is too large. Check if the supply gases are normal. Check if the expiratory flow sensor has a deviation and perform zero calibration. Check the hoses for leakage.
	Pinsp Not Achieved	L	Inspiratory pressure is less than the set inspiratory pressure by over 70%. Check ventilation setting parameters to see if the inspiratory pressure is too large. Check if TV high alarm limit is set too low. Check if the supply gases are normal. Check the hoses for leakage.
	Sustained Airway Pressure	H	The airway pressure measured by any pressure sensor is greater than or equal to the set PEEP+15 cmH2O for 15s continuously. Check the breathing circuit for occlusion. Check if the expiratory time is too short.
	PEEP Too High	H	The measured PEEP exceeds PEEP+5 cmH2O within any fully mechanical ventilation cycle. Check the breathing circuit for occlusion. Check if the expiratory time is too short.
Tinsp too Long	L	In PSV mode, the gas delivery time exceeds 4.5s for adult and 1.5s for pediatric for three continuous cycles. This alarm is not triggered if pressure sensor or flow sensor is faulty.	

			Check for leakage. Check if the expiratory trigger sensitivity is too low.
	Ctrl Module Comm Error	L	Restart the ventilator. If the problem persists, contact your service personnel.
	Ctrl Module Comm Stop	H	
	Ctrl Module Selftest Error	H	
	Protection Module Comm Error	L	
	Protection Module Comm Stop	H	
	Protection Module Selftest Error	H	
	Heating Module Failure	L	
	Fan Failure	M	
	Pressure Sensor Failure	H	
	Exp. Flow Sensor Failure	H	
	Internal temperature too high	M	
	O2 Sensor Failure	M	
	O2 Sensor Unconnected	L	The O2 sensor is not connected. Re-connect the O2 sensor.
	Please calibrate O2 sensor.	L	Calibrate the O2 sensor.
	Please perform flow calibration.	H	Calibrate the flow sensor.
	Please perform pressure calibration.	H	Calibrate pressure.
	Air Insp. Limb Failure	H	The ventilator air limb supply is abnormal. Check the gas supply and perform system test. If the alarm is not cancelled, contact your service personnel.
	O2 Insp. Limb Failure	H	The ventilator O2 limb supply is abnormal. Check the gas supply and perform system test. If the alarm is not cancelled, contact your service personnel.
	Insp. Gas Temp Too High	H	The gas temperature exceeds 45°C. Restart the ventilator. If the problem persists, contact your service personnel.
	Buzzer Failure	L	The buzzer is faulty. Restart the ventilator. If the problem persists, contact your service personnel.

	Nebulizer Valve Failure	M	The nebulizer valve is faulty. Restart the ventilator. If the problem persists, contact your service personnel.
	3-way Valve Failure	M	The 3-way valve is faulty. Restart the ventilator. If the problem persists, contact your service personnel.
	Insp. Temperature Sensor Failure	H	The inspiratory temperature sensor is faulty. Restart the ventilator. If the problem persists, contact your service personnel.
	Volume Limited	L	In pressure mode, the inspired tidal volume exceeds the high alarm limit. Expiration is switched to when the high limit is reached. Check for leakage or change parameter. Decrease pressure setting or increase tidal volume alarm limit.
	Ctrl Module Init Error	H	The control module selftest is passed at power-on. But monitoring module system software's sending parameter configuration to monitoring module is failed. Restart the ventilator. If the problem persists, contact your service personnel.
	Protection Module Init Error	H	The protection module selftest is passed at power-on. But protection module system software's sending parameter configuration to protection module is failed. Restart the ventilator. If the problem persists, contact your service personnel.
<b>CO2 module</b>	CO2 Init Error	H	An error occurs during CO2 module initialization. The CO2 module is not installed properly or is faulty. Contact your service personnel.
	CO2 Selftest Error	H	An error occurs during CO2 module selftest. Restart the ventilator. If the problem persists, contact your service personnel.
	CO2 Comm Stop	L	CO2 module malfunction or communication failure occurs. Restart the ventilator. If the problem persists, contact your service personnel.
	CO2 Comm Error	H	CO2 module communication failure. Restart the ventilator. If the problem persists, contact your service personnel.
	CO2 Sensor High Temp	L	The temperature of the sensor assembly is too high (>63°C). Check, stop using or replace the sensor.
	CO2 Sensor Low Temp	L	The temperature of the sensor assembly is too low (<5°C). Check, stop using or replace the sensor.
	CO2 High Airway Pressure	L	The airway pressure is too high (>790 mmHg). Check the pneumatic connections. Make sure that the ventilator application site meets the environmental specifications. Check for special sources that affect the ambient pressure. Attempt to restart the ventilator.

CO2 Low Airway Pressure	L	The airway pressure is too low (<428 mmHg).An error occurred to the airway pressure. Check the patient and pneumatic connections. Attempt to restart the ventilator.
O2 High Barometric	L	The barometric pressure is greater than 790 mmHg. Check the pneumatic connections. Make sure that the ventilator application site meets the environmental specifications. Check for special sources that affect the ambient pressure. Attempt to restart the ventilator.
CO2 Low Barometric	L	The barometric pressure is less than 428 mmHg. Check the pneumatic connections. Make sure that the ventilator application site meets the environmental specifications. Check for special sources that affect the ambient pressure. Attempt to restart the ventilator.
CO2 Hardware Error	H	Errors may occur to: 1. External A/D sampling 2.5V 2. 12V power supply voltage 3. Internal A/D sampling 2.5V 4. Pump 5. 3-way valve Restart the ventilator. If the problem persists, contact your service personnel.
CO2 Sampleline Occluded	L	An error or occlusion may occur to the sampling line. Check the CO2 pneumatic line.
CO2 Zero Failed	L	Deviation of gain input signal is too great to be adjusted.
CO2 System Error	L	The alarm can be triggered by multiple system errors. Restart the ventilator. If the problem persists, contact your service personnel.
CO2 No Watertrap	L	The water trap is disconnected or is not connected properly. Check the water trap.
EtCO2 Overrange	L	The measured parameter value is outside the measurement range (error range is counted). Do the test after zeroing and calibration. If the problem persists, contact your service personnel.
FiCO2 Overrange	L	

---

**FOR YOUR NOTES**



# E Factory Defaults

---

---

This chapter lists the most important factory default settings which are not user-adjustable. When necessary, you can restore the factory default settings.

## E.1 CO2 Module

CO2 module	Factory default setting
Working mode	Measure
Pump rate	100 mL/min
Humidity compensation	OFF
CO2 calibration concentration setting	3%
EtCO2 low limit	Adult: 15 mmHg; Pediatric: 20 mmHg
EtCO2 high limit	Adult/pediatric: 50 mmHg
FiCO2 high limit	Adult/pediatric: 4 mmHg

## E.2 Alarm

Alarm	Factory default setting
Paw high limit	50 cmH2O
MV high limit	$TV * f * 1.5$
MV low limit	$TV * f * 0.8$
TVe high limit	TV setting value x 2
ftot high limit	OFF
Tapnea	15s
Alarm Volume	2

## E.3 Ventilation Mode

Ventilation mode	Factory default setting
<b>V-A/C</b>	
TV	Adult: 7 kg/mL x IBW and 100 ml, whichever is greater; pediatric: 7 kg/mL x IBW (round down) (when TV/f source is IBW or height & gender) Adult: 500 ml; pediatric: 50 ml (when TV/f source is patient type)
O2%	40%
Plimit	40 cmH2O
PEEP	3 cmH2O
△int.PEEP	OFF
Sigh	OFF
Tinsp	Adult: 1.7s; pediatric: 0.7s
I:E	1:2
Assist	ON
F-Trig	Adult: 2.0 L/min; pediatric: 1.0 L/min
Flow	Adult: 20 L/min; pediatric: 8 L/min
f	Adult: 12 bpm; pediatric: 29 bpm
ATRC (only in non-NIV mode)	OFF
Tube diameter (only in non-NIV mode)	8.0mm
Compensation proportion (only in non-NIV mode)	80%
Compensation of expiration (only in non-NIV mode)	ON
<b>P-A/C</b>	
O2%	40%
PEEP	3 cmH2O
Pinsp	15 cmH2O
Tinsp	Adult: 1.7s; pediatric: 0.7s
I:E	1:2
Tslope	0.2s
Assist	ON
F-Trig	Adult: 2.0 L/min; pediatric: 1.0 L/min

f	Adult: 12 bpm; pediatric: 29 bpm
ATRC (only in non-NIV mode)	Off
<b>CPAP/PSV</b>	
O2%	40%
PEEP	3 cmH2O
$\Delta$ Psupp	0 cmH2O
Tslope	0.2s
F-Trig	Adult: 2.0 L/min; pediatric: 1.0 L/min
Exp%	Auto
$\Delta$ Papnea	15 cmH2O
fapnea	Adult: 12 bpm; pediatric: 29 bpm
Tinsp (only in NIV mode)	Adult: 1.7s; pediatric: 0.7s
ATRC (only in non-NIV mode)	OFF
Tube diameter (only in non-NIV mode)	8.0mm
Compensation proportion (only in non-NIV mode)	80%
Compensation of expiration (only in non-NIV mode)	ON
<b>V-SIMV</b>	
TV	Adult: 7 kg/mL x IBW and 100 ml, whichever is greater; pediatric: 7 kg/mL x IBW (round down) (when TV/f source is patient weight) Adult: 500 ml; pediatric: 50 ml (when TV/f source is patient type)
O2%	40%
fSIMV	Adult: 5 bpm; pediatric: 20 bpm
Plimit	40 cmH2O
PEEP	3 cmH2O
$\Delta$ Psupp	0 cmH2O
Tinsp	Adult: 1.7s; pediatric: 0.7s
Tslope	0.2s
F-Trig	Adult: 2.0 L/min; pediatric: 1.0 L/min
Exp%	Auto
Flow	Adult: 20 L/min; pediatric: 8 L/min
fapnea	Adult: 12 bpm; pediatric: 29 bpm

Apnea ventilation	ON
ATRC (only in non-NIV mode)	OFF
Tube diameter (only in non-NIV mode)	8.0mm
Compensation proportion (only in non-NIV mode)	80%
Compensation of expiration (only in non-NIV mode)	ON
<b>P-SIMV</b>	
O2%	40%
fSIMV	Adult: 5 bpm; pediatric: 20 bpm
Pinsp	15 cmH2O
PEEP	3 cmH2O
$\Delta P_{supp}$	0 cmH2O
Tinsp	Adult: 1.7s; pediatric: 0.7s
Tslope	0.2s
F-Trig	Adult: 2.0 L/min; pediatric: 1.0 L/min
Exp%	Auto
fapnea	Adult: 12 bpm; pediatric: 29 bpm
Apnea ventilation	ON
ATRC (only in non-NIV mode)	OFF
Tube diameter (only in non-NIV mode)	8.0mm
Compensation proportion (only in non-NIV mode)	80%
Compensation of expiration (only in non-NIV mode)	ON
<b>PRVC</b>	
TV	Adult: 7 kg/mL x IBW and 100 ml, whichever is greater; pediatric: 7 kg/mL x IBW (round down) (when TV/f source is patient weight)
	Adult: 500 ml; pediatric: 50 ml (when TV/f source is patient type)
f	Adult: 12 bpm; pediatric: 29 bpm
O2%	40%
Plimit	40 cmH2O
PEEP	3 cmH2O
Tinsp	Adult: 1.7s; pediatric: 0.7s

I:E	1:2
Assist	ON
F-Trig	Adult: 2.0 L/min; pediatric: 1.0 L/min
ATRC (only in non-NIV mode)	OFF
Tube diameter (only in non-NIV mode)	8.0mm
Compensation proportion (only in non-NIV mode)	80%
Compensation of expiration (only in non-NIV mode)	ON
<b>Duolevel</b>	
O2%	40%
$\Delta$ Psupp	0 cmH2O
Tslope	0.2s
Phigh	15 cmH2O
Plow	5 cmH2O
Thigh	Adult: 1.7s; pediatric: 0.7s
Tlow	Adult: 3.3s; pediatric: 1.4s
F-Trig	Adult: 2.0 L/min; pediatric: 1.0 L/min
Exp%	Auto
$\Delta$ Papnea	15 cmH2O
fapnea	Adult: 12 bpm; pediatric: 29 bpm
ATRC (only in non-NIV mode)	OFF
Tube diameter (only in non-NIV mode)	8.0mm
Compensation proportion (only in non-NIV mode)	80%
Compensation of expiration (only in non-NIV mode)	ON
<b>APRV</b>	
O2%	40%
Tslope	0.2s
Phigh	15 cmH2O
Plow	5 cmH2O
Thigh	Adult: 1.7s; pediatric: 0.7s
Tlow	Adult: 3.3s; pediatric: 1.4s

---

△Papnea	15 cmH2O
fapnea	Adult: 12 bpm; pediatric: 29 bpm
ATRC (only in non-NIV mode)	OFF
Tube diameter (only in non-NIV mode)	8.0mm
Compensation proportion (only in non-NIV mode)	80%
Compensation of expiration (only in non-NIV mode)	ON

# F Symbols and Abbreviations

---

---

## F.1 Symbols

A	ampere
Ah	ampere hour
bpm	Breaths per minute
°C	centigrade
cc	cubic centimetre
cm	centimeter
cmH <sub>2</sub> O	centimeter of water
dB	decibel
°F	fahrenheit
g	gram
hr	hour
Hz	hertz
hPa	hectopascal
inch	inch
k	kilo-
kg	kilogram
kPa	kilopascal
L	litre
lb	pound
m	meter
mAh	milliampere hour
mbar	millibar
mg	milligram
min	minute
ml	milliliter
mm	millimeter
mmHg	millimeter of mercury
ms	millisecond
mV	millivolt
mW	milliwatt

---

nm	nanometer
ppm	part per million
s	second
V	volt
VA	volt ampere
$\Omega$	ohm
$\mu\text{A}$	microampere
$\mu\text{V}$	microvolt
W	watt
-	minus
%	percent
/	per; divide; or
~	to
^	power
+	plus
=	equal to
<	less than
>	greater than
$\leq$	less than or equal to
$\geq$	greater than or equal to
$\pm$	plus or minus
$\times$	multiply
©	copyright



---

## F.2 Abbreviations

APRV	Airway Pressure Release Ventilation
ATPD	Ambient Temperature and Pressure Dry
BTPS	Body Temperature and Pressure Saturated
Cdyn	Dynamic Compliance
CPAP/PSV	Continuous Positive Airway Pressure/ Pressure Support Ventilation
Cstat	Static Compliance
DuoLevel	Duo Level Ventilation
EtCO <sub>2</sub>	End-tidal Carbon Dioxide
FiCO <sub>2</sub>	Fraction of Inspired Carbon Dioxide
FiO <sub>2</sub>	Inspired Oxygen Concentration
Flow	Flow
f	Breathing Frequency
fapnea	Frequency of Apnea Ventilation
fmand	Mandatory Frequency
fspn	Spontaneous Frequency
fSIMV	Frequency of SIMV
ftot	Total Breathing Frequency
I:E	Inspiratory Time:Expiratory Time Ratio
MV	Minute Volume
MVspn	Spontaneous Minute Volume
MVleak	Leakage Minute Volume
NIF	Negative Inspiratory Force
NIV	Non-Invasive Ventilation
O <sub>2</sub>	Oxygen
P0.1	100ms Occlusion Pressure
P-A/C	Pressure - Assist/Control Ventilation
Paw	Airway Pressure
PEEP	Positive End-Expiratory Pressure
PEEPi	Intrinsic PEEP
Pinsp	Pressure Control Level of Inspiration

Plimit	Pressure Limit Level
Pmean	Mean Pressure
Ppeak	Peak Pressure
Pplat	Plateau Pressure
PRVC	Pressure Regulated Volume Control Ventilation
P-SIMV	Pressure - Synchronized Intermittent Mandatory Ventilation
$\Delta$ int.PEEP	Intermittent Positive End-Expiratory Pressure
$\Delta$ Papnea	Pressure of Apnea Ventilation (relative to PEEP/Plow)
$\Delta$ Psupp	Pressure Support Level(relative to PEEP/Plow)
Rinsp	Inspiration Resistance
Rexp	Expiration Resistance
Sigh	Sigh
SIMV	Synchronized Intermittent Mandatory Ventilation
Texp	Time of Expiration
Thigh	Time of High Pressure
Tinsp	Time of Inspiration
Tlow	Time of Low Pressure
Tplat	Time of Plat In Inspiratory Period
Tslope	Time of Pressure Rising
TV	Tidal Volume
TVe	Expired Tidal Volume
TVe spn	Spontaneous Expired Tidal Volume
TVi	Inspired tidal Volume
Volume	Gas Volume
Vtrap	Volume of Trap Gas
V-A/C	Volume - Assist/Control Ventilation
V-SIMV	Volume - Synchronized Intermittent Mandatory Ventilation
RSBI	Rapid Shallow Breath Index
WOB	Work of Breath



