

**DC-33/DC-35/DC-36/DC-38/DC-39/
DC-40/DC-41/DC-42/DC-43/DC-44/
DC-45/DC-40S/DC-40 Pro/
DC-40 Exp/DC-40T**

Diagnostic Ultrasound System

Operator's Manual

[Basic Volume]

Contents

Intellectual Property Statement	I
Responsibility on the Manufacturer Party	I
Warranty	II
Exemptions	II
Customer Service Department	II
Important Information	III
About This Manual	III
Notation Conventions	III
Operator's Manuals	IV
Manuals on Paper	IV
Software Interfaces in this Manual	V
Conventions	V
Product Differences	V
1 Safety Precautions	1-1
1.1 Safety Classification	1-1
1.2 Meaning of Signal Words	1-2
1.3 Meaning of Safety Symbols	1-2
1.4 Safety Precautions	1-3
1.5 Latex Alert	1-9
1.6 Warning Labels	1-10
2 System Overview	2-1
2.1 Intended Use	2-1
2.2 Contraindication	2-1
2.3 Product and Model Code	2-1
2.4 Product Specifications	2-1
2.4.1 Imaging Mode	2-2
2.4.2 Power supply	2-2
2.4.3 Environmental Conditions	2-2
2.4.4 Size and Weights	2-3
2.5 System Configuration	2-3
2.5.1 Standard Configuration	2-3
2.5.2 Probes Available	2-3
2.5.3 Options	2-4
2.5.4 Peripherals Supported	2-6
2.6 Introduction of Each Unit	2-7
2.7 I/O Panel	2-10
2.8 Power Supply Panel	2-11
2.9 Physiological-signal Panel	2-11
2.10 Control Panel	2-12
2.11 Symbols	2-17
3 System Preparation	3-1
3.1 Move/Posit the System	3-1
3.2 Power Supply	3-2
3.2.1 Connecting AC Power Supply	3-2
3.2.2 Powered by Batteries	3-3
3.2.3 Equipotential Terminal	3-3
3.3 Power ON/OFF	3-3

3.3.1	Powering ON the System	3-3
3.3.2	Powering OFF the System	3-5
3.3.3	Standby	3-5
3.4	Monitor Adjusting	3-6
3.4.1	Monitor Position Adjusting	3-6
3.4.2	Adjusting Brightness/Contrast on the Monitor	3-7
3.4.3	Control Panel Position Adjustment	3-8
3.5	Connecting a Probe.....	3-9
3.5.1	Connecting a Probe	3-9
3.5.2	Disconnecting a probe	3-9
3.6	Connecting Peripheral Devices.....	3-10
3.6.1	Connecting the USB Devices	3-10
3.6.2	Connecting a Footswitch	3-10
3.6.3	Graph /Text printer	3-11
3.6.4	Installing Analog Video Printer.....	3-14
3.6.5	Installing Digital Video Printer.....	3-16
3.6.6	Installing a Wireless Printer	3-16
3.6.7	Installing/ uninstalling Probe/Gel Holder.....	3-16
3.7	Basic Screen and Operation	3-18
3.7.1	Basic Screen.....	3-18
3.7.2	Basic Operations of Screens	3-22
3.7.3	Touchscreen	3-23
3.7.4	Soft keyboard.....	3-24
4	Exam Preparation	4-1
4.1	To Start an Exam	4-1
4.2	Patient Information	4-1
4.2.1	New Patient Information	4-1
4.2.2	Retrieve Patient Information	4-5
4.3	Select Exam Mode and Probe	4-8
4.3.1	Dual-probe Switch	4-8
4.4	Select the Imaging Mode	4-9
4.5	Activate& Continue an Exam	4-9
4.5.1	Activate an Exam.....	4-9
4.5.2	Continue Exam	4-9
4.6	Pause & End an Exam	4-9
4.6.1	Pause Exam	4-9
4.6.2	End Exam	4-10
5	Image Optimization.....	5-1
5.1	Imaging Mode.....	5-1
5.1.1	Switching Between Imaging Modes.....	5-1
5.1.2	Image Adjustment.....	5-1
5.1.3	Quickly Saving Image Settings.....	5-2
5.2	B Mode Image Optimization	5-3
5.2.1	Basic Procedures for B Mode Imaging	5-3
5.2.2	B Mode Parameters.....	5-3
5.2.3	B Mode Image Optimization	5-4
5.3	M Mode Image Optimization	5-10
5.3.1	Basic Procedures for M Mode Imaging	5-10
5.3.2	M Mode Image Parameters	5-10
5.3.3	M Mode Image Optimization.....	5-11

5.4	Color Mode Image Optimization.....	5-13
5.4.1	Basic Procedures for Color Mode Imaging.....	5-13
5.4.2	Color Mode Image Parameters	5-13
5.4.3	Color Mode Image Optimization	5-13
5.5	Power Mode Image Optimization.....	5-18
5.5.1	Basic Procedures for Power Mode Imaging.....	5-18
5.5.2	Power Mode Image Parameters.....	5-18
5.5.3	Power Mode Image Optimization	5-18
5.6	PW/CW Doppler Mode.....	5-20
5.6.1	Basic Procedures for PW/CW Mode Exam.....	5-20
5.6.2	PW/CW Mode Image Parameters	5-21
5.6.3	PW/CW Mode Image Optimization.....	5-22
5.7	Color M Mode.....	5-27
5.7.1	Enter Color M Mode.....	5-27
5.7.2	Exit Color M Mode.....	5-27
5.7.3	Color M Mode Image Parameters	5-27
5.8	Anatomical M Mode.....	5-28
5.8.1	Free Xros M Imaging (Anatomical M-Mode)	5-28
5.8.2	Free Xros CM (Curved Anatomical M-Mode).....	5-29
5.9	TDI.....	5-30
5.9.1	Basic Procedures for TDI Imaging.....	5-31
5.9.2	TDI Image Parameters	5-31
5.9.3	TDI Image Optimization.....	5-31
5.9.4	TDI Quantitative Analysis (QA).....	5-32
5.10	3D/4D	5-36
5.10.1	Overview.....	5-36
5.10.2	Note Before Use	5-40
5.10.3	Static 3D	5-42
5.10.4	iLive	5-52
5.10.5	4D	5-54
5.10.6	Smart 3D.....	5-55
5.10.7	iPage (Multi-Slice Imaging).....	5-57
5.11	iScape View (Real-time Panoramic Imaging).....	5-61
5.11.1	Basic Procedures for iScape Imaging	5-61
5.11.2	Image Acquisition.....	5-62
5.11.3	iScape Viewing	5-62
5.11.4	Cine Review.....	5-64
5.12	Elastography	5-64
5.12.1	Basic Procedure for Elastography	5-64
5.12.2	Enter/Exit	5-65
5.12.3	Pressure Hint Curve	5-65
5.12.4	Cine Review.....	5-66
5.13	Contrast Imaging	5-66
5.13.1	Basic Procedures for Contrast Imaging.....	5-67
5.13.2	Measurement, Comment and Body Mark.....	5-69
6	Display & Cine Review	6-1
6.1	Image Display.....	6-1
6.1.1	Splitting Display	6-1
6.2	Image Magnification	6-1
6.2.1	Spot.....	6-1
6.2.2	Pan	6-2

6.2.3	iZoom (Full-screen Zooming)	6-2
6.3	Freeze/Unfreeze the Image	6-2
6.3.1	Imaging Mode Switching When Frozen	6-2
6.3.2	Imaging Display Format Switching When Frozen	6-3
6.4	Cine Review	6-3
6.4.1	Entering/ Exiting Cine Review	6-4
6.4.2	Cine Review in 2D Mode (B/B+Color/B+Power/B+TVI/B+TEI)	6-4
6.4.3	Cine Review in M or D Mode	6-5
6.4.4	Linked Cine Review	6-5
6.5	Image Compare	6-6
6.5.1	Cine Compare	6-6
6.5.2	Frame Compare	6-6
6.6	Cine Saving	6-6
6.7	Cine Memory	6-7
6.7.1	Cine Memory Setting	6-7
6.8	Cine Settings	6-8
7	ECG	7-1
7.1	ECG Operation Basic Procedures	7-2
7.2	Parameter Description	7-3
7.3	ECG Review	7-3
8	Measurement	8-1
8.1	Basic Operations	8-1
8.2	General Measurements	8-2
8.2.1	2D General Measurements	8-2
8.2.2	M General Measurements	8-3
8.2.3	Doppler General Measurements	8-3
8.3	Application Measurement	8-3
8.4	Measurement Accuracy	8-4
9	Comments and Body Marks	9-1
9.1	Comments (Annotations)	9-1
9.1.1	Comments Basic Procedures	9-1
9.1.2	Touch Screen Display in Comments	9-2
9.1.3	Adding Comments	9-3
9.1.4	Moving Comments	9-4
9.1.5	Modifying (Editing) Comments	9-5
9.1.6	Deleting Comments	9-5
9.1.7	Comment Setting	9-6
9.2	Body Marks	9-6
9.2.1	Touch Screen Display in Body Mark	9-6
9.2.2	Adding Body Marks	9-6
9.2.3	Moving Body Marks	9-7
9.2.4	Deleting Body Marks	9-7
10	Patient Data Management	10-1
10.1	Patient Information Management	10-1
10.1.1	Enter Patient Information	10-1
10.1.2	Patient Information Setting	10-1
10.2	Image File Management	10-2
10.2.1	Memory Media	10-2
10.2.2	Image File Formats	10-2

10.2.3	Image Storage Preset.....	10-3
10.2.4	Quickly Saving Images to the System.....	10-3
10.2.5	Quickly Saving Full Screen Image to the System	10-4
10.2.6	Thumbnails	10-4
10.2.7	Image Review and Analysis.....	10-4
10.2.8	iVision	10-6
10.2.9	Sending Image File.....	10-8
10.3	Report Management.....	10-9
10.4	Patient Data Management (iStation)	10-10
10.4.1	Viewing Patient Information.....	10-10
10.4.2	Searching a Patient	10-11
10.4.3	Patient Data View & Management.....	10-11
10.5	iStorage	10-13
10.6	Print.....	10-13
10.6.1	Setting.....	10-13
10.6.2	Image Print	10-13
10.6.3	Report Print.....	10-14
10.7	Backup Files through DVD Drive	10-14
10.8	Patient Task Management.....	10-15
10.9	Administration.....	10-16
10.9.1	Access Setting	10-16
10.9.2	Setting Access Control	10-16
10.9.3	System Login	10-16
10.9.4	Adding/Deleting a User.....	10-17
10.9.5	Modify Password	10-18
11	DICOM.....	11-1
11.1	DICOM Preset.....	11-1
11.1.1	Network Preset	11-1
11.1.2	DICOM Local Preset.....	11-2
11.1.3	Service Preset	11-3
11.2	Verify Connectivity.....	11-8
11.3	DICOM Services.....	11-8
11.3.1	DICOM Storage	11-8
11.3.2	DICOM Print	11-10
11.3.3	DICOM Worklist.....	11-11
11.3.4	MPPS.....	11-12
11.3.5	Storage Commitment.....	11-12
11.3.6	Query/Retrieve.....	11-13
11.4	DICOM Media Storage	11-14
11.5	Structured Report	11-15
11.6	DICOM Task Management.....	11-15
12	Setup.....	12-1
12.1	System Preset	12-2
12.1.1	Region	12-3
12.1.2	General	12-4
12.1.3	Image Preset	12-5
12.1.4	Application	12-6
12.1.5	OB Preset	12-6
12.1.6	Key Configuration	12-6
12.1.7	Admin.....	12-7

12.2	Exam Preset.....	12-8
12.3	Measure Preset.....	12-8
12.4	Print Preset.....	12-9
12.5	Network Preset.....	12-10
12.5.1	Local TCP/IP.....	12-10
12.5.2	iStorage.....	12-12
12.5.3	MedTouch/MedSight Preset	12-13
12.6	Maintenance.....	12-13
12.6.1	Option	12-13
12.6.2	Other Settings.....	12-14
12.7	System Information	12-14
13	Probes and Biopsy	13-1
13.1	Probe.....	13-1
13.1.1	Name and Function of Each Part of the Probe.....	13-3
13.1.2	Orientation of the Ultrasound Image and the Probe Head	13-4
13.1.3	Procedures for Operating	13-4
13.1.4	Wearing the Probe Sheath	13-7
13.1.5	Probes Cleaning and Disinfection	13-8
13.1.6	Storage and Transportation	13-10
13.2	Biopsy Guide	13-11
13.2.1	Basic Procedures for Biopsy Guiding	13-13
13.2.2	Needle-guided Brackets	13-14
13.2.3	Needle-guided Bracket Inspection and Installation	13-21
13.2.4	Verifying the Biopsy Guide Line.....	13-26
13.2.5	Removing the Needle-guided Bracket.....	13-27
13.2.6	Clean and Sterilize the Needle-guided Bracket.....	13-29
13.2.7	Storage and Transportation	13-31
13.2.8	Disposal	13-31
13.3	Middle Line	13-31
14	Acoustic Output.....	14-1
14.1	Concerns with Bioeffects.....	14-1
14.2	Prudent Use Statement	14-1
14.3	ALARA Principle (As Low As Reasonably Achievable).....	14-1
14.4	MI/TI Explanation	14-2
14.4.1	Basic Knowledge of MI and TI.....	14-2
14.4.2	MI/TI Display.....	14-3
14.5	Acoustic Power Setting	14-3
14.6	Acoustic Power Control.....	14-4
14.7	Acoustic Output.....	14-4
14.7.1	Derated Ultrasonic Output Parameters	14-4
14.7.2	Limits of Acoustic Output	14-5
14.7.3	Differences between Actual and Displayed MI and TI.....	14-5
14.8	Measurement Uncertainty	14-6
14.9	References for Acoustic Power and Safety.....	14-6
15	EMC Guidance and Manufacturer's Declaration.....	15-1
16	System Maintenance	16-1
16.1	Daily Maintenance.....	16-1
16.1.1	Cleaning the System	16-1
16.1.2	Clean the Peripherals	16-5
16.1.3	Checking the Probe	16-5

16.1.4	Checking the Power Cable and Plug.....	16-5
16.1.5	Checking Appearance	16-5
16.1.6	Backup of the System Hard Drive	16-6
16.2	Troubleshooting.....	16-7
Appendix A	Barcode Reader.....	A-1
Appendix B	Electrical Safety Inspection	B-1
Appendix C	iScanHelper	C-1
Appendix D	Wireless LAN	D-1
Appendix E	Ultrasound Gel Warmer	E-1
Appendix F	Batteries.....	F-1



©2016 Shenzhen Mindray Bio-Medical Electronics Co., Ltd. All rights Reserved.



For this Operator's Manual, the issue date is 2016-10.

Intellectual Property Statement

SHENZHEN MINDRAY BIO-MEDICAL ELECTRONICS CO., LTD. (hereinafter called Mindray) owns the intellectual property rights to this Mindray product and this manual. This manual may refer to information protected by copyright or patents and does not convey any license under the patent rights or copyright of Mindray, or of others.

Mindray intends to maintain the contents of this manual as confidential information. Disclosure of the information in this manual in any manner whatsoever without the written permission of Mindray is strictly forbidden.

Release, amendment, reproduction, distribution, rental, adaptation, translation or any other derivative work of this manual in any manner whatsoever without the written permission of Mindray is strictly forbidden.

 ,  ,  ,  ,  ,  BeneView, WATO,

BeneHeart,  are the trademarks, registered or otherwise, of Mindray in China and other countries. All other trademarks that appear in this manual are used only for informational or editorial purposes. They are the property of their respective owners.

Responsibility on the Manufacturer Party

Contents of this manual are subject to change without prior notice.

All information contained in this manual is believed to be correct. Mindray shall not be liable for errors contained herein or for incidental or consequential damages in connection with the furnishing, performance, or use of this manual.

Mindray is responsible for the effects on safety, reliability and performance of this product, only if:

- all installation operations, expansions, changes, modifications and repairs of this product are conducted by Mindray authorized personnel;
- the electrical installation of the relevant room complies with the applicable national and local requirements; and
- the product is used in accordance with the instructions for use.



Note

This equipment must be operated by skilled/trained clinical professionals.



It is important for the hospital or organization that employs this equipment to carry out a reasonable service/maintenance plan. Neglect of this may result in machine breakdown or personal injury.

Warranty

THIS WARRANTY IS EXCLUSIVE AND IS IN LIEU OF ALL OTHER WARRANTIES, EXPRESSED OR IMPLIED, INCLUDING WARRANTIES OF MERCHANTABILITY OR FITNESS FOR ANY PARTICULAR PURPOSE.

Exemptions

Mindray's obligation or liability under this warranty does not include any transportation or other charges or liability for direct, indirect or consequential damages or delay resulting from the improper use or application of the product or the use of parts or accessories not approved by Mindray or repairs by people other than Mindray authorized personnel.

This warranty shall not extend to:

- **Malfunction or damage caused by improper use or man-made failure.**
- **Malfunction or damage caused by unstable or out-of-range power input.**
- **Malfunction or damage caused by force majeure such as fire and earthquake.**
- **Malfunction or damage caused by improper operation or repair by unqualified or unauthorized service people.**
- **Malfunction of the instrument or part whose serial number is not legible enough.**
- **Others not caused by instrument or part itself.**

Customer Service Department

Manufacturer: Shenzhen Mindray Bio-Medical Electronics Co., Ltd.
Address: Mindray Building, Keji 12th Road South, High-tech industrial park, Nanshan, Shenzhen 518057, P.R. China
Website: www.mindray.com
E-mail service@mindray.com
Address:
Tel: +86 755 81888998
Fax: +86 755 26582680

EC-Representative: Shanghai International Holding Corp. GmbH(Europe)
Address: Eiffestraße 80, Hamburg 20537, Germany
Tel: 0049-40-2513175
Fax: 0049-40-255726

Important Information

1. It is the customer's responsibility to maintain and manage the system after delivery.
2. The warranty does not cover the following items, even during the warranty period:
 - (1) Damage or loss due to misuse or abuse.
 - (2) Damage or loss caused by Acts of God such as fires, earthquakes, floods, lightning, etc.
 - (3) Damage or loss caused by failure to meet the specified conditions for this system, such as inadequate power supply, improper installation or environmental conditions.
 - (4) Damage or loss due to use of the system outside the region where the system was originally sold.
 - (5) Damage or loss involving the system purchased from a source other than Mindray or its authorized agents.
3. This system shall not be used by persons other than fully qualified and certified medical personnel.
4. Do not make changes or modifications to the software or hardware of this system.
5. In no event shall Mindray be liable for problems, damage, or loss caused by relocation, modification, or repair performed by personnel other than those designated by Mindray.
6. The purpose of this system is to provide physicians with data for clinical diagnosis. It is the physician's responsibility for diagnostic procedures. Mindray shall not be liable for the results of diagnostic procedures.
7. Important data must be backed up on external memory media.
8. Mindray shall not be liable for loss of data stored in the memory of this system caused by operator error or accidents.
9. This manual contains warnings regarding foreseeable potential dangers, but you shall always be alert to dangers other than those indicated as well. Mindray shall not be liable for damage or loss that results from negligence or from ignoring the precautions and operating instructions described in this operator's manual.
10. If the manager for this system is changed, be sure to hand over this operator's manual to the new manager.

About This Manual

This operator's manual describes the operating procedures for this diagnostic ultrasound system and the compatible probes. To ensure safe and correct operations, carefully read and understand the manual before operating the system.

Notation Conventions

In this operator's manual, the following words are used besides the safety precautions (refer to "Safety Precautions"). Please read this operator's manual before using the system.



CAUTION: The diagnostic ultrasound system is not intended for ophthalmic use. Its use in this clinical specialty is contraindicated.

Operator's Manuals

You may receive multi-language manuals in compact disc or paper. Please refer to English manual for latest information and register information.

The content of the operator manual, such as screens, menus or descriptions, may be different from what you see in your system. The content varies depending upon the software version, options and configuration of the system.

Manuals on Paper

- Operator's Manual [Basic Volume]: Describes the basic functions and operations of the system, safety precautions, exam modes, imaging modes, preset, maintenance and acoustic output, etc.
- Operator's Manual [Advanced Volume]: Describes measurement preset, measurements and calculations, etc.
- Operator's Manual [Acoustic Power Data and Surface Temperature Data]: Contains data tables of acoustic output for transducers.
- Operation Note: Contains quick guide for basic operations of the system.

<p>NOTE:</p> <ol style="list-style-type: none">1. The manuals in CD are the manuals translated into languages other than English according to English manuals.2. When you find that the contents of the manuals in CD are NOT consistent with the system or English manuals, please ONLY refer to the corresponding English manuals.3. The accompanying manuals may vary depending upon the specific system you purchased. Please refer to the packing list.

Software Interfaces in this Manual

Depending on the software version, preset settings and optional configuration, the actual interfaces may be different from those in this manual.

Conventions

In this manual, these conventions are used to describe the buttons on the control panel, the items in menu, buttons in dialog box and some basic operations:

- <Button>: The angular bracket indicates buttons, knobs and other controls on control panel or keyboard.
- [Item in menu (soft menu) and button in dialog box]: The square bracket indicates items in menu or buttons in dialog box.
- Click [Item or Button]: Move the cursor to the item or button and press <Set>, or click it on the menu.
- [Item in Menu]→[Item in Submenu]: Select a submenu item following the path.
- [Dyn Rng (Value)]: Indicates menu items with parameter, (value) shows the current value of the item.

Product Differences

Product Model	B-Hist	B-Profile	PPSA	Color Velocity
DC-33	√	×	√	√
DC-35	×	×	√	√
DC-36	×	√	√	√
DC-38	√	√	×	√
DC-39	√	√	√	√
DC-40	√	√	√	√
DC-41	×	×	√	√
DC-42	×	√	√	√
DC-43	√	√	×	√
DC-44	√	×	√	√
DC-45	√	√	√	×
DC-40S	√	√	×	×
DC-40 Pro	√	×	×	√
DC-40 Exp	×	√	×	√
DC-40T	×	√	√	×

NOTE:“√” means the option is configured on the product.

1 Safety Precautions

1.1 Safety Classification





- According to the type of protection against electric shock:
Class I equipment powered by outer power & equipment powered by inner batteries
- According to the degree of protection against electric shock:
Type-BF applied part
- According to the degree of protection against harmful ingress of water:
Main unit: IPX0
Probes: IPX7
Footswitch: FS-81-SP-2 (one-pedal) belongs to IPX8.
971-SWNOM (2-pedal or 3-pedal) belongs to IP68.
- According to the degree of safety of application in the presence of a FLAMMABLE ANESTHETIC MIXTURE WITH AIR or WITH OXYGEN OR NITROUS OXIDE:
EQUIPMENT not suitable for use in the presence of a FLAMMABLE ANESTHETIC MIXTURE WITH AIR or WITH OXYGEN OR NITROUS OXIDE
- According to the mode of operation:
CONTINUOUS OPERATION
- According to the installation and use:
MOBILE EQUIPMENT

1.2 Meaning of Signal Words

In this manual, the signal words "**⚠️ DANGER**", "**⚠️ WARNING**", "**⚠️ CAUTION**", "**NOTE**" and "Tips" are used regarding safety and other important instructions. The signal words and their meanings are defined as follows. Please understand their meanings clearly before reading this manual.

Signal word	Meaning
⚠️ DANGER	Indicates an imminently hazardous situation that, if not avoided, will result in death or serious injury.
⚠️ WARNING	Indicates a potentially hazardous situation that, if not avoided, could result in death or serious injury.
⚠️ CAUTION	Indicates a potentially hazardous situation that, if not avoided, may result in minor or moderate injury.
NOTE	Indicates a potentially hazardous situation that, if not avoided, may result in property damage.
Tips	Important information that helps you to operate the system more effectively.

1.3 Meaning of Safety Symbols

Symbol	Description
	Type-BF applied part. The ultrasound probes connected to this system are type-BF applied parts.
	Caution.
	Patient/user infection due to contaminated equipment. Be careful when performing the cleaning, disinfection and sterilization.
	Patient injury or tissue damage from ultrasound radiation. It is required to practice ALARA when operating ultrasound system.

1.4 Safety Precautions

Please observe the following precautions to ensure patient and operator's safety when using this system.

 **DANGER:** Do not operate this system and probes in an atmosphere containing flammable gasses or liquids such as anesthetic gasses, hydrogen, and ethanol, because there is danger of explosion.

-  **WARNING:**
1. Do not connect the power plug of this system to wall receptacles that meet the ratings indicated on the rating nameplate. If adapters or multifunctional receptacles are used, it may cause the leakage current to exceed the safety requirement.
 2. In the environment that patient is 1.5 meters around, connect peripherals to the auxiliary power outlet which is capable of isolation protection, or power the peripherals by auxiliary output cable or isolation transformer complied with IEC 60601-1-1 or the power input of the same safety level.
 3. **DO NOT** use power supply of different phases to power peripherals, like power supply of air-conditioning.
 4. When using peripherals not powered by the auxiliary output of the ultrasound system, or using peripherals other than permitted by Mindray, make sure the overall leakage current of peripherals and the ultrasound system meets the requirement of the local medical device electrical regulation (like enclosure leakage current should be no more than 500uA of IEC 60601-1-1), and the responsibility is held by the user.
 5. Connect the grounding conductor before turning **ON** the system. Disconnect the grounding cable after turning **OFF** the system. Otherwise, electric shock may result.
 6. For the connection of power and grounding, follow the appropriate procedures described in this operator's manual. Otherwise, there is risk of electric shock. Do not connect the grounding cable to a gas pipe or water pipe; otherwise, improper grounding may result or a gas explosion may occur.
 7. Before cleaning the system, disconnect the power cord from the outlet. Otherwise, system failure and electric shock may result.
 8. This system is not water-proof. Do not use this system in any place where water leakage may occur. If any water is sprayed on or into the system, electric shock may result. If water is accidentally sprayed on or into the system, contact Mindray Customer Service Department or sales representative.

9. **DO NOT** use a probe that has a damaged, scratched surface, or exposed wiring of any kind. Immediately stop using the probe and contact Mindray Customer Service Department or sales representative. There is risk of electric shock if using a damaged or scratched probe.
10. Do not allow the patient to contact the live parts of the ultrasound system or other devices, e.g. signal I / O ports. Electric shock may occur.
11. Do not use an aftermarket probe other than those specified by Mindray. The probes may damage the system causing a profound failure, e.g. a fire in the worst case.
12. Do not subject the probes to knocks or drops. Use of a defective probe may cause an electric shock.
13. Do not open the covers and front panel of the system. Short circuit or electric shock may result when the system hardware is exposed and powered on.
14. Do not use this system when any digital device such as a high-frequency electrotome, high-frequency therapeutic device or defibrillator is applied already. Otherwise, there is a risk of electric shock to the patient.
15. Only use the ECG leads and PCG transducer provided with the physiology module; otherwise, electric shock may be resulted.
16. When moving the system, you should hold the handle; otherwise, damage may be resulted by abnormal force. Do not push the system from the left/right side; otherwise, it may be toppled over.
17. The auxiliary power output outlet in the system is used to supply power for the recommended peripheral devices. Do not connect other devices to the outlet, otherwise, the rated output power may be exceeded and failure may be resulted. Maximum output power of the outlet is 240VA (including the auxiliary output port in the printer compartment).
18. Accessory equipment (analog or digital) connected to the ultrasound system must comply with the relevant IEC standards (e.g., IEC 60950 information technology equipment safety standard and IEC 60601-1 medical equipment standard). Furthermore, all configurations must comply with the standard IEC 60601-1-1. It is the responsibility of the person, who connects additional equipment to the signal input or output ports and configures a medical system, to verify that the system complies with the requirements of IEC 60601-1-1. If you have any questions regarding these requirements, consult your sales representative.
19. Prolonged and repeated use of keyboards may result in hand or arm nerve disorders for some individuals. Observe the local safety or health regulations concerning the use of keyboards.
20. When using intra-cavity probes, do not activate the probe outside the patient's body.

21. **DO NOT touch the Signal I/O ports if in contact with the patient; otherwise patient injury may result.**



CAUTION:

1. **Precautions concerning clinical examination techniques:**
This system must be used only by qualified medical professionals.
This operator's manual does not describe clinical examination techniques. The clinician should select the proper examination techniques based on specialized training and clinical experience.
2. **Malfunctions due to radio wave:**
If a radio wave emitting device is used in the proximity of this system, it may interfere with operations. Do not use or take any devices transmitting RF signals (such as cellular phones, transceivers and radio controlled products) in the room placing the system.
If a person brings a device that generates radio waves near the system, ask him / her to immediately turn OFF the device.
3. **Precautions concerning movement of the system:**
Please install the system on a flat plane with casters locked. Otherwise, damage may be resulted by accidental moving.
Do not move the system laterally, which may result in damage in case of toppling.
Move the system slowly on the slope by two people, otherwise, damage may result in case of unexpected sliding.
Do not sit on the system, which may result individual falling in case of system moving.
Object placed on the monitor may fall and injure an individual.
Fasten and fully secure any peripheral device before moving the system. A loose peripheral device may fall and injure an individual.
When move the system on the steps, please take care to prevent the system from toppling.
4. If the circuit protector is tripped, it indicates that the system or a peripheral device was improperly shut down and the system is unstable. You cannot repair the system under this circumstance and must call the Mindray Customer Service Department or sales representative.
5. There is no risk of high-temperature burns during normal ultrasound examinations. It is possible for the surface temperature of the probe to exceed the body temperature of a patient due to environmental temperature and exam type combinations. Do not apply the probe to the same region on the patient for a long time. Apply the probe only for a period of time required for the purpose of diagnosis.
6. Do not use the system to examine a fetus for a long period of time.

7. The system and its accessories are not disinfected or sterilized prior to delivery. The operator is responsible for the cleaning and disinfection of probes and sterilization of biopsy brackets according to the manuals, prior to the use. All items must be thoroughly processed to completely remove harmful residual chemicals, which will not only be harmful to the human body, but also damage the accessory.
8. It is necessary to press <End Exam> to end the current scan that is in progress and clear the current Patient Information field. Otherwise, new patient data may be combined with the previous patient data.
9. Do not connect or disconnect the system's power cord or its accessories (e.g., a printer or a recorder) without turning OFF the system power first. This may damage the system and its accessories or cause electric shock.
10. If the system is powered off improperly during operation, it may result in data damage of the system hard disk or system failure.
11. Do not use a USB memory device (e.g., a USB flash drive, removable hard disk) which has unsafe data. Otherwise, system damage may result.
12. It is recommended to only use the video devices specified in this manual.
13. Do not use gel, disinfectant, probes, probe sheath or needle-guided brackets that are not compatible with the system.
14. The applied contrast agents should be compliant with the relevant local regulations.
15. Read the Acoustic Output Principle in the operation manual carefully before operating this system on clinical examination.
16. The cover contains natural rubber that can cause allergic reactions in some individuals.
17. Please use the ultrasound gel compliant with the relevant local regulations.
18. Normal operation may be affected by unstable mains power supply; it is recommended that our product be powered from an uninterruptible power supply.

- NOTE:**
1. DO NOT use the system in the vicinity of strong electromagnetic field (such as a transformer), which may affect the performance of the system.
 2. Do not use the system in the vicinity of high-frequency radiation source (e.g. cellular phones), which may affect the performance of the system or even lead to failure.
 3. When using or placing the system, keep the system horizontal to avoid imbalance.

4. To avoid damaging the system, do not use it in following environment:
 - Locations exposed to direct sunlight;
 - Locations subject to sudden changes in environmental temperature;
 - Dusty locations;
 - Locations subject to vibration;
 - Locations near heat generators;
 - Locations with high humidity.
5. Turn ON the system only after the power has been turned OFF for a while. If the system is turned ON immediately after being turned OFF, the system may not be rebooted properly and could malfunction.
6. Press <Freeze> key to freeze an image or turn off the power of the system before connecting or disconnecting a probe. Otherwise, the system and/or probe can be damaged.
7. Remove the ultrasound gel from the face of the probe when the examination is completed. Water in the gel may enter the acoustic lens and adversely affect the performance and safety of the probe.
8. You should properly back up the system to a secure external storage media, including system configuration, settings and patient data. Data stored to the system's hard drive may be lost due to system failure, improper operation or accident.
9. Do not apply external force to the control panel. Otherwise, the system may be damaged.
10. If the system is used in a small room, the room temperature may rise. Please provide proper ventilation and free air exchange.
11. To dispose of the system or any part, contact Mindray Customer Service Department or sales representative. Mindray is not responsible for any system content or accessories that have been discarded improperly. Mindray is not responsible for any system content or accessories that have been discarded improperly.
12. Electrical and mechanical performance may be degraded due to long usage (such as current leakage or distortion and abrasion); the image sensitivity and precision may become worse too. To ensure optimal system operations, it is recommended that you maintain the system under a Mindray service agreement.
13. The replaceable fuse is inside the chassis. Refer replacing job to Mindray service engineers or engineers authorized by Mindray only.
14. Do not turn OFF the power supply of the system during printing, file storage or invoking other system operations. An interrupted process may not be completed, and can become lost or corrupted.
15. The iScape feature constructs a single extended image from a series of individual image frames. The quality of the final image is user-dependent and requires skill to efficiently apply the feature and technique. Exercise caution when measurements are performed from an iScape image.
16. Ensure that the current exam date and time are the same as the system date and time.

Please read the following precautions carefully to ensure the safety of the patient and the operator when using the probes.

**WARNING:**

1. The probe is only for use with the specified ultrasonic diagnostic system. Please refer to the “2.5.2 Probes Available” to select the proper probe.
2. The ultrasonic probe must be used only by qualified professionals.
3. Confirm that the transducer and probe cable are normal before and after each examination. A defective probe may cause electric shock to the patient.
4. Do not subject the probe to shock. A defective probe may cause electric shock to the patient.
5. Do not disassemble the probe to avoid the possibility of electric shock.
6. Never immerse the probe connector into liquids such as water or disinfectant because the connector is not waterproof. Immersion may cause electric shock or malfunction.
7. A probe sheath must be installed over the probe before performing intra-cavity or intra-operative examination.

**CAUTION:**

1. When using the probe, wear sterile gloves to prevent infection.
2. Be sure to use sterile ultrasound gel. Please use the ultrasound gel compliant with the relevant local regulations. And manage the ultrasound gel properly to ensure that it does not become a source of infection.
3. In normal diagnostic ultrasound mode, there is no danger of a normal-temperature burn; however, keeping the probe on the same region of the patient for a long time may cause such a burn.
4. Do not use the carrying case for storing the probe. If the carrying case is used for storage, it may become a source of infection.
5. It is required to practice ALARA when operating ultrasound system. Minimize the acoustic power without compromising the quality of images.
6. The probe and accessories supplied with it are not delivered disinfected or sterilized. Sterilization (or high-level disinfect) before use is required.
7. Disposable components should be packaged sterile and for single-use only. Do not use if integrity of packaging violated or if expiration date has passed. Please use the disposable components compliant with the relevant local regulations.
8. Please use the disinfection or sterilization solution recommended in this operator’s manual; otherwise Mindray will not be liable for damage caused by other solutions. If you have any questions, please contact Mindray Customer Service Department or sales representative.
9. Do not use pre-lubricated condoms as a sheath. Lubricant may not be compatible with the probe material and damage may result.

10. The damage of the probe may be caused by the contact of improper gel or cleaner:

- **DO NOT soak or saturate probes in the strong polar solution of ethanol, chloride of lime, ammonium chloride, acetone or formaldehyde.**
- **DO NOT contact the probe with solutions or ultrasound gels containing oily medium such as mineral oil or lanoline.**

NOTE: Read the following precautions to prevent the probe from malfunction:

- Before connecting or disconnecting the probe, freeze or turn off the diagnostic ultrasound system.
- Clean and disinfect the probe before and after each examination.
- After the examination, wipe off the ultrasound gel thoroughly. Otherwise, the ultrasound gel may solidify and the image quality would be degraded.

Ambient conditions:

1. To prevent the probe from being damaged, do not use it where it will be exposed to:
 - Direct sunlight or X-rays
 - Sudden changes in temperature
 - Dust
 - Excessive vibration
 - Heat generators
2. Use probes under the following ambient conditions :
 - ambient temperature: 0°C to 40°C
 - relative humidity: 30% to 85% (no condensation)
 - atmospheric pressure: 700 hPa to 1060 hPa
3. Use D7-2E, D6-2NE probes under the following ambient conditions :
 - ambient temperature: 10°C to 40°C
 - relative humidity: 30% to 85% (no condensation)
 - atmospheric pressure: 700 hPa to 1060 hPa

Repeated disinfection will eventually damage the probe, please check the probe performance periodically.

NOTE: The following definition of the WEEE label applies to EU member states only: The use of this symbol indicates that this system should not be treated as household waste. By ensuring that this system is disposed of correctly, you will help prevent bringing potential negative consequences to the environment and human health. For more detailed information with regard to returning and recycling this system, please consult the distributor from whom you purchased the system.



For system products, this label may be attached to the main unit only.

1.5 Latex Alert

When choosing a probe sheath, it is recommended that you directly contact CIVCO for obtaining probe sheath, pricing information, samples and local distribution information. For CIVCO information, please contact the following:

CIVCO Medical Instruments

Tel: 1-800-445-6741





 **WARNING:** Allergic reactions in latex (natural rubber) sensitive patients may range from mild skin reactions (irritation) to fatal anaphylactic shock, and may include difficulty in breathing (wheezing), dizziness, shock, swelling of the face, hives, sneezing or itching of the eyes (FDA Medical Alert on latex products, “Allergic Reactions to Latex-containing Medical Devices”, issued on March 29, 1991).

1.6 Warning Labels

The warning labels are attached to this system in order to call your attention to potential hazards. The symbol  on the warning labels indicates safety precautions.

The warning labels use the same signal words as those used in the operator’s manual. Read operator’s manual carefully before using the system.

The name, pattern and meaning of each warning label are described as follows:

No.	Warning Labels	Meaning
1.		<p>a. Do not place the system on a sloped surface. Otherwise the system may slide, resulting in personal injury or the system malfunction. Two persons are required to move the system over a sloped surface.</p> <p>b. Do not sit on the system.</p> <p>c. DO NOT push the system when the casters are locked.</p> <p>d. Please carefully read this manual before use system.</p>
2.		Beware of excessive stress exerted to the system.
3.		Mind your hands.
4.		Please do not lift the hanger or try to push the ultrasound system by using it.
5.		Non-ionizing radiation

2 System Overview

2.1 Intended Use

The Diagnostic Ultrasound System is intended for use in gynecology, obstetrics, abdominal, pediatric, small parts, cephalic, transcranial, musculo-skeletal, cardiac, vascular, urology, orthopedics, nerve exam.

2.2 Contraindication

This system is not intended for ophthalmic use.

2.3 Product and Model Code

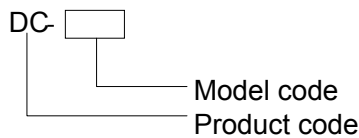

NOTE: The functions described in the operator's manual may vary depending upon the specific system you purchased.

2.4 Product Specifications

2.4.1 Imaging Mode

B Mode	B
M Mode	M Color M Mode (CM)
C Mode	Color Power (Dirpower)
D Mode	PW Doppler CW Doppler
Special Imaging	Tissue Doppler Imaging TDI QA iScape View Free Xros M/Free Xros CM 3D/4D Smart 3D Static 3D iPage iLive Contrast Imaging Elastography

2.4.2 Power supply

Voltage	100–240V~
Frequency	50/60Hz
Power consumption	600VA
Fuse	250V~ T10AH

2.4.3 Environmental Conditions

	Operational Conditions	Storage and Transportation Conditions
Ambient temperature	10°C~40°C	-20°C~55°C
Relative humidity	30%~85%	30%~95%
Atmospheric pressure	700hPa~1060hPa	700hPa~1060hPa

 WARNING: Do not use this system in the conditions other than those specified.
--

2.4.4 Size and Weights

- External dimensions:
 - 812mm (L)X600mm (W)X1331(1515)mm (H)
- Net weight: 130.87Kg (without the battery)

2.5 System Configuration

2.5.1 Standard Configuration

- Main unit
- Accessories
 - Operator's manuals
 - Ultrasound gel
 - Dust-proof cover
 - Probe ports dust-proof cover
 - Tray assembly
 - Left bracket for the intra-cavity probe
 - Right bracket for the intra-cavity probe
 - Probe holder
 - Probe holder for pencil probe
 - Cables
 - Grounding cable
 - Multilingual controls overlay

2.5.2 Probes Available

No.	Probe Model	Intended Use	Region Applied
1.	3C5A	Gynecology, obstetrics, abdominal, vascular, musculoskeletal, pediatric	Body surface
2.	7L4A	Small parts, vascular, pediatric, musculo-skeletal, abdominal, cephalic, orthopedic	Body surface
3.	6C2	Small parts, vascular, pediatric, musculo-skeletal, abdominal, cephalic, cardiac, nerve	Body surface
4.	L14-6	Small parts, vascular, pediatric, musculo-skeletal, abdominal, cephalic	Body surface
5.	V10-4B/V10-4	Gynecology, obstetrics, urology	Transvaginal
6.	7L5	Small parts, vascular, pediatric, musculo-skeletal, abdominal, cephalic, orthopedic	Body surface
7.	L7-3	Small parts, vascular, pediatric, musculo-skeletal, abdominal, cephalic, orthopedic	Body surface

No.	Probe Model	Intended Use	Region Applied
8.	P7-3	pediatric abdomen, pediatric cardia, neonatal cephalic, neonatal abdomen, neonatal cardiac, nerve, orthopedic	Body surface
9.	CB10-4E	Urology	Intracavitary
10.	L12-3E	Musculoskeletal, nerve, small parts, vascular, pediatric, abdominal	Body surface
11.	D7-2E	Obstetrics, gynecology, abdominal	Abdomen
12.	L14-6NE	Small parts, musculo-skeletal, nerve, vascular, pediatric	Body surface
13.	V11-3	Gynecology, obstetrics, urology	Intracavitary
14.	P4-2	Cardiac, abdominal, Pediatric, vascular	Body surface
15.	CW5s	Deep vascular, cardiac, transcranial	Body surface

Some of the probes have matched needle-guided brackets for biopsy, the available probes and the corresponding needle-guided brackets are listed as follows:

V10-4B/V10-4 CB10-4E/V11-3	NGB-004 Metal/needle un-detachable	/	16G, 17G, 18G
6C2	NGB-005 metal/needle un-detachable	12.7°, 24.2°	13G, 15G, 16G, 18G, 20G
3C5A	NGB-006 (plastic/needle detachable, metal/needle detachable)	25°, 35°, 45°	Plastic/needle detachable: 13G, 15G, 16G, 18G, 20G; Metal/needle detachable: 14G, 16G, 18G, 20G, 22G
7L4A/L12-3E/ 7L5/L14-6NE/ L7-3	NGB-007 plastic/needle detachable metal/needle detachable	40°, 50°, 60°	Metal/needle detachable: 14G, 16G, 18G, 20G, 22G; Plastic/needle detachable: 13G, 15G, 16G, 18G, 20G
P4-2	NGB-011 metal/needle un-detachable	11°, 23°	13G, 15G, 16G, 18G, 20G
L14-6	NGB-016 Metal/needle detachable	30°, 40°, 50°	14G, 16G, 18G, 20G, 22G

2.5.3 Options

No.	Item
1	ECG module (including ECG lead)
2	DC-IN cable (configured with ECG module)
3	Ultrasound gel warmer
4	4D module
5	CW module
6	Buit-in battery

No.	Item	
7	Built-in Wireless Adapter	
8	Pencil probe port	
9	Footswitch: (one-pedal/two-pedal/three-pedal)	
10	1D barcode reader	
11	Application software package	Nerve Package
12		Emergency&Critical Package
13		IMT
14		IVF
15		Smart OB
16		Smart NT
17	Smart Bladder	
18	Tissue Doppler Imaging	
19	iScape View	
20	Free Xros M	
21	Free Xros CM	
22	Smart 3D	
23	Static 3D	
24	4D	
25	iPage (configured with 4D module)	
26	Contrast Imaging	
27	Elastography Imaging	
28	iLive (configured with 4D module or Smart 3D)	
29	TDI QA (configured with TDI)	
30	iScanHelper	
31	DICOM	DICOM Basic
32		DICOM Worklist
33		DICOM MPPS
34		DICOM Query/Retrieve
35		DICOM OB/GYN Structured Report
36		DICOM Vascular Structured Report
37	DICOM Cardiac Structured Report	
		DICOM Basic should be configured first.

2.5.4 Peripherals Supported

No.	Item	Model
1.	Graph / text printer	HP Deskjet Ink Advantage 2020hc HP Officejet Pro 8100
2.	Digital Color Video Printer	SONY UP-D23/25MD
3.	Digital Black and White Video Printer	SONY UP-D897
4.	Analog Black and White Video Printer	MITSUBISHI P93W-Z SONY UP-X898MD
5.	Bar code reader	LS2208
6.	Footswitch	971- SWNOM (two-pedal or three-pedal) FS-81-SP-2 (one-pedal)

Parts that can be used within patient environment:

- Main unit.
- Probes.
- Footswitch.
- Printers: HP Deskjet Ink Advantage 2020hc, HP Officejet Pro 8100, SONY UP-D23/25MD, SONY UP-D897, MITSUBISHI P93W-Z, SONY UP-X898MD.

⚠ WARNING: This system complies with IEC60601-1-2:2007, and its RF emission meets the requirements of CISPR11 Class B. In a domestic environment, the customer or the user should guarantee to connect the system with Class B peripheral devices; otherwise RF interference may result and the customer or the user must take adequate measures accordingly.

2.6 Introduction of Each Unit

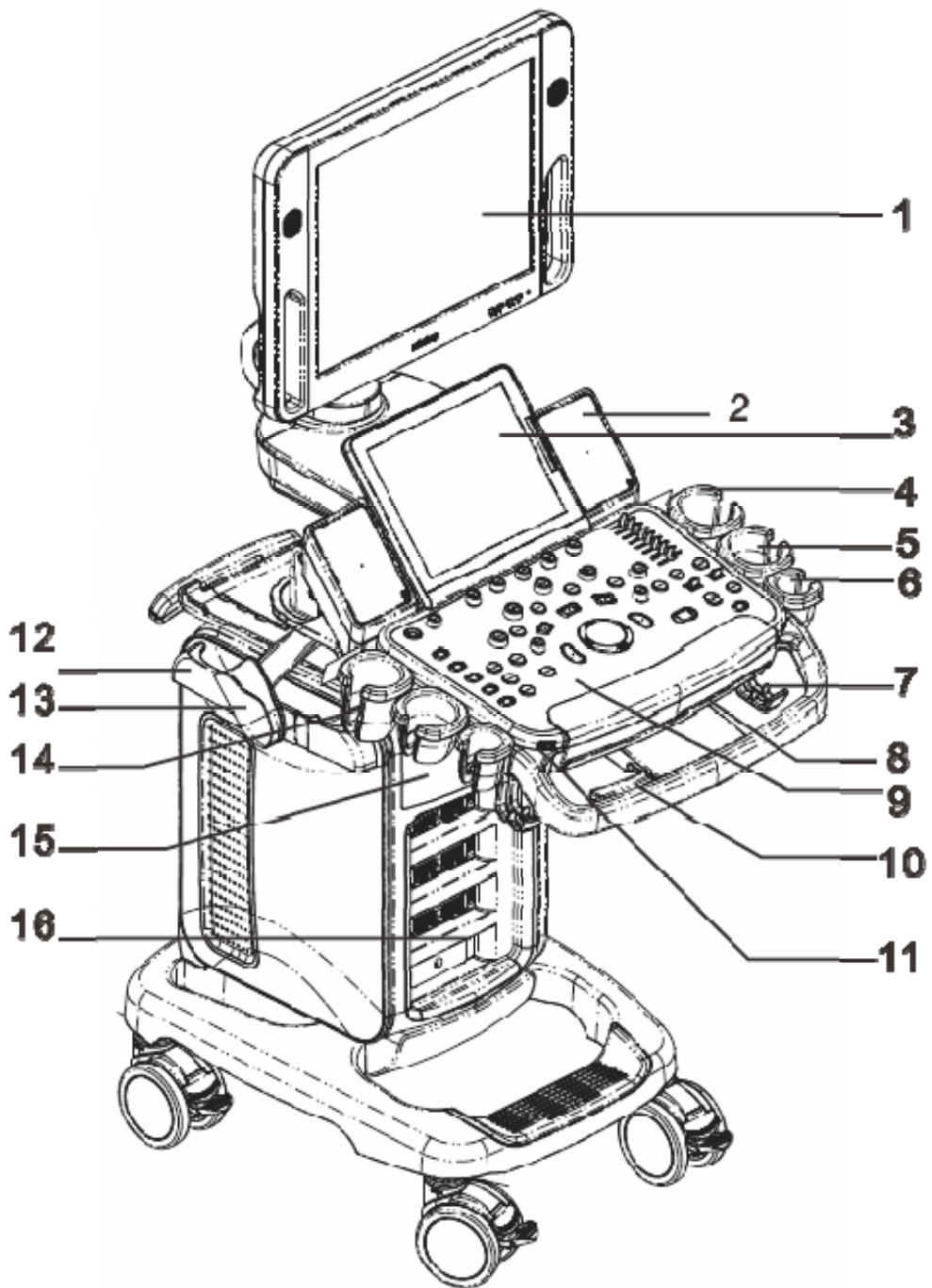

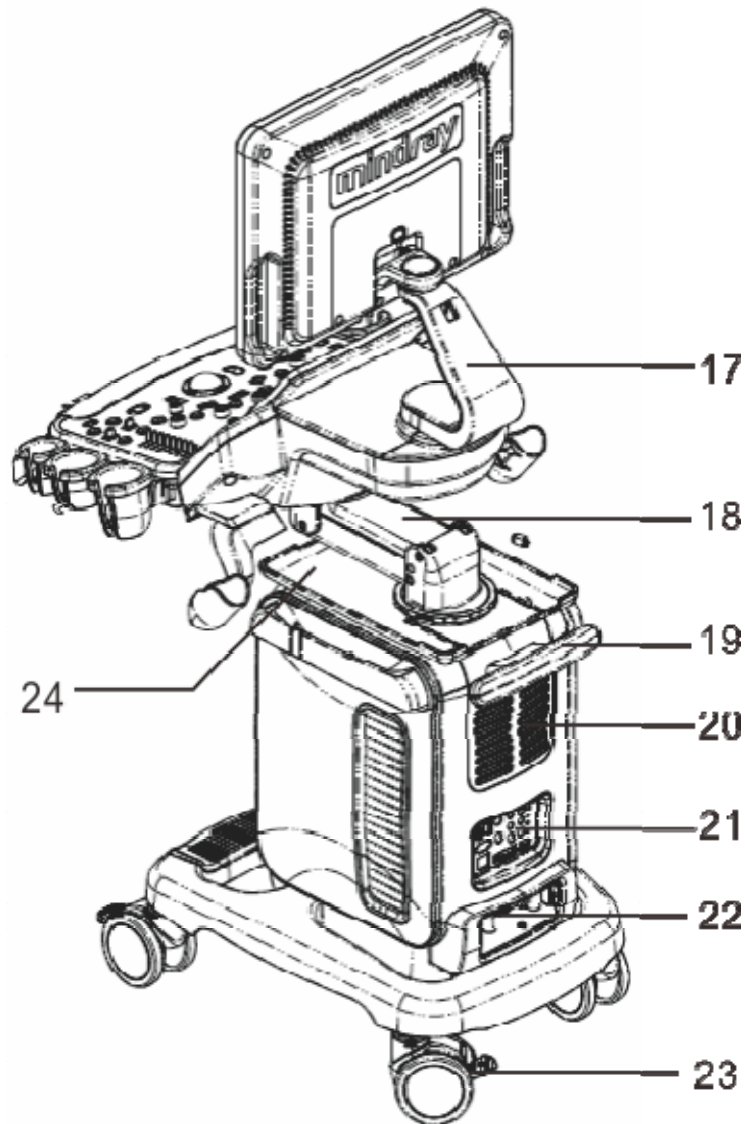

No.	Name	Function
1.	Monitor	Displays the images and parameters during scanning. (Support optional 15-inch or 17-inch monitor or 19-inch monitor)
2.	Speaker	Sound output.
3.	Touch screen panel	Operator-system interface or control.
4.	Ultrasound gel holder	Used for placing the ultrasound gel.
5.	Probe holder	Used for placing the general probe (not including pencil probe or intra-cavity probe).
6.	Pencil probe holder	Used for placing the pencil probe.
7.	Probe cable hook	Used for fixing the probe cable.
8.	Keyboard	Used for typing characters or entering some functions.
9.	Main control panel	Operator-system interface or control.

No.	Name	Function
10.	Control panel adjusting lever	Used for lifting or swiveling the control panel.
11.	USB	USB port
12.	Hanger	/
13.	Intracavitary probe holder	Used for fixing the intracavitary probe.
14.	Ultrasound gel holder/gel warmer	Used for placing the ultrasound gel or installing the gel warmer.
15.	Physio panel	Used for connecting the ECG leads and external ECG device.
16.	Probe port	Sockets connecting transducers and the main unit.
17.	Monitor supporting arm	Supports the monitor, for adjusting the height and position of the monitor.
18.	Control panel supporting arm	Supports the control panel, for adjusting the height of the panel.
19.	Rear handle	Used for pushing and moving the system.
20.	Cooling vent	/
21.	I/O Panel	Interface panel used for inputting and outputting signals.
22.	Power supply panel	Electrical port panel.
23.	Caster lock	Lock the caster. The device keeps stable when four casters are locked.
24.	Tray	Place the stuff or peripherals.

NOTE: Do not overexert to push down or lift up the control panel when operate the control table adjusting handle.

2.7 I/O Panel

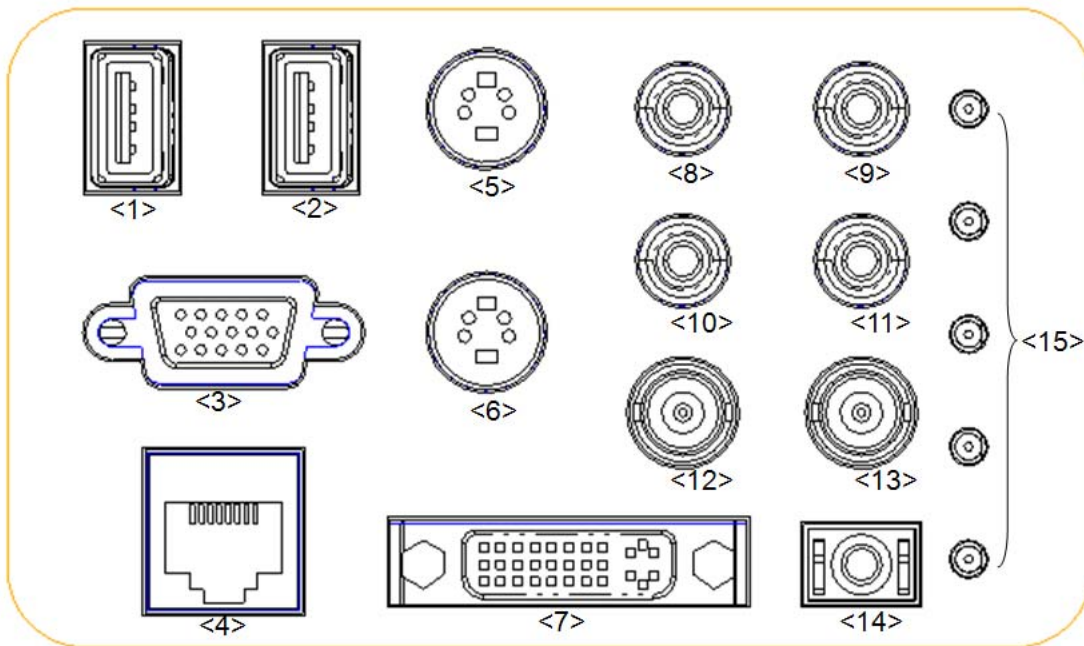

No.	Symbol	Function
<1><2>		USB port, used for connecting USB devices.
<3>		VGA signal output; connects a monitor or projector.
<4>		Ethernet interface.
<5>		Separate video input (reserved).
<6>		Separate video output.
<7>		DVI signal output.
<8><9>		Audio signal input port, left channel(reserved).
<10><11>		Audio signal output port, right channel.
<12>		Used for composite video input (reserved).
<13>		Used for composite video output.
<14>		Remote interface for connecting video printer.
<15>	Malfunction indication lights	Indicate the system's malfunction.

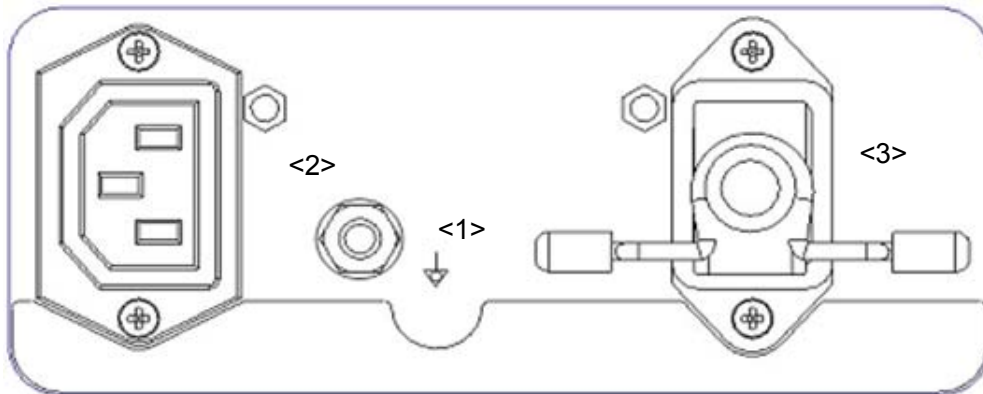

2.8 Power Supply Panel

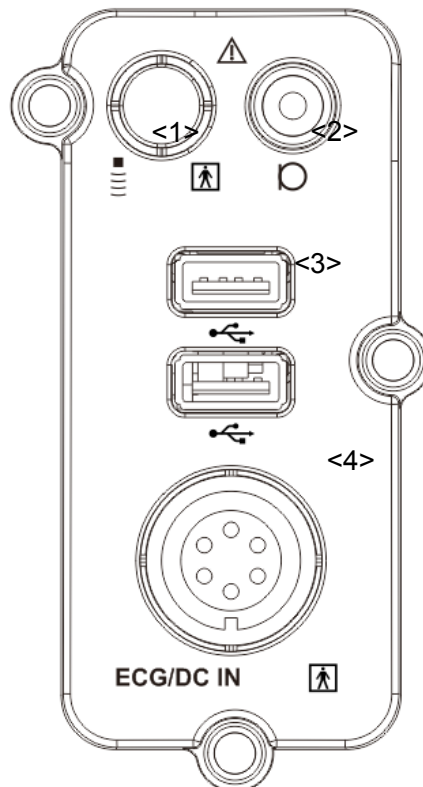

No.	Name	Function
<1>	Equipotential terminal ↓	Used for equipotential connection, balancing the protective earth potentials between the system and other electrical equipment.
<2>	AC Auxiliary Output	Power supply port for peripherals.
<3>	AC Input	AC power inlet.

2.9 Physiological-signal Panel







No.	Name	Function
<1>	Pencil probe port	Pencil probe port (reserved).
<2>	Mic In port 	Use for connecting microphone to record vocal comments (reserved)
<3>	Two USB ports 	Used for connecting USB devices.
<4>	ECG lead signal input port/external ECG signal input port	Connects to ECG leads, to directly obtain patient electrocardiosignal/used for connecting the signal output port of ECG monitor.

2.10 Control Panel



No.	English Name	Description
1.	/	Power button Press the button to turn on the system, the system enters the work status and the indicator becomes green.
2.	Volume	Adjust the volume.
3.	/	Adjust the corresponding functions on the touch screen.
	/	
	/	
	/	
	/	
4.	TGC	Slide to adjust the depth gain.

No.	English Name	Description
5.	Patient	Enter/exit Patient Info screen.
6.	Probe	Switch probe and exam mode.
7.	Review	Review the stored images.
8.	Report	Open/close the exam report.
9.	End Exam	End the current exam.
10.	Text	Enter/exit the textual comment status.
11.	Clear	Clear the comments or measurement caliper.
12.	Cine	Press to enter the Cine Review status from non-cine status when there is a multi-frame cine file playing.
13.	Body Mark	Enter/exit Body Mark.
14.	M	Press to enter M mode, and rotate to adjust M mode gain. While in 3D/4D mode, rotate the knob to make the 3D image to rotate around X-axis.
15.	CW	Enter CW mode.
16.	PW	Press to enter PW mode, and rotate to adjust PW or CW gain. While in 3D/4D mode, rotate the knob to make the 3D image rotate around Y-axis.
17.	Power	Enter Power mode.
18.	Color	Press to enter Color mode, and rotate to adjust Color or Power gain. While in 3D/4D mode, rotate the knob to make the 3D image rotate around Z-axis.
19.	Dual	Enter Dual mode in Non-Dual mode. Switch between the two display windows in the Dual mode.
20.	B	Press to enter B mode, and rotate to adjust B mode gain.
21.	Single	Enter single window in multiple window mode.
22.	4D	Press to enter 4D function and rotate to make the 3D image rotate.
23.	3D	Enter the 3D imaging function: Smart 3D or Static 3D.
24.	iTouch	Optimize the image.
25.	Angle/Steer	Adjust the angle. Adjust the steering of the probe.
26.	Measure	Enter/exit the application measurement mode.
27.	Update	Switching key: Press to change the currently active window. Start/stop image acquisition in iScape or 3D/4D mode.
28.	Caliper	Enter/exit the general measurement mode.
29.	Zoom	Rotate to enter the pan-zoom mode, and press to enter the spot-zoom mode.
30.	Quad	Enter Quad mode in Non-Quad mode. Switch between the four display windows in the Quad mode.
31.	Depth	Adjust the depth in real-time imaging.

No.	English Name	Description
32.	Focus	Change the focus position.
33.	Cursor	Show/hide the cursor.
34.	Set	Confirm an operation. The function is same with the left-button of the mouse.
35.	/	Move the trackball to change the cursor position.
36.	Set	Confirm an operation. The function is same with the left-button of the mouse.
37.	Freeze	Freeze/defreeze the image.
38.	Save	Save the image; user-defined key.
39.	P	User-defined keys, functions of which can be defined in preset.
40.	Print	Print: user-defined key.
41.		<p>Battery status indicator.</p> <ul style="list-style-type: none"> ■ Charging status: It illuminates in green when batteries are charged fully. ■ Discharging status: It illuminates in green color when the power of the batteries is more than 20%; It illuminates in orange color for low battery power.
		<p>AC indicator</p> <p>The indicator is on at AC supply.</p>
		<p>Standby indicator.</p> <p>Standby: blinking in orange.</p>
		<p>Hard disk status indicator.</p> <p>The indicator blinks in green when hard disk is running.</p>

NOTE: “/” means the key are undefined or have no silk print. For the undefined keys, you can customize them.

Keyboard

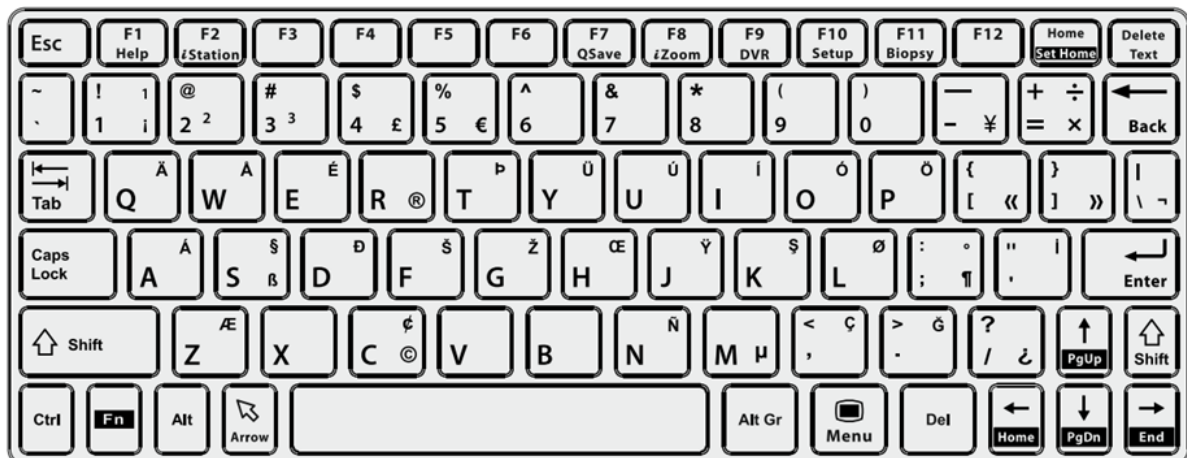

■ Common functional keys

No.	Key	Function
1.	Enter	Confirm the entered data, or move the cursor to the top of the next row of the text or input field.
2.	Esc	Cancel the operation or exit.
3.	Tab	Jump to the next operable item.
4.	Back space	Insert a space.
5.	Caps Lock	Switch between upper/lowercase.
6.	Home	Activate the Home function: return to start position of the comment.
7.	Delete Text	Delete all comments on the screen.
8.	Direction-control keys	Move the cursor one letter each time, or, select the surrounding objects in the selectable area.
9.	Del	Delete the character after the cursor
10.	Back Space	Delete the character before the cursor

■ Functions of the F1 to F12 keys

No.	Key	Function
1	F1 Help	Open or close the accompanying help documents.
2	F2 iStation	Enter or exit the Patient Info system.
3	F3~F6	User-defined keys, the functions of which can be preset.
4	F7 QSave	Save the current image parameters quickly.
5	F8 iZoom	Enter/exit full-screen zoom status.
6	F9 DVR	Reserved, enter/exit DVR mode.
7	F10 Setup	Enter/exit Setup.
8	F11 Biopsy	Display/hide the guide line.
9	F12	User-defined keys, the functions of which can be preset.

■ Functions of key combinations

The system supports multi-language input using key combinations. Key combinations include [Shift], [Alt Gr], [Ctrl], [Fn] and some alphabet keys. For details about switching the system to multi-language, see “12.1.1 Region” for details.

























- <Shift> key
 <Shift> + key: enter the top left letter on the key.
 For the alphabet keys (<A>~<Z>), press <Shift> + key to enter the current letter in a different case.
- [Alt Gr] key
 Combined with other letter keys, [Alt Gr] can be used for entering other languages. Press [Alt Gr] and a letter key simultaneously. The letter in the top-right corner of the key is entered.
- [Ctrl] key combined keys
 On the iStation or Review screen, use <Ctrl> and <Set> to select more than one patient or more than one image.
- [Fn] key

For these combination keys, press <Fn> + key to use the functions indicated with a frame on the key.

No.	Fn+	Name	Function
1.	→	End	Move the cursor to the end of the row, or the rightmost side of an editable unit.
2.	←	Home	Home
3.	↑	Pg Up	Turn pages upward.
4.	↓	Pg Dw	Turn pages downward.
5.	Home	Set Home	Activate the Set Home function: set the start point of a comment.

2.11 Symbols

This system uses the symbols listed in the following table, and their meanings are explained as well.

No.	Symbol	Description	
1		Type-BF applied part	
2		Caution	
3		AC (Alternating current)	
4		Equipotentiality	
5		Power button	
6		Foot switch	
7		Transducer sockets	
8		Network port	
9		USB port	
10	VGA 	Used for VGA output.	
11	S-VIDEO		Reserved, used for separate video output
			Separate video input, reserved.
12	DVI-D 	DVI-D signal output	
13	AUDIO		Used for stereo audio output
14			Used for stereo audio input
15		Battery Status Indicator	
16		Hard disk status indicator	
17		Standby status indicator	
18		AC power supply status indicator	
19		Microphone input jack	
20		Dangerous voltage	
21		Product serial number	
22		Manufacture date	
23		Authorized representative in the European Community	

3 System Preparation

-  **WARNING:**
1. Do not connect the three-wire cable of the system with a two-wire plug without protective grounding; otherwise, electric shock may result.
 2. Do not connect the power plug of this system to wall receptacles that meet the ratings indicated on the rating nameplate. If adapters or multifunctional receptacles are used, it may cause the leakage current to exceed the safety requirement.
 3. In the environment that patient is 1.5 meters around, connect peripherals to the auxiliary power outlet which is capable of isolation protection, or power the peripherals by auxiliary output cable or isolation transformer complied with IEC 60601-1-1 or the power input of the same safety level.
 4. **DO NOT** use power supply of different phases to power peripherals.
 5. When using peripherals not powered by the auxiliary output of the ultrasound system, or using peripherals other than permitted by Mindray, make sure the overall leakage current of peripherals and the ultrasound system meets the requirement of the local medical device electrical regulation (like enclosure leakage current should be no more than 500uA of IEC 60601-1-1), and the responsibility is held by the user.

3.1 Move/Posit the System

Please read and understand the safety precautions before placing the system to ensure safety for both operator and device.

1. Switch off the power, unplug the power cord.
2. Disconnect all cables from the off-board peripheral devices (printer, recorder, etc.).
3. Release the four casters, and move the system by holding the handle.
4. When you move the system to a desired location, lock the four casters.
5. Leave at least 20cm at the back and both sides of the system.

-  **CAUTION:**
1. Maintain a generous – free air flowing space around the back and both sides of the system; failure may result due to increased rise in system operating temperature.
 2. Pay extra attention when moving the system on a sloping ground, **DO NOT** move it on a more than 10°-sloped plane to avoid system toppling.

3.2 Power Supply

This system can work normally only when it is connected to the external power supply or the battery capacity is sufficient.

3.2.1 Connecting AC Power Supply

The connection method is described as follows:

1. Push the retaining clamp upward, and insert the power plug into the receptacle, as shown in the figure below.

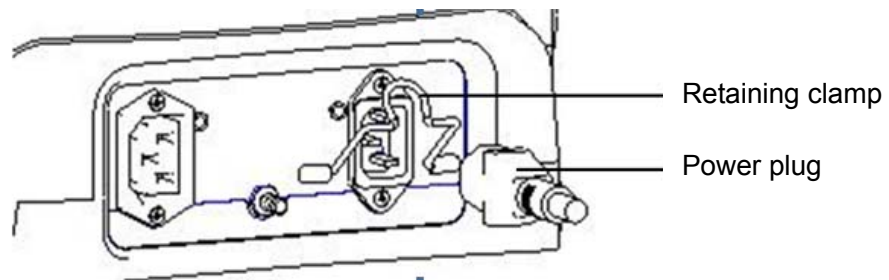

2. Push the retaining clamp downward, and lock the power cord, as shown in the figure below.

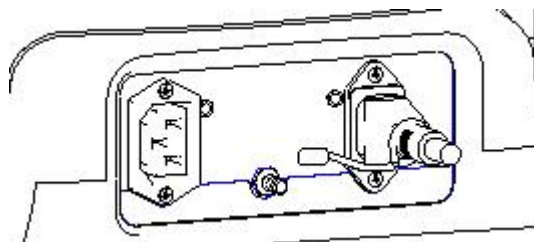

3. Plug the other end power plug into an appropriate power socket. The grounding terminal should be connected with a power grounding cable to ensure that protective grounding works normally.

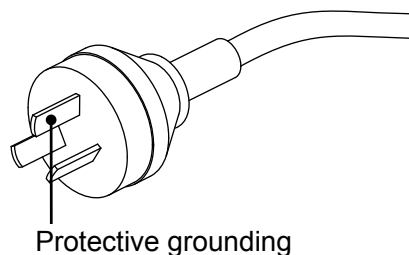



NOTE: Make sure to allow sufficient slack in the cable so that the plug will not be pulled out from the socket even if the system is moved slightly. If the plug is pulled out accidentally, data may be lost.

3.2.2 Powered by Batteries

- When connected to the external AC power supply, the system is powered by the external power. The lithium ion batteries inside it are in the charging status.
- When disconnected from the external power supply, the system is powered by the lithium ion batteries. Refer to Chapter 15 for the detailed operations and precautions.

3.2.3 Equipotential Terminal

The symbol  represents the equipotential terminal that is used for balancing the protective earth potentials between the system and other electrical equipment. For the equipotential terminal location, please refer to “2.8 Power Supply Panel”.

 WARNING:	<ol style="list-style-type: none">1. Be sure to connect the equipotential wire before inserting the power plug into the receptacle; be sure to remove the power plug from the receptacle before disconnecting the equipotential wire; otherwise electric shock may result.2. When you connect another device to this system, you should use the equipotential wire to connect each of equipotential terminals; otherwise electric shock may result.3. Connect the earth cable before turning ON the system. Disconnect the earth cable after turning OFF the system. Otherwise, electric shock may result.4. DO NOT connect this system to the outlets with the same circuit breakers and fuses that control the current to devices such as life-support systems. If this system malfunctions and generates over-current, or when there is an instantaneous current at power ON, the circuit breakers and fuses of the building's supply circuit may be tripped.
---	---

3.3 Power ON/OFF

3.3.1 Powering ON the System

 CAUTION:	<p>To ensure safe and effective system operation, you must perform daily maintenance and checks.</p> <p>If the system begins to function improperly – immediately stop scanning. If the system continues to function improperly – fully shut down the system and contact Mindray Customer Service Department or sales representative.</p> <p>If you use the system in a persistent improperly functioning state – you may harm the patient or damage the equipment.</p>
---	---

■ Checking before Power ON

To check the system before the system is turned on:

No.	Check Item
<1>	The temperature, relative humidity and atmospheric pressure shall meet the requirements of operating conditions. See "2.4.3 Environmental Conditions" for details.
<2>	There shall be no condensation.
<3>	There shall be no distortion, damage or dirt on the system and peripheral devices. If any dirt is found, cleaning shall be performed as defined in section "16 System Maintenance".
<4>	There shall be no loose screws on the monitor or control panel.
<5>	There shall be no cable damage (e.g. power cord). Maintaining secure connections to the system at all times.
<6>	The probes and probe cables shall be free of damage or stains. See "13.1.5 Probes Cleaning and Disinfection" for details on probe cleaning and disinfection.
<7>	No miscellaneous odds and ends are allowed to be attached or affixed to the control panel.
<8>	Ensure that all connections are free from damage and remain clear of foreign object blockages. There shall be no obstacles around the system and its air vent.
<9>	Probe cleaning and disinfection. (Please refer to "13 Probes and Biopsy" for details).
<10>	The overall scanning environment and field must be clean.
<11>	The locking mechanism of casters can work normally.

■ Turning on the Power

To turn on the system:

- (1) Press the power button  in the upper left corner on the control panel.
- (2) The system enters the work status.

When the battery capacity is sufficient, you can also press the power button  directly to turn on the system.

To check the system after the system is turned on:

No.	Check Item
<1>	There shall be no unusual sounds or smells indicating possible overheating.
<2>	There shall be no persistently displayed system error message.
<3>	There shall be no evident excessive noise, discontinuous, absent or black artifacts in the B mode image.
<4>	Check if there is abnormal heat on the surface of the probe during an ultrasound procedure.

No.	Check Item
<5>	The control panel keys and knobs are fully functional.
<6>	The touch screen and the main monitor screens display normally depending on the system modes and image status.
<7>	The exam date and time are the same as the system date and time, and are displayed correctly.



WARNING: If you use a probe giving off excessive heat, it may burn the patient.

If you find anything not functioning properly, this may indicate that the system is defective. In this case, shut down the system immediately and contact Mindray Customer Service Department or sales representative.

3.3.2 Powering OFF the System

You need to follow the correct procedures to power off the system. In addition, after you upgrade the software or when the system is down, you need to power off and restart it.

If you will not use the system for a long period of time, you shall:

1. Disconnect the mains power.
 2. Turn off powers of all peripherals connected to the system.
- To power off your system normally:



Gently press the power button  once on the upper left corner of the control panel. The Shutdown Confirm screen appears.

- Shut down: To power off the system normally.
 - Standby: Click to enter the standby status. Press the power button to turn on the system.
 - Cancel: To cancel the operation.
- To shut down the system in a direct way if you cannot do it normally:

Long press the power button and the system will power off without displaying the [Shutdown Confirm] screen. However, shutting down the system in this way may destroy the data.

- NOTE:**
1. DO NOT rush shutdown of the system in a direct way. It may destroy the data.
 2. After the software upgrade, please shut down the system in the normal way (using “Shut down” method) so as to guarantee a fully update.

3.3.3 Standby

When the battery capacity is charged to the full capacity, the standby time of the system is no less than 24 hours.

- To enter standby:
 - Open [Setup]→[System Preset]→[General] to set the time for screensaver and standby mode. If there is no operation, the system enters screensaver after the

waiting time set for screensaver, and if there is still no operation, the system enters standby after the waiting time for standby.

- Press the power button and select “Standby”.
- Disconnect the power plug, and select “Standby” in the prompted dialogue box. When the system enters the standby status, the standby status indicator blinks in orange.
- To exit standby
 - Press the power button.
- When the system enters the standby status, if need to power off:
 - Long press the power button for 5s.
 - Press the power button to exit the standby status and then power off the system.

NOTE:

1. Power off the system if you will not use the system for a long period of time (including storage/ transportation conditions), and you should not allow the system in standby status, otherwise the batteries will be out of power and permanently damaged.
2. If you will not use the system for a long period of time, DO NOT leave the system in standby status, you should shut down the system, disconnect mains power, and turn off powers of all connected peripherals.

3.4 Monitor Adjusting

3.4.1 Monitor Position Adjusting

Gently hold the bottom edge of the monitor when adjusting its position.

- Rotate the monitor
 - Monitor rotationThe monitor can be rotated $\pm 90^\circ$.

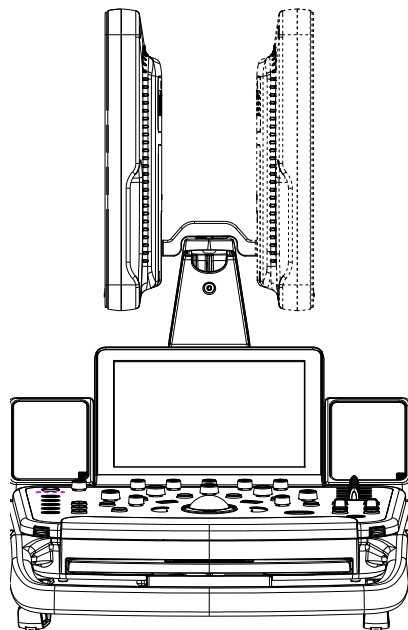

- Tilt the monitor

When positioned vertically, the monitor can be tilted 20° backward and can be tilted forward to a horizontal position. When transporting or moving the system, keep the monitor in the horizontal position, as shown below:

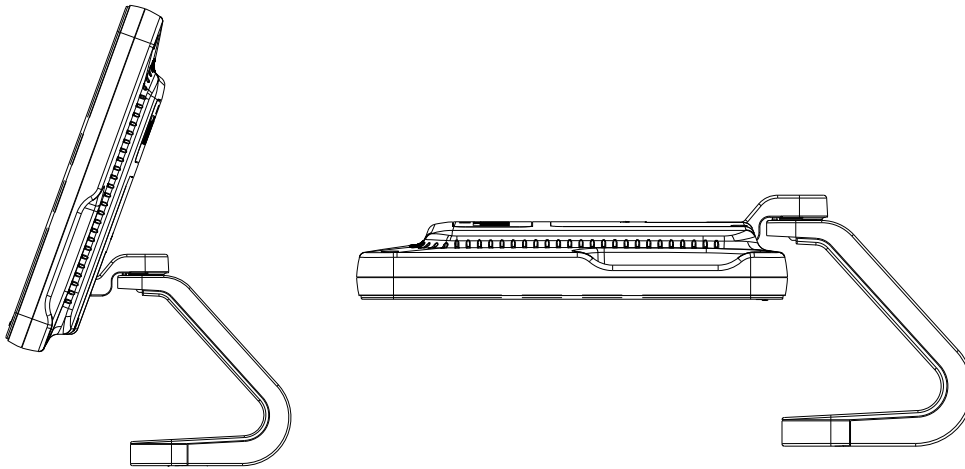

3.4.2 Adjusting Brightness/Contrast on the Monitor

Monitoring the brightness and contrast adjustment is one of the most important factors for proper image qualities. If set incorrectly, the gain, TGC, dynamic range or even acoustic output have to be changed more often than necessary to compensate.

The adjusting buttons are shown as follows:

- Brightness adjustment:

<1>, <2> refer to the brightness control keys with a sun marked at the top. Key <1>, marked with a “-” on the top, can be used to decrease the brightness, while key <2>, marked with a “+” on the top, can be used to increase the brightness.

- Contrast adjustment:

<3>, <4> refer to the contrast control keys with a moon marked at the top. Key <3>, marked with a “-” on the top, can be used to decrease the contrast, while key <4>, marked with a “+” on the top, can be used to increase the contrast.

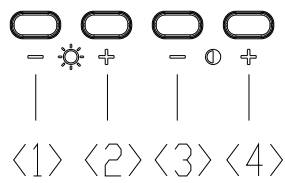
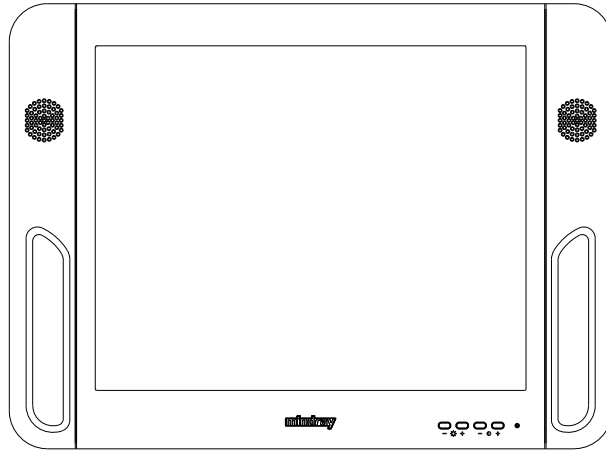

NOTE: On the monitor, the brightness adjustment comes before contrast. After readjusting the monitor's contrast and brightness, adjust all preset and peripheral settings.

3.4.3 Control Panel Position Adjustment

Press the control lever downwards for about 30° to rotate the control panel ±90°. Press the lever downwards for about 60° to move the control panel upwards or downwards.

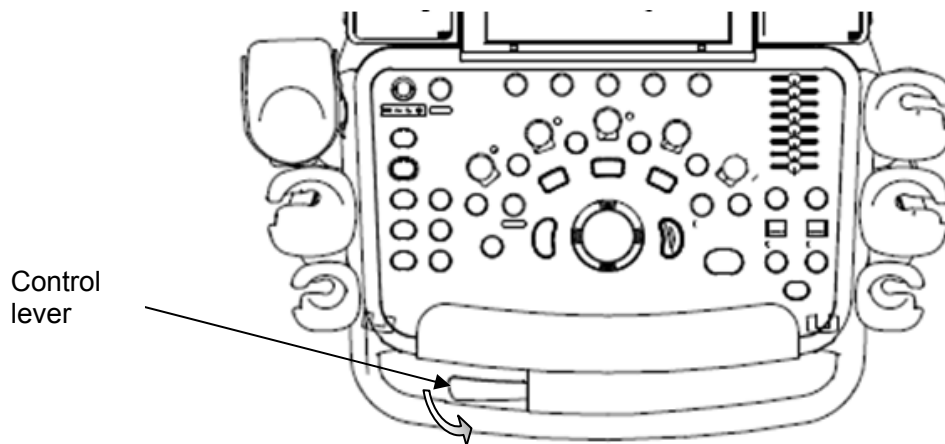

3.5 Connecting a Probe

- CAUTION:**
1. Press <Freeze> to freeze an image or turn off the power of the system before connecting/disconnecting the probe. Otherwise, system or probe failure may occur.
 2. When connecting or disconnecting a probe, place it in a proper position, to prevent the probe from falling off or becoming damaged.
 3. Hang the probe cable to the hanger located under the control panel to avoid excessively bending and damaging the cable.
 4. Only use the probes provided by Mindray. Aftermarket probes may result in damage or cause a fire.

NOTE: If a probe port is not used for a long period of time, please use the dustproof cover to protect the probe port from dust; otherwise bad contact may result.

3.5.1 Connecting a Probe

WARNING: The probes, cables and connectors should be in proper operating order and free from surface defects, cracks and peeling. Otherwise, this may lead to electrical shock.

1. Keep the cable end of the transducer to the right side of the system, insert the connector into the system port, then press in fully. (Shown in the left figure)
2. Turn the lock handle 90° clockwise to lock it securely. (Shown in the right figure)
3. Position the probe properly to avoid it being treaded on or becoming wrapped around other devices. DO NOT allow the probe head to hang free.

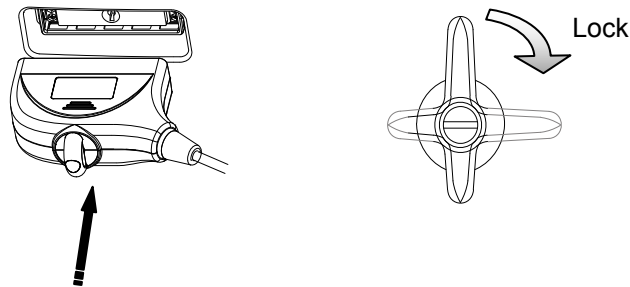

NOTE: Before inserting the connector into the probe port, inspect the connector pin. If the pin is bent, do not use the probe until it has been inspected/repaired/replaced.

3.5.2 Disconnecting a probe

1. Turn the locking lever 90° counterclockwise to the vertical position. (Shown in the left figure)
2. Pull the transducer connector straight out vertically (shown in the figure below).

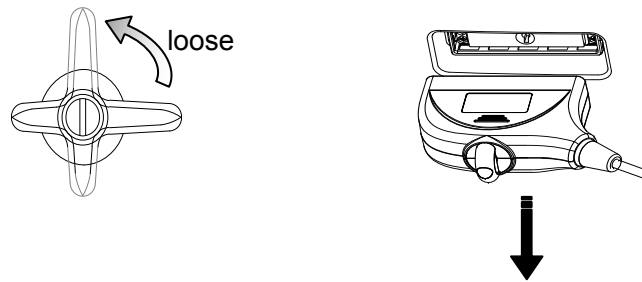



3.6 Connecting Peripheral Devices

3.6.1 Connecting the USB Devices

WARNING: DO NOT directly remove a USB memory device; otherwise, the USB memory device and/or the system may be damaged.

Available USB ports on the system:

1. Two USB ports on the physiological-signal panel.
 2. Two USB ports on the I/O panel at the back of the system.
 3. Two USB ports on the control panel.
 4. One USB port in the printer room, which is dedicated for digital video printer.
- When connecting a USB memory device to the ultrasound system via a USB port, you can hear a sound if it is connected successfully. You can see the symbol  in the lower right corner of the imaging screen.
 - To remove the USB memory device:
 - (1) Click  to open the "Remove USB Device" dialogue box.
 - (2) Select the memory device to be removed.
 - (3) Click [OK] and you can hear a sound. There will be sound feedback when remove the USB memory device.

3.6.2 Connecting a Footswitch

- Connection
Directly insert the USB port of the footswitch to the system applicable USB ports.

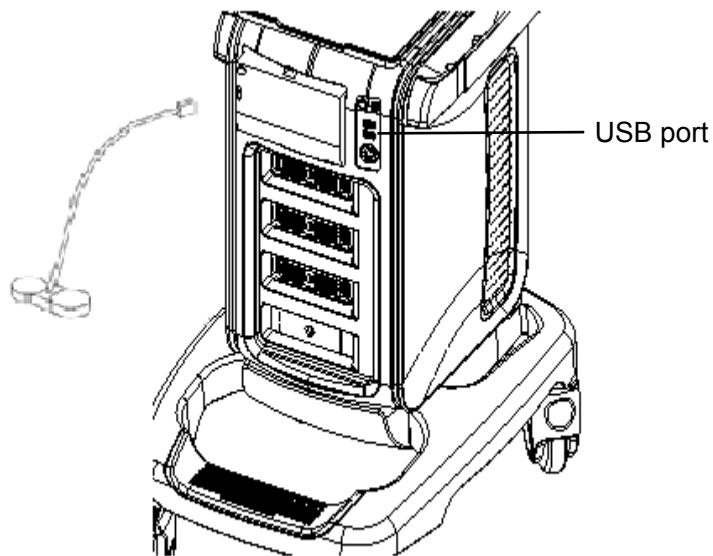

■ Function setting

The function of the footswitch can be set, for details, please refer to “12.1.6 Key Configuration”.

3.6.3 Graph /Text printer

3.6.3.1 Connecting a Local Printer

As shown in the figure below, a graph / text printer has a power cord and data cable. The power cord shall be directly connected to a wall receptacle as required.

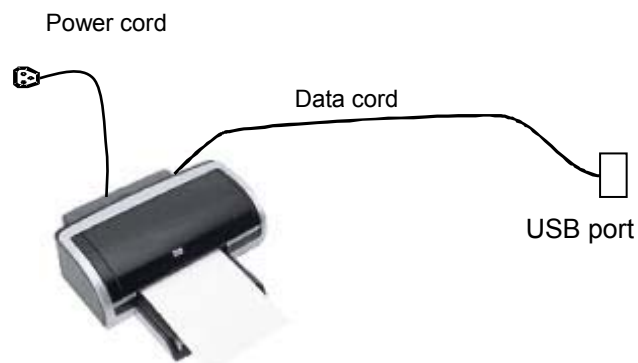

1. Connect the data cable with the USB port on the ultrasound system.
2. Plug the other end power plug into an appropriate outlet.
3. Power on the system and the printer.
4. Check the printer status:
 - Enter [Setup]→[Print Preset]→“Printer Driver” page, printers that are installed automatically will be displayed in the list with the “Status” of “Ready”.

Service Name	Service Type	Printer	Status
Report Print	Report Print		Fail to open
Digital Print	Digital Image Print	Sony-UP-D897	Fail to open
Analog Print	Analog Image Print	Black and White P...	N/A

5. Return to “Print Service” page, and select “Report Print” in the list, and set attributes in the Property box under the screen:
 - Select the printer model from the drop-down list right to the “Printer”;
 - Set Paper Size.

6. Click [Save] to finish the installation.

Tips: Drivers of some popular printers have already been integrated in the system, and will be installed automatically. You need to check the following information to check if the auto-installation fails:

- Model of the connected printer is not displayed in the “Printer Driver” list;
- Click “Printer Driver”→[Add Printer]→[Add Local Printer], the system will prompts you to update the ppd file.

At this time, you need to install the printer driver manually as described in the following:

- a) Download the ppd file from the printer manufacturer's official website (contact service engineer if necessary), and copy the ppd file to the storage device (USB disk as an example).
- b) Connect the USB disk to the ultrasound system, click [Setup]→[Print Preset]→"Printer Driver"→[Add Printer] to run the ppd file and finish the installation.

NOTE: All printer drivers integrated in the ultrasound system come from official website of each printer manufacturer (you can check models in the [Setup]→[Print Preset]→"Printer Driver"→[Printer Supported]).Printer drivers may not be updated in time due to software version and region limitation, consult printer manufacturer for details.

3.6.3.2 Add Network Printer

1. Make sure the target network printer and the ultrasound system are both connected into the same LAN.
2. Check the IP address of the network printer (for details, please refer to the accompanying documents of the printer).
3. Enter [Setup]→[Print Preset]→"Printer Driver" page, click [Add Printer] to enter the screen, type in the IP address of the network printer. (Port is 9100 in default).
4. Click [Verify Net Printer], the IP address, name and port information of the network printer will be displayed under the "Port" box. Change the port to match the verified printer information if necessary.
5. Click [OK] to enter the ppd installing screen:
 - Select PPD file from media: select the path from the external media and install.
 - Select PPD file from database: select the ppd. file integrated in the ultrasound system.
6. After the ppd. file is installed completely, enter the printer name to finish the installation.
7. After installation succeeds, the system returns to the "Printer Driver" page and displays the added network printer.

3.6.3.3 Installing a Wireless Printer

The system supports wireless graph/text printer for report printing.

1. Plug the printer power cord into an appropriate outlet.
2. Power the system and the printer on.
3. Make sure the ultrasound machine and the printer are connected to the same LAN, and turn the printer's W-LAN function on.
4. Add a wireless adapter, following the steps described in "Add network printer."
5. Open the [Setup]→[Print Preset] page, select "Report Print" from the printer list, select the printer to be the wireless printer, and set properties.
6. Click [Save] to exit the preset and make the settings effective.

3.6.3.4 iStorage UltraAssist Print

The system supports printing by iStorage function. Before using this function, please make sure that the iStorage server has configured a defaulted printer, and the ultrasound system has configured an iStorage server. For details, please refer to "12.5.2 iStorage".

1. Enter [Setup]→[Print Preset]→"Printer Driver" and check iStorage printer status, which should be AssistPrinter@IP address with "Ready" status.

2. Click "Print Service" to enter the screen, and select AssistPrinter@IP address to be the printer for the Report Print service.
3. Verify the status of the network connection.

Click the [Ping] button in the [Status] column of the iStorage printer list, and the system pops a dialog box to display whether the connection with the iStorage server is ready or not.

NOTE: Check if the iStorage printer is well connected with the server when the printing fails with the verification result being Ready,

4. Click [Save] .

3.6.3.5 Print Service

You can use a graph/ text printer to print report or images.

- To set the default report printer and its attribute:
In "[Setup]→[Print Preset]" screen, select the "Print Service", select "Report Print" column in the service list, set the items in the "Property" box.
- Report print:
Click [Print] in the report dialog box to print a report; or, use the user-defined key to print, see "12.1.6 Key Configuration" for details. Please refer to the accompanying manuals of the printers for more details.

3.6.4 Installing Analog Video Printer

1. Plug the printer power cord to an appropriate outlet.
2. Put the printer in a proper place.
3. Cable connection:

- B / W analog video printer

The printer compartment under the control panel provides the following cables:

- (1) power cord;
- (2) USB cable (used for connecting digital video printer);
- (3) video signal cable;
- (4) Remote control cable, as shown in the figure.

Connect the remote cable to the remote port of the printer, and video signal cable to VIDEO IN port of the printer.

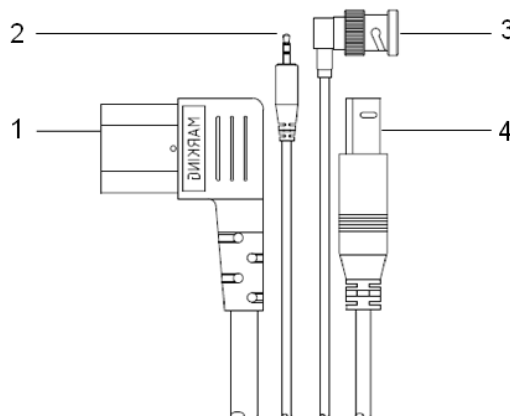

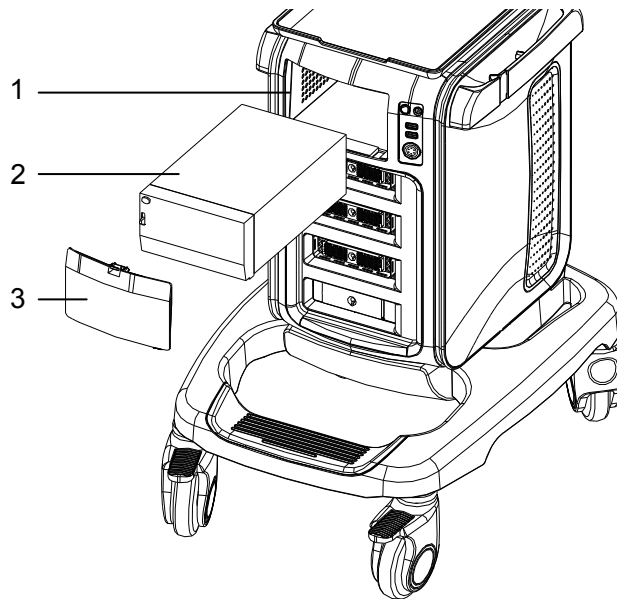

1. Printer room window 2. Printer 3. Room cover

- Color analog video printer: use the I/O panel at the rear side of the machine to connect the printer, as shown in the following figure:

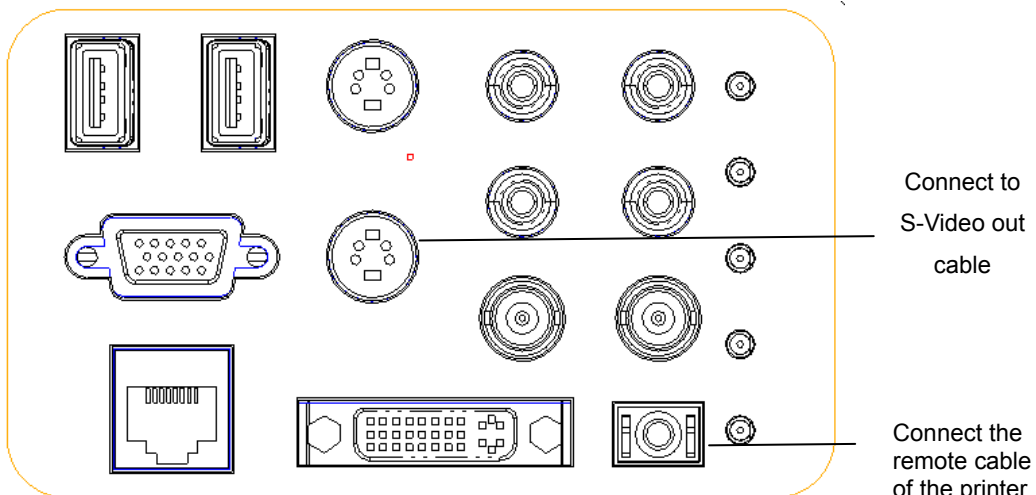

4. Load a paper roll, and turn on the system and printer.
5. Modify print service:
 - Add a print service:
 - (1) Open the [Setup]→[Print Preset]→[Print Service].
 - (2) Click [Add Service] to enter the page.
 - (3) Select the service type and enter the service name manually.
 - (4) Click [OK] to return to the Printer Service page.
 - (5) Select the printer model, and then you can set the properties in the Property box.
 - (6) Click [OK] to complete the setting.
 - Modify print service:
 - (1) Select an existed printer service in the list.
 - (2) Select the printer model, and then you can set the properties in the Property box.
 - (3) Click [OK] to complete the setting.

3.6.5 Installing Digital Video Printer

1. Put the printer in a proper place.
2. Plug the printer power cord to an appropriate outlet.
3. Use a USB cable to connect between the USB port of the system and the USB port of the printer.
4. Load a paper roll, and turn on the system and printer.
5. See section “3.6.3 Graph /Text printer” for driver installation procedure (drivers of printers listed in the “2.5.4 Peripherals Supported” chapter are installed already).
 - Add a print service:
 - (1) Open the [Setup]→[Print Preset]→[Print Service] screen.
 - (2) Click [Add Service] to enter the Print Service page.
 - (3) Select the service type and enter the service name manually.
 - (4) Click OK to return to the Printer Service page.
 - (5) Set printing properties.
 - (6) Click [OK] to complete the setting.
 - Modify print service:
 - (1) Select an existed printer service in the list.
 - (2) Select the printer model, and then you can set the properties in the Property box.
 - (3) Click [OK] to complete the setting.

3.6.6 Installing a Wireless Printer

The system supports wireless graph/text printer for report printing.

1. Plug the printer power cord into an appropriate outlet.
2. Power the system and the printer on.
3. Make sure the ultrasound machine and the printer are connected to the same LAN, and turn the printer's W-LAN function on.
4. Add a wireless adapter, following the steps described in “Add network printer.” See chapter “3.6.3 Graph /Text printer” for details.
5. Open the [Setup]→[Print] page, select “Report Print” from the printer list, select the printer to be the wireless printer, and set properties.
6. Click [Save] to exit the preset and make the settings effective.

3.6.7 Installing/ uninstalling Probe/Gel Holder

■ Installing

As shown in the figure below, align the buckle of the holder to the slot at the side of the control panel and then insert the buckle into the slot until the buckle clicks and locks.

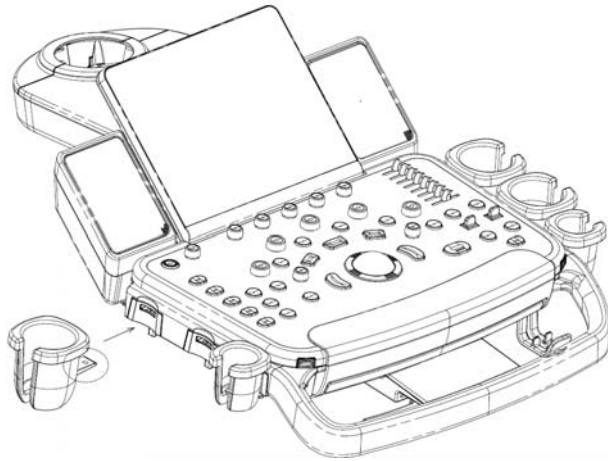

■ Uninstalling

Press the clip in the direction of the arrow to get out the holder.

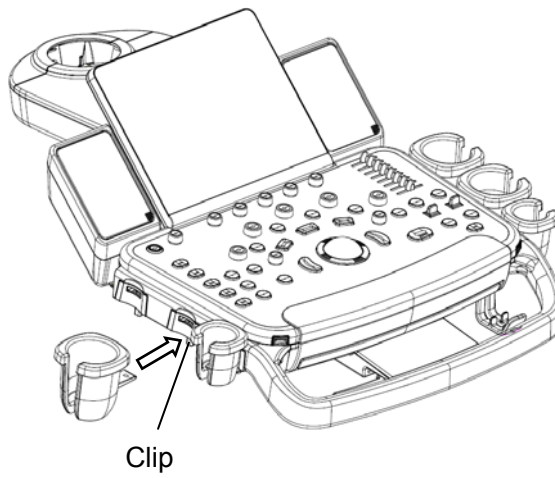

3.7 Basic Screen and Operation

3.7.1 Basic Screen

The following diagram maps out the different areas in the screen:

Menu/exam mode/image parameter	Logo	Hospital name			Patient name	Accession#	Freeze icon
		Operator	ID	DOB/age	Gender	Exam date&time	Thumbnails
	Probe&acoustic power						
	Image area						
Image-in-image Thumbnail	ECG trace						Image manage
	Cine Review						
Soft menu			Tips		Soft menu		
Help Information					System Icon		

■ Information Area

The information area displays manufacturer logo, hospital name, exam date & time, operator, probe, acoustic power & MI/TIS, freeze icon, patient information, ECG icon (if ECG module is configured), and accession #, etc.

To preset the patient banner display content: open the [Setup]→[System Preset]→[General] screen, and check the content in the “Patient Info” box in the upper left corner of the screen.

● Logo

Manufacture logo, displayed in the upper left corner of the screen.

- Hospital name
Display the hospital name. Hospital name can be set via "[Setup]→[System Preset]→[Region]".
 - Exam time
Displays the exam time, including date and time. Exam time format can be set via "[Setup]→[System Preset]→[Region]". Exam time will be frozen with the frozen image.
 - Probe model
Displays the currently-used probe model, or the default model.
 - Acoustic power & MI/TIS
Displays the acoustic power, including the acoustic power, MI (Mechanical Index) and TIS.
 - Freeze icon
The freeze icon  means the image is frozen.
 - Patient Information
Displays patient name, ID, gender and age etc. Enter the patient information through the "Patient Info" screen. Or, import the registered patient data from iStation or the DICOM Worklist server.
 - Operator
Displays the operator's name on the screen. This information is entered through the "Patient Info" screen.
 - ECG icon
Displays ECG icon, which consists of a heart icon and heart rate, e.g. "♥75bpm"
 - Accession#
Serial number used in DICOM or the manually entered serial number in "Patient Info" screen.
- Image Parameter and Menu Area
- The image parameter and menu are both displayed in this area. When no menu is available; this area displays the image parameters of the current imaging mode. Current exam mode is also displayed here.
- Menu area
When an image menu is displayed, the imaging parameters will be covered by the menu.

Include image menu, measurement menu, comment menu, body mark menu and so on. Use the trackball to operate on the menu.

Use the <Menu> to show or hide the menu.

The menu area consists of menu title, menu items, etc. As shown in figure below.

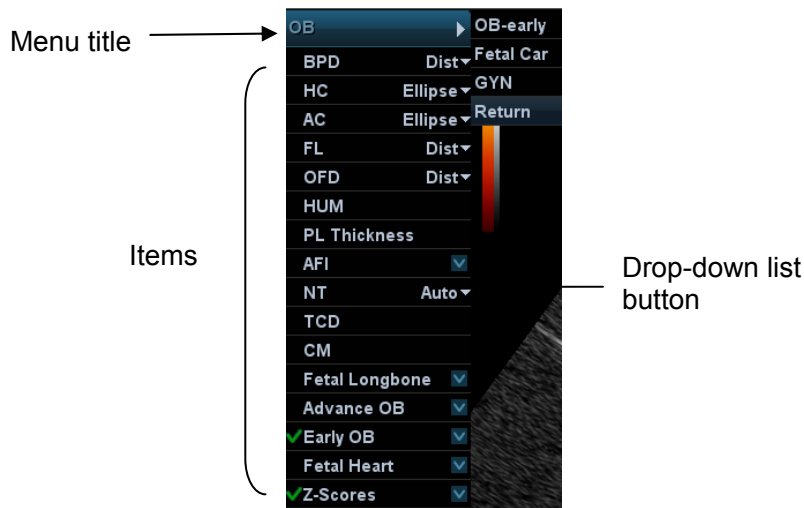

- Menu title
Displays the menu name.
- Items
Refers to the items on a menu. For item that is applicable for more than one mode, the item appears as shared item in the certain mode. Items of image modes and measurement can be preset.
- Down-drop list button
If there are several options available for one item, you can choose the options through the  button.
- Return to previous menu
Click [Return] to return to the previous menu.

■ Parameter Area

Displays the image parameters for the activated image window. If there are more than one imaging modes, the system displays the parameters of each image mode respectively. For details, please refer to the corresponding imaging mode(s).

■ Image area

The image area displays the ultrasound images, ECG waveforms, probe mark (or activating window mark), time line (in M or PW mode), coordinate axis (including depth, time, velocity/frequency), focal position (located at depth axis in the form of ) , besides, the annotation, body mark, measurement calipers, color bar/grayscale bar are also displayed here.

■ Image-in-Image thumbnail area

In the zoom status, this area displays the thumbnail of a complete image, and a rectangular frame is used to highlight the currently magnified area. This feature is called image-in-image.

■ Cursor area





The status icon area indicates the current cursor status, such as  in cineloop status.

■ Help information area

The help information area displays various help information or progress bar in the current status.

■ Thumbnail area of images stored

Displays the thumbnail images stored under the current patient.

- Image manage area
 - Page up/down: when there are more than one page images have been stored, you can turn to the next or preview page by  or  respectively.
 - Delete: select a thumbnail image, and click  to delete it.
 - Send to: select a thumbnail image, and click  to send it to external devices.
- Soft Menu area

The monitor's soft menu area displays the items that simultaneously appear at the bottom of the touch screen.
- System status area

This area displays the relevant system icons, such as USB memory device, printer, network connection, and current system time, etc.
- None-fixing Area

Areas illustrated here are position-changeable; you can move them by the trackball within a certain area on the monitor.

 - Result window

The measurement result window displays the results of recently performed measurements.

To move the result window:

 - a) Place the cursor on the title of result window (you can see the cursor changes into .
 - b) Press <Set> and move the trackball, the window moves together with the cursor.
 - c) Move the cursor to the target position, press <Set> again to anchor the result window in the target position.
 - Comment area

For details, please refer to “9 Comments and Body Marks”.
 - Body mark area

For details, please refer to “9 Comments and Body Marks”.

3.7.2 Basic Operations of Screens

A screen consists of title, page tabs, contents and buttons, as shown in the following figure:

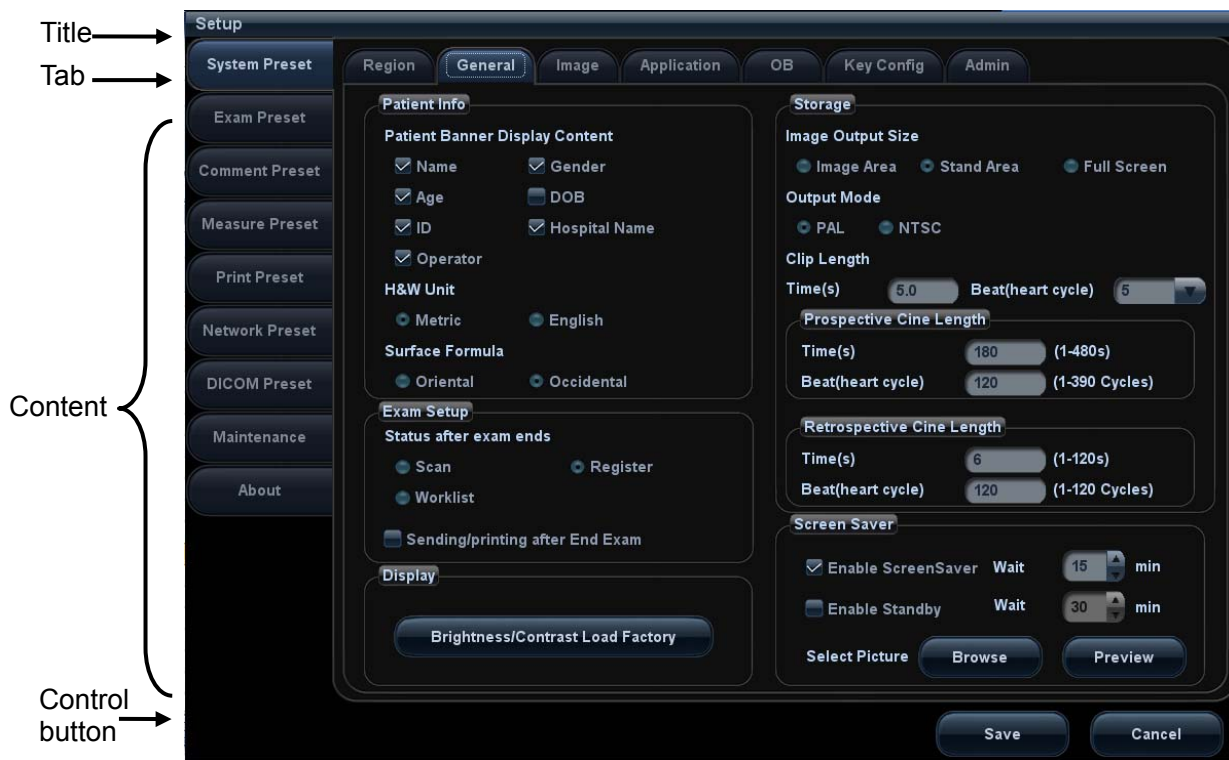

Composition	Description
Title Bar	The title bar is used to give a description for the content and function of the screen.
Page Tab	For some screens, contents are distributed across several pages. Click the tab by pressing <Set> key to open/close the available pages.
Contents	<ul style="list-style-type: none"> ■ Radio button: click to select the item. ■ Check box: click to check or uncheck the item. ■ Entry box: enter characters manually via the keyboard. Position the cursor into the box, and then enter the letters or characters. ■ Drop-down list box: click “▼” to show the list and select an item.
[Save] and [Cancel]	When the operation of a screen is complete, press the [Save] or [Cancel] button to save or cancel the operation, and close the screen.

To reposition a dialogue box:

1. Roll the trackball to move the cursor onto the title bar of the dialogue box. At this time the cursor becomes a \updownarrow ; press <Set>.
2. Roll the trackball and reposition the rectangular graphic to the new desired location.
3. Press the <Set>, and the dialogue box is moved to the desired position.

3.7.3 Touchscreen

- Adjust through the touch screen

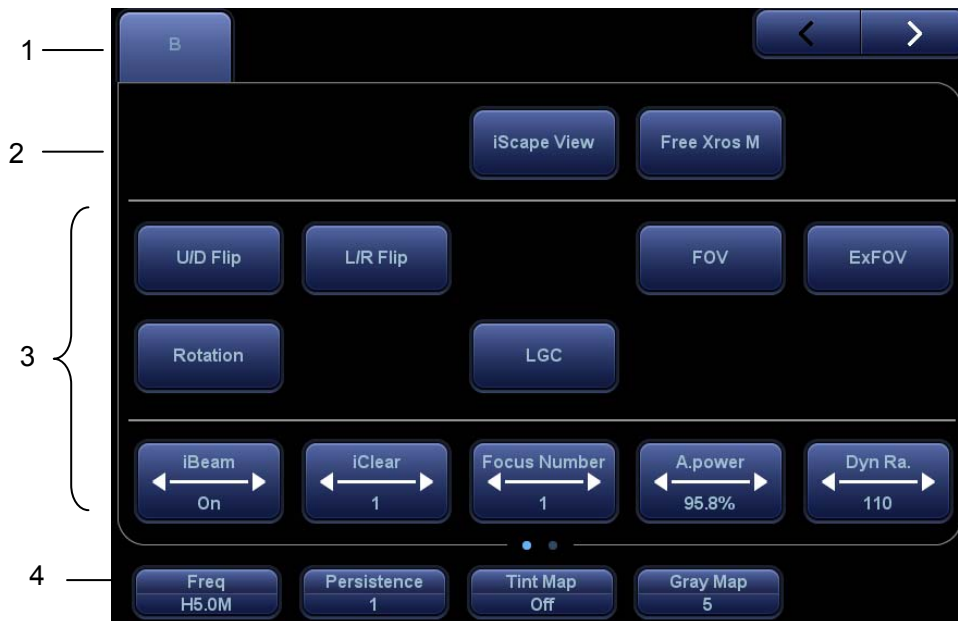

- Mode displaying area (or main functional tabs): displays the current modes, touch the tab to enter the mode.
- Other application mode entrance: displays the available application modes related; tap to enter the modes.
- Parameter adjusting area: displays the parameters in the current imaging mode or function.
 - Parameter magnitude setting: tap ► or ◀ to increase/ decrease the value.
 - ON/OFF setting: some of the parameters only can be set at ON or OFF, ON is to activate the function, and when the function is activated, the key is highlighted in green.
 - Page selection: if there is more than 1 page for the current mode, tap  to turn the pages.
 - Functional item: tap to go to the corresponding function.
- Knob-adjusting area: displays the knob-controlled parameters. There are five knobs at the bottom of the touch screen; their functions vary with the current menu. Press or rotate the knobs to adjust the corresponding parameters.

- Control Panel**

Adjust through trackball, control panel key, deflector rod, knob or slider.

- Trackball function keys**

In some certain mode, you need to use both the trackball and the trackball function keys to adjust.

For instance, in Color mode, use the trackball and the trackball function keys to adjust ROI size/position.

3.7.4 Soft keyboard

Under report, setup, comment adding and iStation screen, the soft keyboard icon  is displayed on the touch screen. Tap the icon to enter the soft keyboard typing screen. Or, under patient info screen, you can see the soft keyboard typing screen on the touch screen directly.



4 Exam Preparation

 **CAUTION:** Before examining a new patient, press <End Exam> to end the exam of the previous patient, update the patient ID and information, to avoid mixing data of the next new patient.

4.1 To Start an Exam

You can start a patient exam in the following situations:

- New patient information: enter the patient information, if it is a new patient, refer to "4.2.1 New Patient Information" for details.
- New exam: to start a new exam for an already registered patient, the recorded information can be obtained either through iStation or Worklist, refer to "4.2.2.1 iStation" and "4.2.2.2 DICOM Worklist" for details.
- Activate an exam: select an exam that is ended within 24 hours, and continue the exam. For details, please refer to "4.5.1 Activate an Exam".

General procedure for an exam: Enter the patient information→Select an exam mode and probe→Choose an imaging mode→Start the exam.

To start a new patient exam, it is better to enter the detailed patient information. The system will set up a unique information database for each patient based on the patient information entered, so that the information of one patient will not be confused with that of another patient.

4.2 Patient Information

- To enter the "Patient Info" screen
 - Press <Patient>, or,
 - Move the cursor onto the patient information area on the monitor and press <Set> to open the screen.
- To exit the "Patient Info" screen
 - Click [OK] on the "Patient Info" screen; or, press <Patient> on the control panel again, to save the settings and exit the screen.
 - Click [Cancel] or press <Esc> to exit the screen without saving any of the entered patient data.
 - Press or <Freeze> to return to the current exam mode with the entered information being saved.
- Click [Quick Register] on the screen to save the patient information quickly and return to the main screen.

4.2.1 New Patient Information

The "Patient Info" screen is shown as follows (Take OB exam for example):

Place the cursor onto the targeted box. The field box is highlighted and a flashing cursor appears. Information can be entered or selected from the options.

You can also change the cursor position by <Tab>, <Enter> or direction keys.

Detailed information is described as follows:

1. General information

- Patient ID
Patient ID is generated automatically by the system after starting a new patient, and can be modified manually. Once you enter the ID and confirm it, you are not allowed to change it. “\” is not permitted.
The ID can be obtained by the bar code reader as well.
For details, please refer to “Appendix A Barcode Reader”
- Name
Enter the patient name directly through the keyboard. Characters of A through Z and 0 through 9 and “.” are allowed.
“\”, “^”, “=” and “,” are not permitted.
- Gender
Select Male, Female or Unknown for patient gender in the drop down list.
- DOB (Date of birth):
You can either enter the birth date of a patient manually according to the format displayed in the field, or click  to select the date. In the table, you can select the desired year (or enter it manually); month and day, then click [OK] to finish it.



- Age:
 - Auto generated age: once the DOB is entered, the system can display an auto-generated age in the field box; the unit can be “Years”, “Months” or “Days”. If the age is less than one year, the system will automatically calculate the age in months or days.
 - Also, you can manually enter the age.

NOTE: When you enter the date manually, please enter it in the format as that of the system.

2. Exam Type

- Exam application type
You can select among 9 types: ABD (Abdomen), OB (Obstetrics), GYN (Gynecology), CARD (Cardiac), VAS (Vascular), URO (Urology), SMP (Small Part), PED (Pediatrics), and Breast.

Select the exam type tab to enter the exam-specific information.

- General information:

Study description: To enter description for each exam.

Primary indications: To enter the primary indications (reason to perform the exam.)

Secondary indications: To enter the secondary indications.

CPT4 code: To enter the CPT4 code.

CPT4 description: To enter the CPT4 description.

Comment Exam specific explanation or remarks.

- Exam specified information:

Exam Type	Information	Description
ABD (Abdomen)	Height	/
	Weight	/
	BSA (body surface area)	After the height and weight are entered, the system will automatically calculate the BSA based on the formula which is set via "[Setup] → [System Preset] → [General]".

Exam Type	Information	Description
OB (Obstetric)	Calculation index	<p>According to the entered index (can be selected in the drop-down list); including LMP (last menstrual period), date of conception (DOC), IVF (in vitro fertilization), PRV (previous exam date), BBT (basic body temperature)), the system can automatically calculate GA and EDD (estimated delivery date); or, calculates GA and LMP according to the EDD and entered date.</p> <ul style="list-style-type: none"> ● LMP: After you enter LMP, the system will calculate and display GA and EDD. ● DOC: after you enter the DOC, the system will calculate the GA and EDD. ● IVF: After you enter IVF, the system will calculate GA and EDD. ● PRV: input the date and GA of the last exam, the system will calculate a new GA and EDD. ● BBT: input BBT, the system will calculate the GA and EDD. ● EDD: after you enter EDD, the system will calculate and display GA and LMP.
	Gravida	Times of pregnancy.
	Ectopic	Times of abnormal pregnancy. e.g. extrauterine pregnancy.
	Gestations	Number of embryos (1, 2, 3;4, 1 is default).
	Para	Times of delivery.
	Aborta	Times of abortion.
GYN (Gynecology)	LMP	Last menstrual period.
	Gravida	Times of pregnancy.
	Para	Times of delivery.
	Ectopic	Times of abnormal pregnancy. e.g. extrauterine pregnancy.
	Aborta	Times of abortion.
	IVF Info	Female hormone basic level and drugs inducing the ovulation.
Cardiology	Height	/
	Weight	/
	BSA (body surface area)	After the height and weight are inputted, the system will automatically calculate the BSA based on the formula which is set via "[Setup] → [System Preset] → [General]".
	BP	Blood pressure.
	HR	/
	RA Press	Right Atrium Pressure.
VAS (Vascular)	Height	/
	Weight	/

Exam Type	Information	Description
	BP(L)	Input left blood pressure.
	BP(R)	Input right blood pressure.
URO (Urology)	Serum PSA	/
	PPSA coefficient	/
SMP (Small Parts)	None	/
PED (Pediatrics)	None	/
Breast	Height	/
	Weight	/

3. Operating Information

- Accession #: exam number used in DICOM. It should be entered within 16 letters or characters; “\” is not permitted.
- Diagnostician: people who is responsible for the exam. “\”, “^”, “=” and “,” are not permitted.
- Operator: people who is responsible for images acquisition and scanning. “\”, “^”, “=” and “,” are not permitted.
- Ref. Physician: the people who requires the ultrasound exam. “\”, “^”, “=” and “,” are not permitted.

4. Functional key

- [Pause Exam]: to pause the current exam.
- [Cancel Exam]: to cancel the current exam.
- [New Patient]: click to clear the current patient information in the patient information screen in order to input information of a new patient.
- [New Exam]: click to clear the entered exam information to start a new exam for the current patient.
- [OK]: click to save the patient data entered and exit the screen.
- [Cancel]: click to cancel the patient data entered and exit the screen.

4.2.2 Retrieve Patient Information

4.2.2.1 iStation

The patient data can be obtained in iStation from the system hardware or USB memory device. You can enter the searching conditions for the patient.



1. To enter iStation screen (the screen is shown as follows):





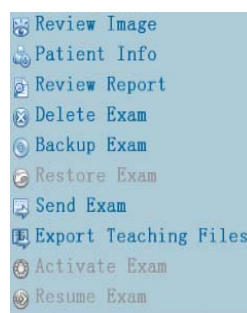

- Press <iStation> on the control panel; or,
- Click [iStation] in the "Patient Info" screen; or,
- Press the <Review> key on the control panel and click [iStation] in the screen.



2. Select the data source:
Select the data source in the drop-down list of "Data Source". The occupying space percentage of the selected data source will be displayed.
3. Set the searching condition
Define the searching item: Name, ID, BOD or Exam Date; and then enter the related keyword.
 - Select "Find in results", the system will search the keyword based on the existed searched results.
4. Select the desired patient information in the list, and the system pops up the following menu:



Button	Function	Description
	Review an Image	Click to enter the Review screen.
	Patient Information	Click to enter the Patient Info screen.
	Review Report	Click to enter diagnostic report screen.

Button	Function	Description
	Delete Exam	Click to delete the selected record.
	Backup Exam	Click to back up the selected patient record to media supported.
	Restore Exam	Click to import the patient data from an external media.
	Send Exam	Click to send the selected patient data to external device, DICOM storage server or printer.
	Export Teaching Files	Click to send the selected record to external devices as teaching file.
	Activate exam	Click to continue an exam that has been finished within 24 hours.
	Continue Exam	Click to continue an exam that has been paused within 24 hours.

Other buttons:

- [New Exam]: click to enter Patient Info screen, meanwhile, the corresponding patient information is also imported to the new exam. After you edit the patient information in the Patient Info screen, select [OK] to start a new exam.
- [Select All Exams]: click to select all records.
- [Exit]: click to exit iStation.

4.2.2.2 DICOM Worklist

When the DICOM basic package is configured and the Worklist server has been set, click [Worklist] in the "Patient Info" screen to query or import the patient data. (For details about Worklist server setting, please refer to the DICOM chapter.)

Procedure:

1. Select data source: choose a worklist server in the drop-down list of "Worklist Server", and then all the patient exam records in the server are listed out.
2. Set the searching condition:
 - Enter the period which includes the exam date, and click [Query] to search.
 - Enter patient ID, patient name, accession #, the system provides the result in real-time.
 - Or select the keyword type, enter the keywords and then click [Query] to search.
 - To reset the criteria, click [Clear] button.
3. Select the desired patient from the list, and:
 - Click [Start Exam], the patient information is imported into the system and then an exam is started.
 - Click [Transfer], the patient information is imported into the "Patient Info" screen. After you edit the patient information in the "Patient Info" screen, click [OK] to start a new exam.
 - Click [Show Detail] to see details of patient data.
4. Click [Exit] to exit the Worklist.

4.3 Select Exam Mode and Probe

CAUTION: If the exam mode is changed during a measurement, all measurement calipers on the image will be cleared. The general measurement data will be lost, but application measurement data will be stored in the reports.

■ Selecting exam mode

1. Connect suitable probes to the system and press <Probe> on the control panel. The touch screen displays the following dialog box:



2. Tap the screen to select the probe type and exam mode. The system exits the dialog box and enters the selected exam mode and probe.
Click [Exit] or press <Probe> again to cancel the selection and exit the screen.

4.3.1 Dual-probe Switch

A user-defined key for dual-probe switch can be defined in preset, by which you can fast switch the probe under B/ Color/ Power mode.

This function applies only to probes with the same exam modes.

1. Scan to obtain the image by current probe.
2. Press the user-defined key. The available probes appear on the screen.
3. Choose the probes to be compared. The system enters dual-probe mode. The image from previous probe is frozen.
4. Scan and obtain the required image from the current probe.
5. Press the user-defined key to switch the images of two probes.

The path for setting the keys: <F10 Setup>→[System Preset]→[Key Config].

1. Select the key to be defined from [Key] tab on the left side. Or, select a key from [Footswitch] tab.

2. Select [Image Mode]→[Dual Probe].
3. Click [OK] to confirm the setting or exit. The setting comes into effect then.

4.4 Select the Imaging Mode

Use the corresponding keys in the control panel to enter the imaging modes.

4.5 Activate& Continue an Exam

4.5.1 Activate an Exam

In iStation screen, select the exam record finished within 24 hours, and click [Activate Exam] from the menu popped up; or, click [Active Exam] in iStation or Review screen to activate the exam.

Tips:

- The system can automatically load the patient information and exam data to continue the exam.
- If you want to continue an exam with data in an external memory database, you have to first allow the system to load the patient data to the system's patient database.

4.5.2 Continue Exam

In iStation screen, select an exam record paused within 24 hours, click [Resume Exam] from the menu popped up to continue the exam.

If you want to select a patient data in an external memory database, you have to first allow the system to load the patient data to the system's patient database.

4.6 Pause & End an Exam

4.6.1 Pause Exam

- Sometimes, you have to stop an uncompleted exam due to some special reasons. When the exam is paused, the system can begin other exams.
 - (1) Press <Patient> to enter Patient Info screen.
 - (2) Click [Pause Exam].
- If the system is powered off during scanning, the exam status turns "paused" after the system restart.

Only one exam can be paused every time.

When an exam is paused, the system will:

 - (1) Save the exam-related images, reports and measurement data, modifies the status as "Paused".
 - (2) Save the exam information, including imaging mode, exam mode, image parameters, operation mode and so on.

4.6.2 End Exam

Before examining a new patient, press <End Exam> to end the exam of the previous patient, update the patient ID and information, to avoid mixing data of the next new patient.

To end an exam, you can do one of the following:

- Press <End Exam> on the control panel.
- Click [New Patient] on the Patient Info screen to end the last patient exam and clear the patient information.
- Click [New Exam] on the Patient Info screen (or iStation screen, or Review screen) to end the last exam and clear the exam data.

5 Image Optimization

⚠ WARNING: The images displayed in this system are for reference only. Mindray is not responsible for the correctness of diagnostic results.

In Dual-B imaging mode, the measurement results of the merged image may be inaccurate. Therefore, the results are provided for reference only, not for confirming diagnoses.

5.1 Imaging Mode

5.1.1 Switching Between Imaging Modes

Switch between imaging modes according to the actual situation.

5.1.2 Image Adjustment

- Adjust using the touch screen.



1. Mode display area (or main functional tabs): displays the current modes. Tap the tab to enter the mode.

2. Other application mode access: displays the available related application modes. Tap to enter the modes.
3. Parameter adjusting area: displays the parameters in the current imaging mode or function.
 - Parameter magnitude setting: tap ◀ or ▶ to increase/decrease the value.
 - ON/OFF setting: some of the parameters can only be set to ON or OFF. ON activates the function, and when the function is activated the key is highlighted in green.
 - Page selection: if there is more than 1 page for the current mode, tap  to turn the pages.
 - Functional item: tap to go to the corresponding function.
4. Knob-adjusting area: displays the knob-controlled parameters.

There are five knobs at the bottom of the touch screen. Their functions vary depending on the current menu. Press or rotate the knobs to adjust the corresponding parameters.

5.1.3 Quickly Saving Image Settings

Press <F7> or user-defined key for QSave to access the image data saving dialog box.

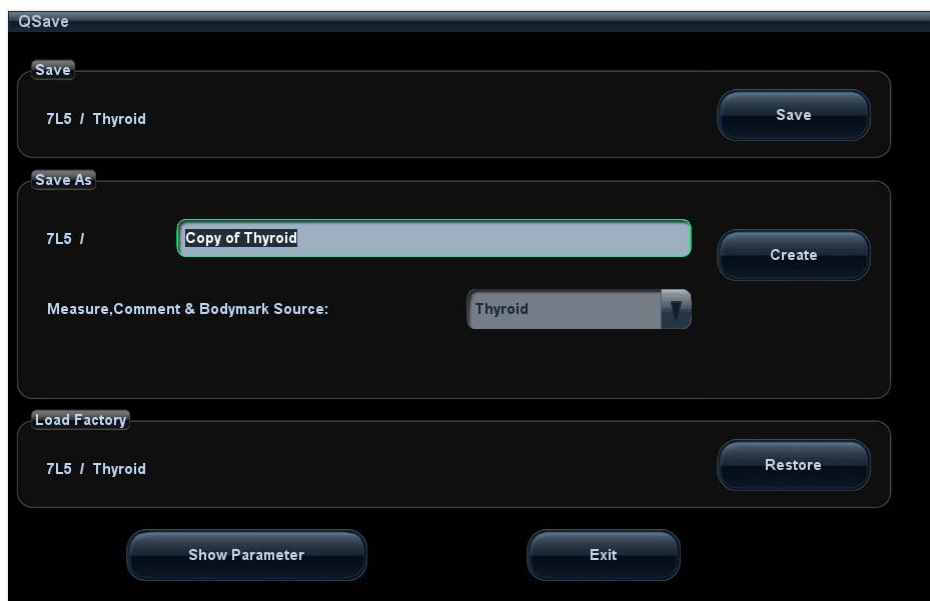

- Save the image parameter adjustment:
Click [Save] to save the current image values for the current exam mode of the particular probe.
- Create new exam data (using the current image parameter settings):
Enter the name in the box after “Save As” to assign a name for a user-defined exam mode, and click [Create] to save the current image parameters, measurements, comments and body mark settings to the exam mode.
- Restore the factory settings:
The settings of the current exam mode and the probe can be restored to factory data by clicking [Restore].

- Check image parameter level and other settings:
 - Click [Show Parameter] to check levels of different image parameters. Click [OK] to save the current image values for the current exam mode of the particular probe.

This function is not available under dual-probe frozen mode.

5.2 B Mode Image Optimization

B mode is the basic imaging mode that displays real-time images of anatomical tissues and organs.

5.2.1 Basic Procedures for B Mode Imaging

1. Enter the patient information. Select an appropriate probe and exam mode.
 2. Press on the control panel to enter B mode.
 3. Adjust the parameters to optimize the image.
 4. Perform other operations (e.g., measurement and calculation) if necessary.
- Press on the control panel to return to B mode at any time.

5.2.2 B Mode Parameters

In B mode scanning, the image parameter area in the top-right corner of the screen displays the real-time parameter values as follows:

Parameter	F	D	G	FR	DR	iClear	iBeam	iTouch	Zoom
Meaning	Frequency	Depth	Gain	Frame Rate	Dynamic Range	Display when the function is turned on.			

5.2.3 B Mode Image Optimization

Frequency

- Description** This function is used to select the operating frequency of the current probe, the real-time value of which is displayed in the image parameter area in the upper left corner of the screen, where “F” represents B mode frequency.
- Operation** You can select a harmonic frequency or a B mode frequency.
Adjust the frequency value through the [Freq] item in the soft menu, “H” indicates harmonic frequency. Values of frequency vary depending upon the probe types.
Select the frequency according to the detection depth and current tissue characteristics.
- Effects** The higher the frequency the better the near field resolution but the worse the force of penetration.
Harmonic imaging enhances near field resolution and reduces low-frequency and large amplitude noise, so as to improve small parts imaging.

Gain

- Description** To adjust the gain of the whole receiving information in B mode. The real-time gain value is displayed in the image parameter area on the top-right corner of the screen.
- Operations** Rotate the knob clockwise to increase the gain, and counter-clockwise to decrease it.
The adjusting range is 0-100 in increments of 1.
- Effects** Increasing the gain will brighten the image and you will see more received signals. However, noise may also be increased.

Depth

- Description** This function is used to adjust the sampling depth, the real-time value of which is displayed in the image parameter area on the top-right corner of the screen.
- Operations** Use the <Depth> deflector rod in the bottom-right part of the control panel to adjust the depth.
The adjustable depth values vary depending on the probe types.
- Effects** Increase the depth to see tissue in deeper locations, or decrease the depth to see tissue in shallower locations.

TGC

- Description** The system compensates the signals from deeper tissue by segments to optimize the image.
There are 8-segment TGC sliders on the control panel corresponding to the areas of the image.
- Operations** To increase the gain compensation in an area of interest, move the TGC slider to the right.
To decrease the gain compensation in the corresponding area of interest, move the TGC slider to the left.
About 1.5 seconds after the adjustment is complete, the TGC curve disappears.
- Effects** Adjust the signal gain for a particular image area to achieve a balanced image.

Acoustic Power

- Description** Refers to the power of ultrasonic waves transmitted by the probe, the real-time value of which is displayed in the upper part of the screen.
- Operations** Adjust the acoustic power through the [A.Power] item on the touch screen. The adjusting range is 3.2-100%.
- Effects** Generally, increasing the acoustic power will increase the brightness and contrast of the image and the force of penetration.
- Impacts** You should perform exams according to actual situations and follow the ALARA Principle.

Focus

- Description** Refers to adjusting the focus of the ultrasonic beams, using the “◀” symbols which are displayed to the right of the image.
- Operations** Adjust the focus number using the [Focus Number] item on the touch screen.
Use the <Focus> deflector rod in the bottom-right part of the control panel to adjust the focus position.
In B mode, the available focus number can be switched between 1-4.
- Effects** The area that is focused will be of a higher contrast and resolution.
- Impacts** The greater the number of focal zones, the slower the frame rate.

Imaging Adjustment

Description	More information can be obtained without moving the probe or changing the sampling position.
FOV (Field of View)	<ol style="list-style-type: none">1. To change the scan range, tap [FOV] on the touch screen to enter the FOV range and FOV position adjustment status.2. Press <Set> to switch between FOV range and FOV position.3. Rotate the trackball to adjust the FOV position or the FOV range. <p>When the scan range is adjusted to its widest, the FOV position cannot be changed.</p> <p>You can get a much larger field of view when selecting a larger FOV.</p> <p>The frame rate decreases when using a larger FOV.</p>
B Steer	Use the <Angle/Steer> key on the control panel to adjust the steer angle.
ExFOV (Extended FOV)	Tap [ExFOV] on the touch screen to turn the function on/off. For linear probes, the ExFOV function displays as trapezoid imaging. For convex probes, the ExFOV function displays as extending the scanning angle.
Impacts	The FOV position/range is available only for convex and phase probes. The ExFOV function is available only for linear and convex probes. The B Steer function is available only for linear probes.

Line Density

Description	The function determines the quality and information of the image.
Operations	Adjust the line density using the [Line Density] item on the touch screen. There are four levels of line density available: UH, M, H, L.
Effects	The higher the line density, the higher the resolution.
Impacts	The higher the line density, the lower the frame rate.

Dynamic Range

Description	This function is used to adjust the B image resolution to compress or expand the gray display range. The real-time value displays in the image parameter area in the top-right corner of the screen.
Operations	Adjust the dynamic range through the [Dyn Ra.] item on the touch screen. Rotate the knob clockwise to increase the value. Rotate the knob counterclockwise to decrease the value. The adjusting range is 30-240dB, in increments of 5dB.
Impacts	The more the dynamic range, the more specific the information and the lower the contrast with more noise.

iClear

- Description** The function is used to enhance the image profile so as to distinguish the image boundary for optimization.
- Operations** Adjust using the [iClear] item on the touch screen.
The system provides 1-4 levels of iClear adjustment: off represents no iClear effect, and the bigger the value the stronger the effect.
- Impacts** It may cause increased noise.

Persistence

- Description** This function is used to superimpose and average adjacent B images, so as to optimize the image and remove noise.
- Operations** Rotate the knob under the [Persistence] item on the touch screen to adjust the value.
The system provides 7 levels of frame average adjustment: the bigger the value the stronger the effect.
- Effects** Persistence can remove image noise to make details clearer.
- Impacts** Increasing Persistence may lead to missing signals.

Rotation/Invert (U/D Flip and L/R Flip)

- Description** The function provides better observation for image display.
- Rotation** Rotate the image using the [Rotation] item on the touch screen.
Images can be rotated by 0°, 90°, 180° and 270°.
When the image is rotated by 90° or 270°, the depth scale is displayed in the top part of the screen.
- Invert (U/D Flip and L/R Flip)** To invert the image horizontally or vertically.
Tap [U/D Flip] or [L/R Flip] on the touch screen to invert the image
- Effects** You can identify the image orientation using the “M” mark on the screen.
By default, the M mark is located in the top-left corner of the imaging area.

iBeam (Spatial Compound Imaging)

- Description** This function is used to superimpose and average images of different steer angles to achieve image optimization.
- Operations** Adjust using the [iBeam] item on the touch screen.
The system provides difefnt levels of iBeam adjustment in single B mode.
Off represents no iBeam.
- Effects** Images can be optimized with less spot noise and higher resolution, so that more details for the structure are revealed.
- Impacts** iBeam is valid for linear and convex probes, and it is not available when the ExFOV function is turned on.

Image Merge

- Description** In the Dual-split mode, when the images of the two windows have the same probe type, depth, invert status, rotation status and magnification factor, the system will merge the two images so as to extend the field of vision.
- Operations** Turn the function on or off using the [Auto Merge] item on the touch screen.
- Impacts** The function is valid only for linear probes.

Gray Map

- Description** This function applies the gray correction to obtain optimum images.
- Operations** Select from among the maps by rotating the knob under the [Gray Map] item on the touch screen. The system provides 25 different gray effect maps.

Tint Map

- Description** This function provides an imaging process based on color difference rather than gray distinction.
- Operations** Rotate the knob under the [Tint Map] item on the touch screen to select the map. The system provides 25 different color effect maps.

TSI (Tissue Specific Imaging)

- Description** The TSI function is used to optimize the image by selecting acoustic speed according to tissue characteristics.
- Operations** Select from among the TSI modes using the [TSI] item on the touch screen.
The system provides four ways of optimizing for specific tissues: general, muscle, fluid and fat.

iTouch (Auto Image Optimization)

- Description** To optimize image parameters as per the current tissue characteristics for a better image effect.
- Operations** Press <iTouch> on the control panel to turn the function on.
The iTouch symbol will be displayed in the image parameter area in the top-right corner of the screen once <iTouch> is pressed.
Select different levels of iTouch effect using [iTouch] on the touch screen.
Long press the <iTouch> key to exit the function.

H Scale

Description Display or hide the width scale (horizontal scale).
The scale of the horizontal scale is the same as that of the vertical scale (depth). They change together in zoom mode, or when the number of the image window changes. When the image is turned up/down, the H Scale will also be inverted.

Operations Tap [H Scale] on the touch screen to display or hide the scale.

LGC

Description Adjust the gain of scan lines to increase the image lateral resolution.

Operation Tap [LGC] on the touch screen to access the adjusting dialog box.
The 8 rods displayed on the touch screen indicate the corresponding image areas on the main screen.
Tap the  to adjust the gain, move downwards to decrease the gain, or move upwards to increase the gain.
The system also provides several preset parameters for imaging.

5.3 M Mode Image Optimization

5.3.1 Basic Procedures for M Mode Imaging

1. Select a high-quality image during B mode scanning, and adjust to position the area of interest in the center of the B mode image.
2. Press <M> on the control panel, and roll the trackball to adjust the sampling line.
3. Press <M> on the control panel again or <Update> to enter M mode. You can then observe the tissue motion along with the anatomical images of B mode. During the scanning process, you can also adjust the sampling line accordingly when necessary.
4. Adjust the image parameters to obtain optimized images.
5. Perform other operations (e.g., measurement and calculation) if necessary.

If “Sampling Line Displaying” is selected, then the screen will display the sampling line all the time and pressing <M> one will lead to entering M mode directly. See “5.1.3 Quickly Saving Image Settings” chapter for details.

5.3.2 M Mode Image Parameters

- In M mode scanning, the image parameter area in the top-right corner of the screen displays the real-time parameter values as follows:

Parameter	F	D	G	V	DR
Meaning	Frequency	Depth	M Gain	M Speed	M Dynamic Range

- During M mode imaging, menus for B mode and M mode are displayed on the touch screen at the same time. You can switch between the 2 modes by clicking the mode tabs.
- During M mode scanning, the frequency, depth, focus position and acoustic power of the probe are synchronous with that of B mode.
- Adjustment of the depth, focus position or TGC to the B mode image will lead to synchronous changes in the M mode image.

5.3.3 M Mode Image Optimization

Gain

- Description** To adjust the gain of M mode image. The real-time gain value is displayed in the image parameter area in the top-right corner of the screen.
- Operations** Rotate the <M> knob clockwise to increase the gain, and counter-clockwise to decrease it.
The adjusting range is 0-100 in increments of 1.
- Effects** Increasing the gain will brighten the image and you will see more received signals. However, noise may also be increased.

Display Format

- Description** To set the display format of M mode images and B mode images.
- Operations** Tap the different display format ratio buttons on the touch screen to adjust. There are 5 formats available for image display: H2:3, V2:3, V3:2, V3:1, Full.
- Effects** Select different format types according to the actual situation and obtain a desired analysis through comparison.

Speed

- Description** This function is used to set the scanning speed of M mode imaging, and the real-time speed value is displayed in the image parameter area in the top-right corner of the screen.
- Operations** Rotate the knob under the [Speed] item on the touch screen to adjust. There are 1-6 levels of scan speed available: the smaller the value the faster the speed.
- Effects** Changing speed makes it easier to identify disorders in cardiac cycles.

Tint Map

- Description** This function provides an imaging process based on color difference rather than gray distinction.
- Operations** Rotate the knob under the [Tint Map] item on the touch screen to select the map. The system provides 1-25 different color effect maps. Off represents the function is disabled.
Press the knob under the [Tint Map] item on the touch screen to turn the function on/off.

Gray Map

Description This function applies the gray correction to obtain optimum images.

Operations To select from among the maps, turn the knob under [Gray Map] item on the touch screen. The system provides 25 different gray effect maps.

Edge Enhance

Description This function is used to enhance the image profile so as to distinguish the image boundary for optimization.

Operations Adjust using the [Edge Enhance] item on the touch screen.
There are 0-3 levels of edge enhance adjustment available: the bigger the value the stronger the effect.

Impacts Larger edge enhance may lead to increased noise.

Dynamic Range

Description This function is used to adjust the M image resolution to compress or expand the gray display range.
The real-time dynamic range value is displayed in the image parameter area in the top-right corner of the screen.

Operations Rotate the knob under the [Dyn Ra.] item on the touch screen.
The adjusting range is 30-240dB, in increments of 5dB.

Effects The more the dynamic range, the more specified the information.

M Soften

Description This feature is used to process the scan lines of M images to reject noise, making image details clearer.

Operations Adjust using the [M Soften] item on the touch screen.
The system provides 0-14 levels of M Soften adjustment: the bigger the value the stronger the effect.

5.4 Color Mode Image Optimization

The Color mode is used to detect color flow information, and the color is designed to judge the direction and speed of blood flow.

Generally, the color above the color bar indicates the flow towards the probe, while the color below the color bar indicates the flow away from the probe. The brighter the color, the faster the flow speed, while the darker the color, the slower the flow speed.

5.4.1 Basic Procedures for Color Mode Imaging

1. Select a high-quality image during B mode scanning, and adjust to position the area of interest in the center of the B mode image.
2. Press <Color> to enter B + Color mode. Roll the trackball to change the position and size of the Region of Interest (ROI) and press the <Set> key to set.
3. Adjust the image parameters during scanning to obtain optimized images.
4. Perform other operations (e.g., measurement and calculation) if necessary.

5.4.2 Color Mode Image Parameters

- In Color mode scanning, the image parameter area in the top-right corner of the screen displays the real-time parameter values as follows:

Parameter	F	G	PRF	WF
Meaning	Frequency	Color Gain	Pulse Repetition Frequency (PRF)	Color Wall Filter

- During Color mode imaging, the image optimizing menus for B mode and Color mode are displayed on the touch screen at the same time. You can switch between the 2 modes by clicking the mode tabs.
- In Color mode, the acoustic power is synchronous with that of B mode. Adjustment of the depth to the B mode image will lead to corresponding changes in Color mode image.

5.4.3 Color Mode Image Optimization

Color Gain

Description Refers to the overall sensitivity to flow signals. This function is used to adjust the gain in Color mode. The real-time gain value is displayed in the image parameter area in the top-right corner of the screen.

Operations Rotate the <Color> knob clockwise to increase the gain, and counter-clockwise to decrease it.

The adjusting range is 0-100 in increments of 2.

Effects Increasing the gain will increase the flow signal presented and noise. The signals may be missing when the gain is adjusted too low.

ROI Adjustment

- Description** This function adjusts the width and position of the ROI in Color mode.
- Operations** When the ROI box is a dotted line, roll the trackball to change the size.
When the ROI box is a solid line, roll the trackball to change the position.
Press <Set> to switch between the solid line and the dotted line.
- Impacts** The larger the ROI box, the lower the frame rate, and the lower the resolution and color sensitivity.

B/C Align

- Description** To set and restrict the maximum width of the B mode image to that of the Color ROI.
- Operations** Turn the function on or off using the [B/C Align] item on the touch screen.
- Impacts** The frame rate increases when the function is turned on.

Dual Live

- Description** This function is used to display the B image and Color image synchronously.
- Operations** Turn the function on or off using the [Dual Live] item on the touch screen.
When the function is turned on, the window will automatically switch to dual windows (one for the B image, and the other for the Color image).

Steer

- Description** The feature is used to adjust the ROI of the color flow of different angles with immobility of the linear probe.
- Operations** Adjust using the <Angle/Steer> key on the control panel.
- Effects** This function is used to adjust the scan angle of linear probes, so as to change the angle between the transmitting beam and flow direction.
- Impacts** Steer is only valid for linear probes.

Line Density

- Description** Line density determines the quality and information of the image.
- Operations** Adjust using the [Line Density] item on the touch screen.
4 levels of line density are provided: H, L, UH, M.
- Effects** The higher the line density, the higher the resolution.
- Impacts** The higher the line density, the lower the frame rate.

Packet Size

- Description** This function is an indication of the ability to detect flow, which is used to adjust the accuracy of color flow.
- Operations** Rotate the knob under the [Packet Size] item on the touch screen to adjust the value.
There are 0-3 levels of packet size available: 0 represents no packet size control and the bigger the value the higher the sensitivity.
- Effects** The higher the packet size, the more sensitive the indication for low-velocity flow.
- Impacts** Adjusting the packet size may lead to the frame rate changing.

Persistence

- Description** This function adjusts the temporal smoothing in Color mode to optimize the image.
- Operations** Adjust through the [Persistence] item on the touch screen.
The system provides 0-4 levels of persistence adjustment: 0 represents no persistence, and the bigger the value the stronger the effect.

Smooth

- Description** This feature is used to reject noise and smooth the image.
- Operations** Adjust using the [Smooth] item on the touch screen.
The system provides 0-4 levels of smooth function: the bigger the value the stronger the effect.

Scale

Description This function is used to adjust the speed range of the color flow, which is adjusted using the PRF in the system. The real-time PRF value is displayed in the image parameter area in the top-right corner of the screen.

Operations Adjust through the [Scale] item on the touch screen.
The adjusting range varies according to the frequency, probe and depth. Adjust according to the actual situation.

Effects Provides a much clearer color flow image.
Use a low PRF to observe low-velocity flows, and a high PRF to observe high-velocity flows.

Impacts Aliasing may occur if a low-velocity scale is used and high velocities are encountered.
Low velocities may not be identified when a high-velocity scale is used.

Baseline

Description Refers to the area where the velocity is zero in the scale. Adjust according to the actual situation so as to get an optimum flow display.

Operations Adjust through the [Baseline] item on the touch screen.
A positive value means increase the signals above the baseline, and a negative value means increase the signals below the baseline.

Invert

Description To set the display mode of the color flow. The color scale will be inverted when the function is turned on.

Operations Turn the function on or off using the [Invert] item on the touch screen.
Select "Auto Invert" in "[Setup] (F10)→[System]→[Image]", so the color bar can automatically invert when the color flow is steered to a certain angle to accommodate the operator's desire to distinguish the flow direction.
Auto invert function is available only for linear probes.

Map

Description This function is a combination of several image parameters, which indicates the display effect of the color image.

Operations Rotate the knob under the [Map] item on the touch screen to select from among the maps.
The system provides 21 different maps for selection. The V group provides 11 ordinary maps and the VV group provides 10 2D maps.

WF (Wall Filter)

Description It filters out low-velocity signals to provide effective information, and this function is used to adjust the filtered frequency. The real-time value is displayed in the image parameter area in the top-right corner of the screen.

Operations Select using the [WF] item on the touch screen.
There are 0-7 levels of wall filter function available. Select the value according to the actual situation.

Impacts Flow signals may be missing.

Priority

Description This function is used to set the levels of the flow display and to display the grayscale signal or color signal.

Operations Rotate the knob under the [Priority] item on the touch screen to select the value.

The adjusting range of the priority is 0-100% in increments of 10%.

The higher the value, color signals are first to be displayed. The lower the value, grayscale signals are first to be displayed.

Velocity tag

Description This function is used to mark the specified velocity range in the flow to check the flow function or specific flow velocity value.

Operation

1. Tap [Velocity Tag] on the touch screen to enter the velocity marking status. A green mark appears on the color bar.
2. Roll the trackball upwards and downwards to select the marking velocity.
3. Press <Set> to enter the tag range selection status, and roll the trackball upwards and downwards to select the range.

Press <Set> to switch between marking position and marking range.

iTouch (Auto Image Optimization)

Description To optimize image parameters as per the current tissue characteristics for a better image effect.

Operations Press <iTouch> on the control panel to turn the function on.

5.5 Power Mode Image Optimization

Power mode provides a non-directional display of the blood flow in terms of intensity as opposed to flow velocity.

DirPower (Directional Power mode) provides additional information of the flow direction toward or away from the probe.

5.5.1 Basic Procedures for Power Mode Imaging

1. Select a high-quality image during B mode or B + Color scanning, and adjust to position the area of interest in the center of the image.
2. Press <Power> to enter B + Power mode. Roll the trackball to change the position of the Region of Interest (ROI) and press the <Set> key to set. Roll the trackball to change the size and position of the ROI.
3. Adjust the image parameters during B + Power mode scanning to obtain optimized images.
4. Perform other operations (e.g., measurement and calculation) if necessary.

5.5.2 Power Mode Image Parameters

- In Power mode scanning, the image parameter area in the top-right corner of the screen displays the real-time parameter values as follows:

Parameter	F	G	PRF	WF
Meaning	Frequency	Power Gain	Pulse Repetition Frequency (PRF)	Power Wall Filter

- During Power mode imaging, the image optimizing menus for B mode and Power mode are displayed on the touch screen at the same time. You can switch between the 2 modes by clicking the mode tabs.
- In Power mode, the acoustic power is synchronous with that of B mode. Adjustment of the depth to the B mode image will lead to corresponding changes in Power mode image.

Parameters consistent with those in Color mode and B mode are not to be introduced. See the relevant Color mode and B mode sections, while special items of the Power mode are introduced in the following.

5.5.3 Power Mode Image Optimization

Power Gain

Description Refers to the overall sensitivity to flow signals. This function is used to adjust the gain in Power mode.

The real-time gain value is displayed in the image parameter area in the top-right corner of the screen.

Operations Rotate the <Color> knob clockwise to increase the gain, and counter-clockwise to decrease it.

The adjusting range is 0-100 in increments of 2.

Effects Increasing the gain will increase the flow signal presented and noise. The signals may be missing when the gain is adjusted too low.

Map

Description This feature indicates the display effect of the Power image.
The maps in the Power mode image are grouped into two categories: Power maps and Directional Power maps.

Operations To select from among the maps, turn the knob under [Map] on the touch screen.

There are 8 kinds of maps provided: P0-3 belong to Power mode maps, while dP0-dP3 belong to Directional Power mode maps.

The Power maps provide information about blood flow, which are highly sensitive to the low-velocity flows.

The Directional Power maps provide information about flow direction.

Dynamic Range

Description This function adjusts the transformation of echo intensity into color signal.

Operations Adjust through the [Dyn Ra.] item on the touch screen to adjust the dynamic range.

The adjusting range is 10-70dB in increments of 5dB.

Effects Increasing the dynamic range leads to higher sensitivity to low-power signals, thus enhancing the range of signals to display.

5.6 PW/CW Doppler Mode

PW (Pulsed Wave Doppler) mode or CW (Continuous Wave Doppler) mode is used to provide blood flow velocity and direction utilizing a real-time spectrum display. The horizontal axis represents time, while the vertical axis represents Doppler frequency shift.

PW mode provides a function for examining flow at one specific site for its velocity, direction and features. CW mode proves to be much more sensitive to high-velocity flow display. Thus, a combination of both modes will contribute to a much more accurate analysis.

Adjustment items, such as SV, Steer, Duplex, Triplex, iTouch and HPRF, are not available in CW mode.

5.6.1 Basic Procedures for PW/CW Mode Exam

1. Select a high-quality image during B mode or B + Color (Power) mode scanning, and adjust to position the area of interest in the center of the image.
2. Press <PW>/<CW> to adjust the sampling line,
 - The sampling status will be displayed in the image parameter area in the top-right corner of the screen as follows:



PW Sampling Line Adjustment	SV
	Angle
	SVD
CW Sampling Line Adjustment	Angle
	CW Focus Depth

3. Set the position of the sample line by moving the trackball left and right. Set the SVD by moving the trackball up and down. Adjust the angle and SV size according to the actual situation.
4. Press <PW>/<CW> or <Update> again to enter PW/CW mode and perform the examination. You can also adjust the SV size, angle and depth in real-time scanning.
5. Adjust the image parameters during PW/CW mode scanning to obtain optimized images.
6. Perform other operations (e.g., measurement and calculation) if necessary.

If “sampling line displaying” is selected, then the screen will display the sampling line all the time and pressing <M> one will lead to entering M mode directly. For details, see “5.1.3 Quickly Saving Image Settings” chapter.

5.6.2 PW/CW Mode Image Parameters

In PW/CW mode scanning, the image parameter area in the top-right corner of the screen displays the real-time parameter values as follows:

PW	Parameter	F	G	PRF	WF	SVD	SV	Angle
	Meaning	Frequency	Gain	PRF	Wall Filter	SV Position	SV Size	Angle
CW	Parameter	F	G	PRF	WF	SVD		Angle
	Meaning	Frequency	Gain	PRF	Wall Filter	SV Position		Angle

- During PW/CW mode imaging, the image optimizing menus for B mode and PW/CW mode are displayed on the touch screen at the same time. If Color mode (Power mode) is also working, menus for certain modes will be displayed on the touch screen synchronously, and you can switch between them by clicking the mode tabs.
- When you adjust the depth of the B mode image, related changes will occur in the PW/CW mode image as well.
- Most of the parameters are the same for the PW mode and CW modes, so parameters of both are combined together to be introduced here.

Only phased probes support CW mode.

5.6.3 PW/CW Mode Image Optimization

Gain

- Description** This function is intended to adjust the gain of the spectrum map. The real-time gain value is displayed in the image parameter area in the top-right corner of the screen.
- Operations** Rotate the [PW] knob clockwise to increase the gain, and counter-clockwise to decrease it.
The adjusting range is 0-100 in increments of 2.
- Effects** Increasing the gain will brighten the image and you will see more received signals. However, noise may also be increased.

SV

- Description** To adjust the SV position and size of sampling in PW mode, the real-time value of SV and SVD are displayed in the image parameter area in the top-right corner of the screen.
- SV size** Rotate the knob under [SV] on the touch screen to adjust the SV size.
Value: 0.5-20 mm.
- SVD** Roll the trackball to select the SV depth.
- Effects** The smaller the SV size, the more accurate the result. More details are obtained when selecting a large SV size.

CW Focus Position

- Description** To adjust the CW mode SVD. The real-time focus position value is displayed in the image parameter area in the top-left side of the screen.
- Operation** Roll the trackball to select the focus depth.

Scale

- Description** This function is used to adjust the speed range of the flow, which is adjusted using the PRF in the system.
The real-time PRF value is displayed in the image parameter area in the top-right corner of the screen.
- Operations** Rotate the knob under the [Scale] item on the touch screen.
- Effects** Provides a much clearer color flow image.
Use a low PRF to observe low-velocity flows, and a high PRF to observe high-velocity flows.
- Impacts** Aliasing may occur if a low-velocity scale is used and high velocities are encountered.
Low velocities may not be identified when a high-velocity scale is used.

iTouch

- Description** To optimize image parameters as per the current tissue characteristics for a better image effect.
- Operations** Press <iTouch> on the control panel to turn the function on.

Auto-Calculation

- Description** This function is used to trace the spectrum and calculate the PW/CW mode image parameters. The results are displayed in the results window.
Tap [Auto Calc] on the touch screen to turn the auto calculation function on or off.
- Auto Calculation Parameter** Select parameters in the dialog box prompted by touching [Auto Calc Param] on the Auto Calculation page.
- Auto Calculation Cycle** To set the heart cycle number for auto-calculation.
Tap [Auto Calc Cycle] on the touch screen to select the cycle number, the adjusting range is 1-5.
- Trace Area** To set the trace area of the Doppler wave in the spectrum map, applicable for auto calculation, V Max and V Mean display.
To change the trace area, adjust through [Trace Area] item on the touch screen.
The available selections of trace area are: Above, Below, All.

Invert

- Description** This function is used to set how the spectrum is displayed.
- Operations** Turn the function on or off using the [Invert] item on the touch screen.
Select "Auto Invert" in the "[Setup] (F10) → [System] → [Image]", so the spectrum can automatically invert when the color flow is steered to a certain angle to accommodate the operator's desire to distinguish the flow direction.

Speed

- Description** This function is used to set the scanning speed of PW mode imaging.
- Operations** Rotate the knob under the [Speed] item on the touch screen.
There are 6 levels of scan speed available: the smaller the value the faster the speed.
- Effects** Changing the speed makes it easier to identify the cardiac cycles and to detect more details.

T/F Res.

- Description** This function is used to create a balance between time resolution and spatial resolution.
- Operations** Adjust using the [T/F Res.] item on the touch screen.
There are 0-4 levels of T/F Res. values available.

Wall Filter

- Description** It filters out low-velocity signals to provide effective information, and this function is used to adjust the filtered frequency. The real-time value is displayed in the image parameter area in the top-right corner of the screen.
- Operations** Select using the [WF] item on the touch screen.
0-6 levels of wall filter function are provided.
- Impacts** Signals of low-velocity flow may be missing.

Tint Map

- Description** This function provides an imaging process based on color difference rather than gray distinction.
- Operations** Adjust through the [Tint Map] item on the touch screen to select the map. There are 1-25 color effect maps available. Off represents the function is disabled.

Gray Map

- Description** This function applies the gray correction to obtain optimum images.
- Operations** To select from among the maps, turn the knob under [Gray Map] on the touch screen. There are 1-25 gray effect maps available.

Display Format

- Description** To set the display format of PW mode images with B mode images.
- Operations** Tap the different display format ratio buttons on the touch screen to adjust. There are 5 formats for displaying the images: H2:3, V2:3, V3:2, V3:1, Full.

Duplex/Triplex

- Description** This function is used to set whether a B image (B + Color image) and PW image are displayed synchronously.
- Operations** Tap [Duplex]/[Triplex] on the touch screen to turn the synchronization on or off.

HPRF

- Description** HPRF mode is used when detected velocities exceed the processing capabilities of the currently selected PW Doppler scale, or when the selected anatomical site is too deep for the selected PW Doppler scale.
- Operations** Turn the function on or off using the [HPRF] item on the touch screen.
- Effects** HPRF enhances the range for detecting high-velocity flow.

Baseline

- Description** Refers to the area where the velocity is zero in the spectrum.
- Operations** Rotate the knob under [Baseline] to adjust.
- Effects** Changes the flow-velocity range to optimize the image.

Angle

- Description** This function is used to adjust the angle between Doppler vector and flow to make the velocity more accurate. The real-time adjusting angle value is displayed on the right part of the spectrum map.
- Operations** Use the <Angle/Steer> key on the control panel to adjust it. The adjustable angle range is -89~89°, in increments of 1°.

Quick Angle

- Description** To adjust the angle faster, in increments of 60°. The real-time value is displayed on the right part of the spectrum map.
- Operations** Adjust using the [Quick Angle] item on the touch screen. There are 3 angles for quick adjustment: -60°, 0° and 60°.

Dynamic Range

- Description** The dynamic range conveys the information which is being transformed from echo intensity to grayscale.
- Operations** Adjust using the [Dyn. Ra.] item on the touch screen.
The adjusting range is 24-72dB.
- Effects** The more the dynamic range, the more specific the information and the lower the contrast with more noise.

Audio

- Description** This function is used to adjust the output audio in the spectrum map.
- Operations** Rotate the <Volume> knob on the left of the touch panel to adjust the volume.
Press the <Volume> knob to open or shut down the volume.
The adjusting range of the audio is 0-100%.
- Effects** Utilizing the output audio helps to identify the feature and the status of flow.

Steer

- Description** This function is used to adjust the angles for the sampling line.
- Operations** Use the <Angle/Steer> key on the control panel to switch to "Steer adjustment". Tap [Steer] on the touch screen to adjust. The adjusting range is -12 to 12.
- Effects** This feature is used to steer the direction of the beam so as to change the angle between the beam and flow direction with immobility of the linear probe.
The values of steer angles vary according to the probe.
- Impacts** The PW Steer function is available only for linear probes.

5.7 Color M Mode

Color M mode provides information about color flow or tissue on the M mode images to indicate the cardiac motion state. It is highly sensitive to the flow or tissue movement.

The Color M mode includes Color Flow M mode and Color Tissue M mode.

CM mode is not available for linear probes.

5.7.1 Enter Color M Mode

- Color Flow M Mode
 - In B + M mode, press <Color> on the control panel to enter the sampling line adjustment status, and press <M> again.
 - In B + Color, B + Color + PW or B + Color + CW mode, press <M> twice on the control panel.
- Color Tissue M Mode (TVM)
 - In B + TVI/TVD, or B + TVI + TVD mode, press <M> twice on the control panel.
 - In Color Flow M mode, press user-defined key for TDI on the control panel (Assign a key as user-defined TDI: the setting path is "[Setup]→[System]→[Key Config]", see "12.1.6 Key Configuration" chapter for details) or tap [TDI] on the touch screen to enter the sampling line adjustment status, and press <M> again.

5.7.2 Exit Color M Mode

- Press <Color> or <M> on the control panel to exit Color M mode.
- Or, press on the control panel to return to B mode.

5.7.3 Color M Mode Image Parameters

- In Color Flow M mode, the parameters that can be adjusted are the same as those in B, M and Color modes. See the relevant B, Color and M mode sections for details.
- In Color Tissue M mode, the parameters that can be adjusted are the same as those in B, M and TVI modes. See the relevant B, M and TVI mode sections for details.
- In Color M mode scanning, the image parameter area in the top-right corner of the screen displays the real-time parameter values.
- ROI Adjustment

The ROI determines the size and position of the color flow or color tissue displayed in the Color M mode image.

 - Set the position of the sampling line by moving the trackball left and right, and set the ROI position by moving the trackball up and down.
 - Set the ROI size by moving the trackball.
 - Press <Set> to switch the cursor status between ROI position adjustment and ROI size adjustment.
- Press <Update> on the control panel to switch between the real-time mode and freeze mode.

5.8 Anatomical M Mode

 **CAUTION:** Anatomical M Mode and Color Anatomical M mode images are provided for reference only, not for confirming diagnoses. Compare the image with those of other machines, or make diagnoses using non-ultrasound methods.

For an image in the traditional M mode, the M-mark line goes along the beams transmitted from the probe. Thus it is difficult to obtain a good plane for difficult-to-image patients who cannot be moved easily. However, in the Anatomical M mode, you can manipulate the M-mark line and move it to any position at desired angles. The system supports anatomical M scanning (including Free Xros M mode and Free Xros CM mode) in 2D imaging modes (B, Color, Power and TVI mode).

- **Shortcut key setting**

You can preset a user-defined key for entering Free Xros M mode: [Setup] (F10)→ [System]→ [Key Config.]. See “12.1.6 Key Configuration” for details.

Free Xros M imaging and Free Xros CM imaging are options.

5.8.1 Free Xros M Imaging (Anatomical M-Mode)

5.8.1.1 Basic Procedures for Free Xros M Imaging

1. In real-time 2D mode or M mode, adjust the probe and image to obtain the desired plane.
Or select the desired 2D cine files.
 2. Tap [Free Xros M] on the touch screen of the B mode tab to enter Free Xros M mode, or press the user-defined key.
 3. Adjust the M-mark (single or multiple) line to obtain optimized images and necessary information.
- In Dual-split or Quad-split mode, it is the currently activated window that enters the Free Xros M mode.

Free Xros M imaging is supported on frozen B images, B+M images and B+Power/Color/TVI images.

5.8.1.2 Free Xros M Image Parameters

- During Free Xros M mode imaging, the image optimizing menus for B mode and Free Xros M mode are displayed on the touch screen at the same time. You can switch between the 2 modes by tapping the mode tabs.
- Parameters consistent with those in M mode are not to be introduced. See the relevant M mode section, while Free Xros M mode special items will be introduced in the following.

Display/Hide the M-mark Line

Description	There are 3 M-mark lines available, each with “A”, “B” or “C” at the one end as identification and an arrow at the other end to mark the direction.
M-mark Line Selection	Perform the selection using the [Show A], [Show B] or [Show C] item on the touch screen, and the corresponding image will be displayed on the screen once the related item is selected.
Display current	Tap [Display Cur.] or [Display All] on the touch screen to select whether to display the image of the current M-mark line or all.
Impacts	When there is only one M-mark line on the screen, it cannot be hidden.

Switching between the M-mark Lines

Description	To switch between the M-mark lines in Free Xros M mode.
Operations	Press <Set> to switch between the M-mark lines and press <Cursor> to show the cursor. The activated M-mark line will be green and the inactivated one will be white.

Adjusting the M-mark Line

Description	To adjust the position and angle of the M-mark line.
Operations	<ul style="list-style-type: none">● Position Adjustment When the M-mark line is activated, move the trackball left and right to adjust the position. The direction is recognized by the arrow at the end of the line.● Angle Adjustment When the M-mark line is activated, move the trackball to adjust the fulcrum of the line, and adjust using the [Angle/Steer] key on the control panel. The adjusting angle range is 0-360°, in increments of 1°.

5.8.1.3 Exit Free Xros M

In Free Xros M mode, tap [Free Xros M] or press B or the user-defined Free Xros M key to exit Free Xros M mode.

5.8.2 Free Xros CM (Curved Anatomical M-Mode)



CAUTION: Free Xros CM images are provided for reference only, not for confirming diagnoses. Compare the image with those of other machines, or make diagnoses using non-ultrasound methods.

In Free Xros CM mode, the distance/time curve is generated from the sample line manually depicted anywhere on the image. Free Xros CM mode can be entered using TVI and TEI modes.

Only the phased probe supports Free Xros CM.

5.8.2.1 Basic Procedures for Free Xros CM

1. In 2D real-time imaging mode, adjust the probe and image to get the desired image, then fix the probe.
2. Press [TDI] user-defined key to enter TDI imaging and acquire the necessary images.
3. Press the user-defined key for Free Xros CM or tap [Free Xros CM] on the touch screen to enter Free Xros CM mode.
4. Roll the trackball to define the start point of the sample line on the 2D image. The cursor displays as , and can only be moved within the 2D image.
5. Press <Set> to fix the start point. The digital number “1” is marked beside the point.
6. Define the next point using the trackball and <Set> key (tap [Undo] to cancel the current point and activate the preview point). The system updates the time-motion curve in real time. The sample line is displayed in green, and each point is marked with a number in sequence.
7. Repeat Step 6 to finish the sample line.
8. Double-click the <Set> key to end editing. The sample line is displayed in white.
9. Adjust the image parameters to optimize the image, obtain the relevant tissue image for data analysis, then save the image if necessary.
10. Press the user-defined key again or to exit Free Xros CM mode.

Sample Line Modification

1. To enter curve (sample line) modification status:
For a completed sample line, set [Edit] to “On” and the sample line is editable.
2. Anchor the cursor to a certain point, press the <Set> key to activate the point, then roll the trackball to drag the point for a desired sample line.
3. Double-click the <Set> key to end editing. The sample line is displayed in white.

Delete a Sample Line

Tap [Delete] to delete the selected line. You can re-create a new sample line.

Tip:

The free Xros M mode and Free Xros CM mode parameters are independent of each other, but their functions are the same. Free Xros CM parameters are not to be introduced. See the relevant M mode and Free Xros M mode sections.

5.9 TDI

TDI mode is intended to provide information about low-velocity and high-amplitude tissue motion, specifically for cardiac movement.

4 types of TDI mode are available:

- Tissue Velocity Imaging (TVI): this imaging mode is used to detect tissue movement with direction and speed information. In general, the warm color indicates movement toward the probe, while the cool color indicates movement away from the probe.
- Tissue Energy Imaging (TEI): this imaging mode reflects the status of cardiac movement by displaying the intensity of tissue. The brighter the color the less the intensity.

- Tissue Velocity Doppler Imaging (TVD): this imaging mode provides quantifiable direction and velocity information about the tissue.
- Tissue Velocity M Imaging (TVM): this function assists in observing the cardiac motion through a direct angle. TVM mode is also called Color Tissue M mode which has been introduced in the Color M mode chapter. See “5.7 Color M Mode” for details.

TDI imaging and TDI QA are options.

Only the phased probe in cardiac exam mode supports the TDI function.

5.9.1 Basic Procedures for TDI Imaging

- Press user-defined key for TDI on the control panel in real-time scanning to enter the modes (Assign a key as user-defined TDI: the setting path is "[Setup]→[System]→[Key Config]", see “12.1.6 Key Configuration” chapter for details), or tap [TDI] on the touch screen directly:
 - In B or B+Color mode: to enter TVI Mode, TVI mode parameters will be displayed on the touch screen.
 - In Power mode: to enter TEI Mode, TEI mode parameters will be displayed on the touch screen.
 - In PW mode: after pressing the [TDI] user-defined key, press <PW> or <Update> to enter TVD Mode, TVD mode parameters will be displayed on the touch screen.
 - In M mode: after pressing the [TDI] user-defined key, press <M> or <Update> to enter TVM Mode, TVM mode parameters will be displayed on the touch screen.
- Switching between the TDI sub-modes
In TDI mode, press <Color>, <Power>, <M> or <PW> to switch between the modes.
- Exit TDI
 - Press [TDI] user-defined key to exit TDI mode and enter general imaging modes.
 - Or, press on the control panel to return to B mode.

5.9.2 TDI Image Parameters

- In TDI mode scanning, the image parameter area in the top-right corner of the screen displays the real-time parameter values as follows:

- TVI/TEI

Parameter	F	G	PRF	WF
Meaning	Frequency	Gain	PRF	Wall Filter

- TVD

Parameter	F	G	PRF	WF	SVD	SV	Angle
Meaning	Frequency	Gain	PRF	Wall Filter	SV Position	SV Size	Angle value

5.9.3 TDI Image Optimization

In each TDI mode, the parameters that can be adjusted are similar to those in the color flow modes (Color, PW, and Power). See the relevant sections for details. The following introduces the specific items in TDI mode.

5.9.4 TDI Quantitative Analysis (QA)



CAUTION:

TDI Quantitative Analysis results are provided for reference only, not for confirming diagnoses. Compare the results with those of other machines, or make diagnoses using non-ultrasound methods.

TDI QA is applied for TVI original data analysis, for evaluating the velocity change of the same cardiac muscle with cardiac cycles.

TDI QA Workflow:

1. Perform image scanning on cardiac muscle, freeze the image and select a range of images for analysis, or select a desired cine loop from the stored images.
Tip:
 - Images from the current scan session (already in freeze mode) or from a saved image loop can be used for TDI QA.
 - TDI QA is only available if the user has selected an image loop. If the user has selected a saved still image (just one frame), the TDI QA function is not available.
2. Tap [TDI-QA] on the TVI touch screen page to activate the TDI QA function, or press the user-defined key for TDI QA directly.
3. Mark out the part of interest.
4. Save the curved image, export the data and perform parameter analysis.
5. Tap [Exit] to exit the TDI QA function.

5.9.4.1 TDI QA Screen Description

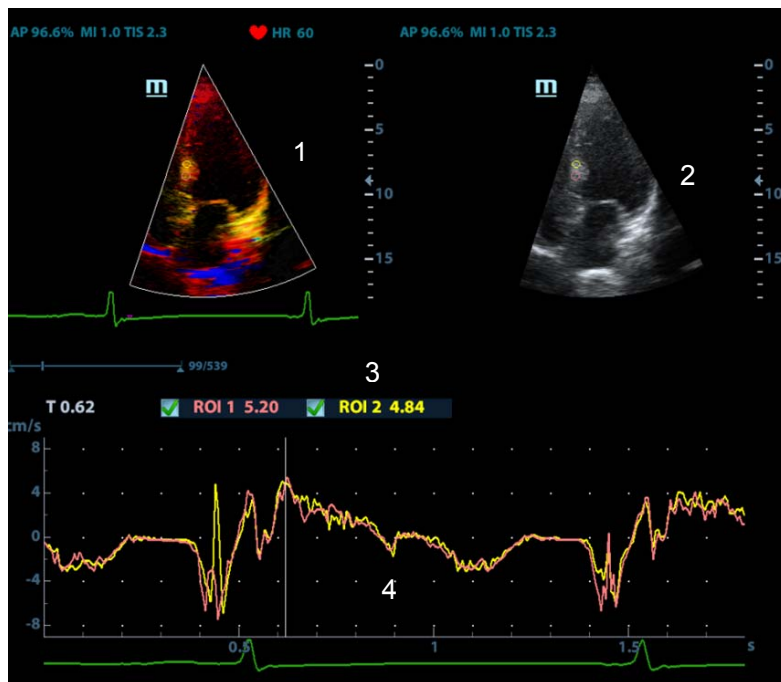

TDI QA Screen

1 - TVI Cineloop window

Sample area: indicates the sampling position of the analysis curve. The sample area is color-coded, 8 (maximum) sample areas can be indicated.

2 - B Cineloop window

Tip:

- The images in the TVI cineloop window and B cineloop window are the frozen image of the same moment. Roll the trackball to review the images in the two cineloop windows.
- Sample areas are linked in the TVI cineloop window and B cineloop window.

3 - Displays the analysis curve

- The Y-axis represents the speed (unit: cm/s). [In the Strain Rate – Time curve, the Y-axis represents the strain (%). In the Strain – Time curve, the Y-axis represents the strain rate (1/s).]
- The X-axis represents the time (unit: s).
- Frame marker: a white line perpendicular to the X-axis which can be moved horizontally left to right (and right to left) by rolling the trackball.
- Click the checkbox beside the ROI to set whether to hide or display the QA curve.
- You can get the current X/Y-axis value by moving the cursor onto one point on the curve. If you press <Set> now, the frame marker will move to that spot.

4 - Displays the ECG trace (no ECG trace displayed here).

5.9.4.2 Basic TDI QA Procedures

Setting the ROI

This function is used for setting the TDI QA target.

Up to eight ROIs can be saved on the reference image, with the corresponding eight traces plotted simultaneously on the graph. Each ROI display has a different color, and its corresponding trace data is plotted with the same color.

There are two different methods for determining the shapes of the sample area: Standard ROI and Freehand ROI.

ROI types:

- Standard ROI: if selected, the ROI is drawn automatically with its shape determined by "Standard Height/Width/Angle".
- Ellipse ROI: if selected, the ROI is drawn by the trackball.

■ Standard ROI

1. Tap [Standard ROI] on the touch screen.
2. Browse the image to a desired frame.
3. When the trackball positions the cursor over the reference image(s), an elliptical ROI is automatically generated and displays on the reference image(s).
4. When scanning with an elliptical ROI, press <Set> to fix the ROI position and freeze its corresponding trace on the plot.

The average intensity value inside the ellipse is calculated for every image in the image analysis range and plotted in the image display area.

The last generated or selected ellipse is considered to be the active ROI, and its trace plot automatically updates as the user repositions it on the reference image.

A new active ROI is generated whose position is manipulated by the trackball and whose analysis curve traces will be plotted as before, while the previous ROI and trace remain fixed at the points they were saved at.

Press <Clear> to delete last ROI.

■ Ellipse ROI

1. Tap [Ellipse ROI] on the touch screen. When the cursor appears in the image review area (TVI image review window or 2D image review window), it displays as a color-coded ellipse.
2. Browse the image to a desired frame.
3. Use the trackball to position the caliper on the reference image at the start point. Press <Set> to fix the start point.
4. Trace the outline of the desired ROI by moving the cursor with the trackball.
5. Press the <Set> key, and roll the trackball to create the ROI. When a suitable ROI has been drawn, confirm the ROI by double-clicking the <Set> key. Press the <Clear> key to cancel the drawing.

■ Delete an ROI

Press the <Clear> key to clear the last ROI. Tap [Delete All] on the touch screen to clear all ROIs.

The corresponding traces for the deleted ROIs are erased from the plot.

Press <Clear> to delete the last added ellipse ROI.

■ Standard Height/Standard Width/Standard Angle

Use the touch screen selections [Std. Height], [Std. Width], [Std. Angle] to adjust the height, width and tilt angle of the standard ROI for the current or following ROIs.

ROI tracking

Tap [ROI Tracking] to be On to start tracking.

This function provides a motion-compensated ROI as precise time-intensity information can be acquired using active tracking.

Tip:

- Elliptical ROIs can be positioned in any way that keeps their center within the image boundaries. If part of the ROI is outside the image boundary, only data from within the image boundary is used for calculating the mean intensity value.
- When the user repositions an ROI, the old trace data is erased from the plot and the trace data for the new position re-plotted.

Export Trace Data

1. Tap [Export] on the touch screen.
2. Select the drive and enter the file name in the displayed window.

Select [OK] to save the data and return to the QA Analysis screen.

- All displayed ROI traces are saved in the exported file.
- The parameters are included in the trace file if the user has fixed a ROI.
- After exporting, a .BMP format image is displayed in the thumbnail area in the lower part of the screen.
- Only data from the user-selected image range is included in the exported trace file.

5.10 3D/4D

NOTE: 3D/4D imaging is largely environment-dependent, so the images obtained are provided for reference only, not for confirming diagnoses.

5.10.1 Overview

Ultrasound data based on three-dimensional imaging methods can be used to image any structure where a view can't be achieved by standard 2D-mode to improve understanding of complex structures.

4D provides continuous, high volume acquisition of 3D images. 4D adds the dimension of "movement" to a 3D image by providing continuous, real-time displays.

- Mode definition
 - Smart 3D
The operator manually moves the probe to change its position/angle when performing the scanning. After the scanning, the system carries out image rendering automatically, and then displays a frame of 3D image.
 - Static 3D
Posit the probe at a fixed place; the probe automatically performs the scanning. After the scanning is completed, the system carries out image rendering, and then displays a frame of 3D image.
 - 4D
The probe performs the scanning automatically. During the scanning, the system renders 3D images in real time, and all 3D images are displayed in real time.
- Terms
 - VR: a three-dimensional content.
 - Volume data: the image data set of a 3D object rendered from 2D image sequence.
 - 3D image: the image displayed to represent the volume data.
 - View point: a position for viewing volume data/3D image.
 - Section image: tangent planes of the 3D image obtained by algorithm. As shown in the figure below, XY-paralleled plane is C-section, XZ-paralleled plane is B-section, and YZ-paralleled plane is A-section. The probe is moved along the X-axis.
 - ROI (Region of Interest): a volume box used to determine the height and width of scanning volume.
 - VOI (Volume of Interest): a volume box used to determine the area of a sectional plane for 3D imaging.

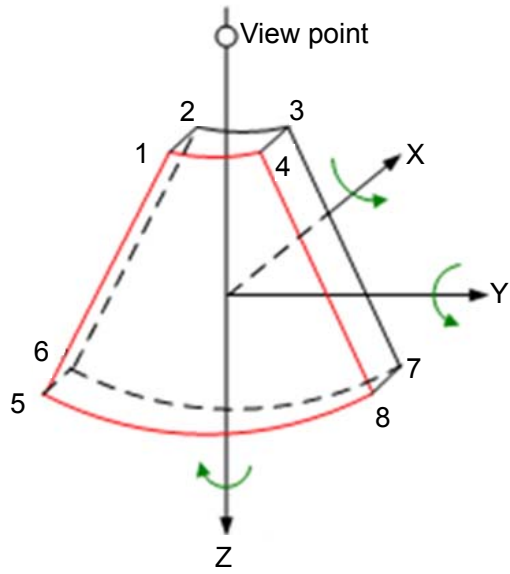

■ ROI and VOI

Before image acquisition after the system enters 3D/4D imaging, a B image with ROI displays on the screen. A line (shown in the following figure) that shows the cut plane position of VOI is inside ROI.

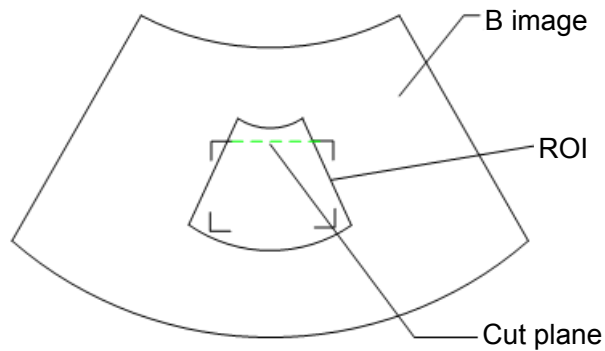

- ROI size and position
Roll the trackball to change the ROI size and position, press the <Set> key to toggle between setting the size (dotted line) and position (solid line, with a small box at each corner of ROI).
- Curved VOI adjustment
Roll the trackball to change the curved VOI position, press <Set> key to switch among the state of changing ROI and curve VOI.
This function is to change the curved shape of the nearest VOI section, to facilitate observation for the interested volume data.
It can be adjusted both in acquisition preparation status, and in A, B, C sections of review/ 4D imaging status, and a triangle of control point on the curved VOI is displayed.
Depending on the view direction, the orientation and the shape (line or dot) of curved VOI vary:

View	Curved VOI
U/D	At the upper part of curved VOI
D/U	At the lower part of curved VOI
L/R	At the left part of curved VOI
R/L	At the right part of curved VOI
F/B	Displays as a dot
B/F	Displays as a dot

NOTE: To define a ROI, please try to cut the useless data as to reduce the volume data, shortening the time for image storing, processing and rendering.

■ 3D view direction definition

You can adjust the view direction of the ROI.

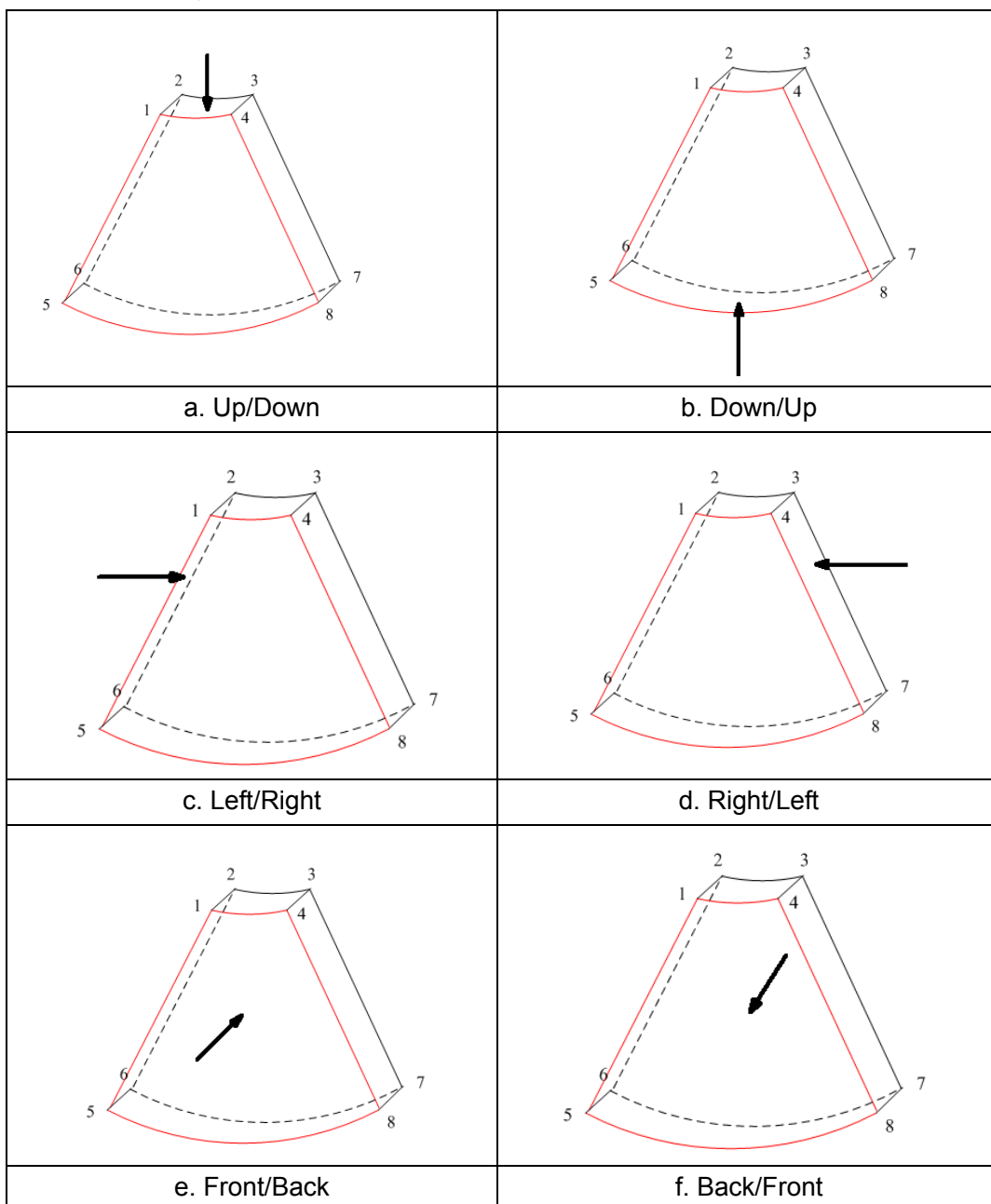

Tips: changing the view direction only changes the 3D/4D image; images of the 3 sections do not change.

■ Probe

A 2D imaging probe can be applied for Smart 3D imaging, however, to realize static 3D imaging or 4D imaging, a volume probe should be selected.

■ Sectional plane

The principle of 3D imaging is to render a 3D image from multiple 2D image information. The following describes the spatial relation of 3 sectional planes (A, B and C) and the 3D image.

The sectional plane can be viewed in the following status:

- 3D image viewing status of Smart3D
- 3D image viewing status of Static 3D
- Real time 4D or frozen 4D status

In the quad display format view, the screen displays A, B, C 3 sectional planes and the 3D image.

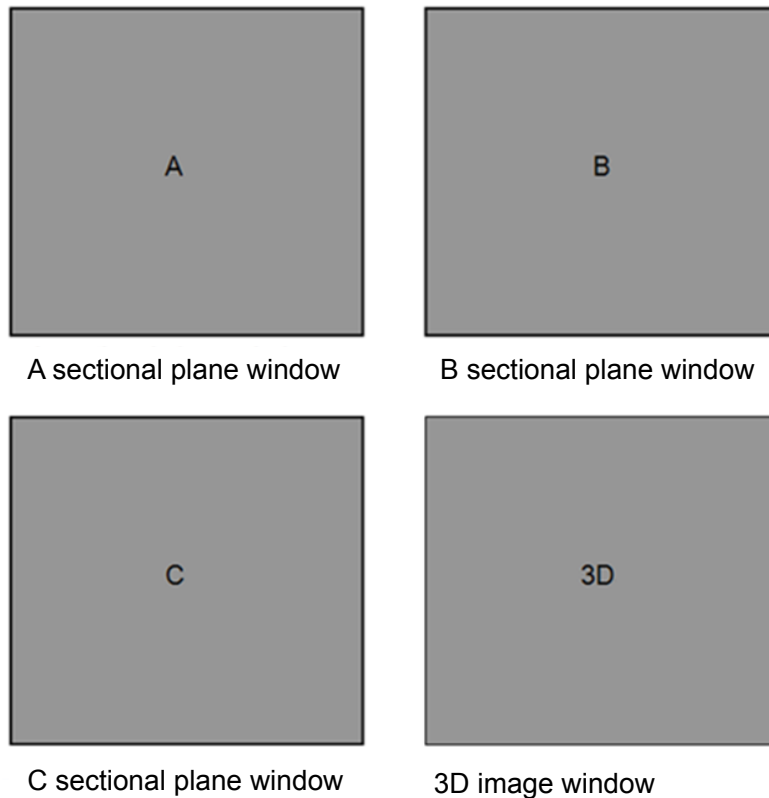

A, B, C section images are illustrated as the following sections of 3D image.

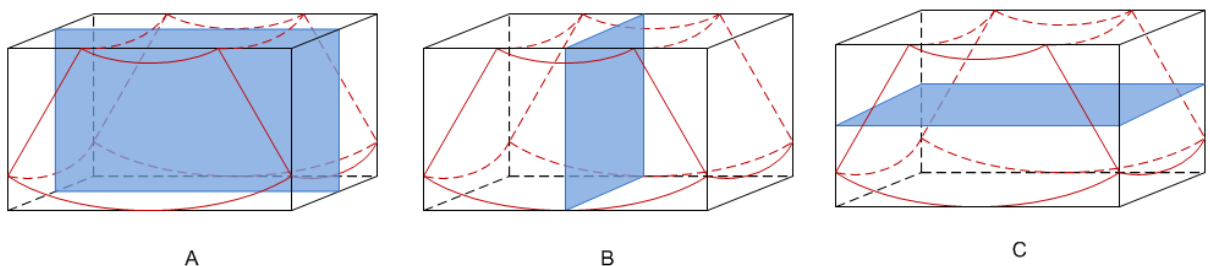

- Section A: corresponds to the 2D image in B mode. Section A is the sagittal section in fetal face up posture, as shown in the figure A above.

- Section B: it is the horizontal section in fetal face up posture, as shown in the figure B above.
- Section C: it is the coronal section in fetal face up posture, as shown in the figure C above.

Tips: the upper part of the 3D image in the D window is corresponding to the orientation mark on the probe, if the fetal posture is head down (orientating the mother's feet), and the orientation mark is orientating the mother's head, then the fetus posture is head down in the 3D image, you can make the fetus head up by rotating the 3D image by clicking [Quick Rot.] to be "180°" in the soft menu.

■ Wire cage

When you view a 3D/4D image on the display monitor, it's sometimes difficult to recognize the orientation. To help, the system displays a three-dimensional drawing to illustrate the orientation. Of which, the blue plane presents the image acquisition where started, while the red plane presents the image acquisition where ended, besides, a yellow plane in the wire cage presents the position of the sectional plane. See the graphic below:

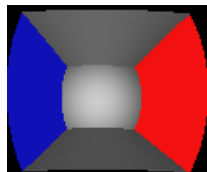

Wire Cage

CAUTION: The ultrasound images are provided for reference only, not for confirming a diagnosis. Please use caution to avoid misdiagnosis.

5.10.2 Note Before Use

5.10.2.1 3D/4D Image Quality Conditions

NOTE: In accordance with the ALARA (As Low As Reasonably Achievable) principle, try to shorten the sweeping time after a good 3D image is obtained.

The quality of images rendered in 3D/4D mode is closely related to the fetal condition, angle of a B tangent plane and scanning technique (only for Smart 3D). The following description uses fetal face imaging as an example. Imaging of other parts is the same.

■ Fetal Condition

(1) Gestational age

Fetuses of 24~30 weeks old are the most suitable for 3D imaging.

(2) Fetal body posture

Recommended: cephalic face up (Figure a) or face to the side (Figure b);

NOT recommended: cephalic face down (Figure c).

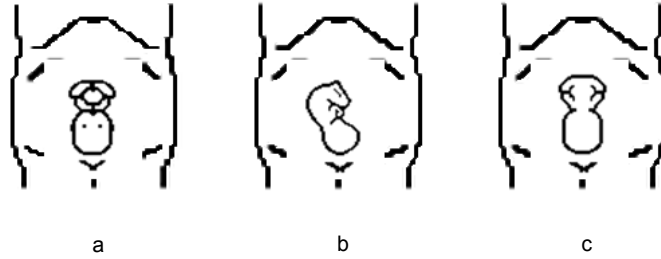

(3) Amniotic fluid (AF) isolation

The desired region is adequately isolated by amniotic fluid.

The region to be imaged is not obscured by limbs or umbilical cord.

(4) The fetus keeps still. If there is fetal movement, it is necessary to rescan.

■ Angle of a B tangent plane

The optimum tangent plane to the fetal face 3D/4D imaging is the sagittal section of the face. To ensure high image quality, scan the maximum face area and maintain edge continuity.

■ Image quality in B mode (2D image quality)

Before entering 3D/4D capture, optimize the B mode image to ensure:

- High contrast between the desired region and the surrounding AF.
- Clear boundary of the desired region.
- Low noise of the AF area.

■ Scanning technique (only for Smart 3D)

- Stability: the body, arm and wrist must move smoothly, otherwise the restructured 3D image distorts.
- Slowness: move or rotate the probe slowly.
- Evenness: move or rotate the probe at a steady speed or rate.

NOTE:

1. A region with a qualified image in B mode may not be optimal for 3D/4D imaging. E.g., adequate AF isolation for one MPR does not mean the whole desired region is isolated by AF.
2. Practice is needed for a high success rate of qualified 3D/4D imaging.
3. Even with good fetal condition, acquiring a suitable 3D/4D image may require more than one scanning.

5.10.3 Static 3D

Static 3D provides single frame image acquisition of 3D images. During scanning, the probe performs the scanning automatically.

5.10.3.1 Basic Procedures for Static 3D Imaging

To perform Static 3D imaging:

1. Select the appropriate probe and exam mode. Make sure there is sufficient gel on the probe for scanning.
2. Obtain a 2D image.

Make sure there is:

- High contrast between the desired region and the surrounding AF (amniotic fluid).
 - Clear boundary of the desired region.
 - Low noise of the AF area.
3. Press <3D> to enter Static 3D acquisition preparation mode, and define the ROI as well as the curved VOI.

To adjust the ROI:

- Under acquisition preparation status: roll the trackball to change the ROI size, ROI position and curved VOI, press the <Set> key to toggle between setting the ROI size, ROI position and curved VOI.
- Draw a circle around the interested region, then the system will position the ROI to cover the region. You can adjust ROI size and position if necessary.

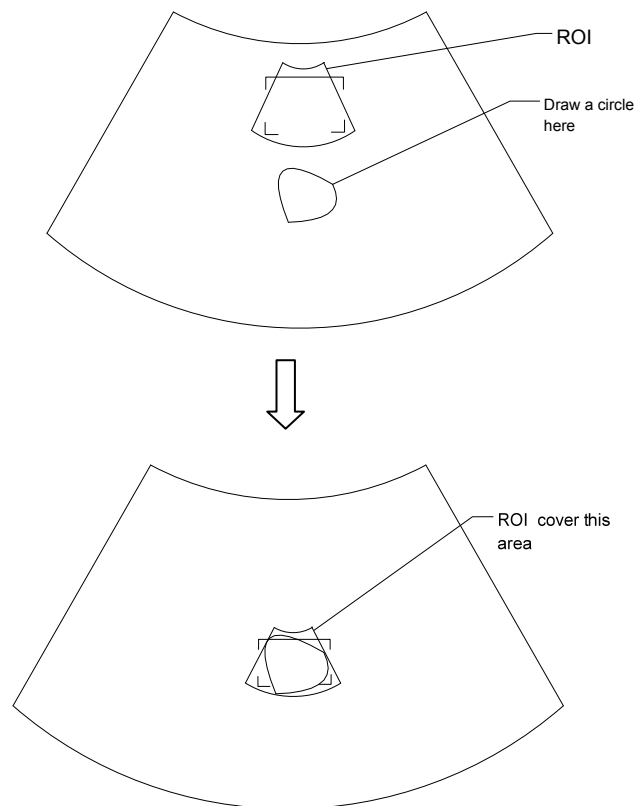

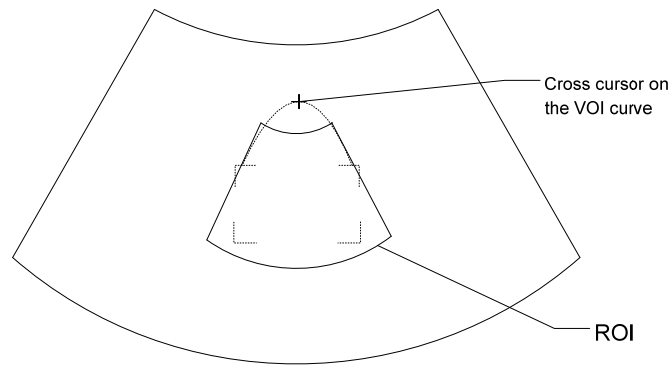

For setting the ROI, be sure to:

- Set the ROI on the 2D image with the largest section area of the fetal face.
- Set the ROI a little larger than the fetal head.

NOTE: When defining an ROI, try to eliminate useless data so as to reduce the volume data and shorten the time for image storing, processing and rendering.

4. Select a render mode on the touch screen and set parameters such as [Angle] and [Image Quality] on the touch screen accordingly.
5. Press <Update> on the control panel to start the 3D image acquisition.
The system enters 3D image viewing status when the acquisition is completed.
In image viewing status, you can perform VOI setting, image editing and other operations. For details, see “5.10.3.3 Static 3D Image Viewing.”
6. Exit Static 3D.
Press or <3D> to enter B mode.

5.10.3.2 Static 3D Acquisition Preparation

Description of parameters:

Type	Parameter	Description
Parameter adjusting	Angle	Function: to set the range for imaging. Range: 10-80°.
	Quality	Function: to adjust the image quality by changing the line density. Image quality can affect the imaging speed: the better the image quality, the longer the time. Range: Low2, Low1, Mid, High1, High2
Render Mode	Surface	Function: set Surface as the 3D image rendering mode. This is useful for surface imaging, such as fetus face, hand or foot. Tip: you may have to adjust the threshold to obtain a clear body boundary.
	Max.	Function: set Max. as the 3D image rendering mode. Displays the maximum echo intensity in the observation direction. This is useful for viewing bony structures.

Type	Parameter	Description
	Min.	Function: set Min. as the 3D image rendering mode. Displays the minimum echo intensity in the observation direction. This is useful for viewing vessels and hollow structures.
	X-ray	Function: set X-ray as the 3D image rendering mode. Displays the average value of all gray values in the ROI. X Ray: used for imaging tissues with different internal structures or tissues with tumors.

5.10.3.3 Static 3D Image Viewing

Enter/Exit Image Viewing

- To enter image viewing:
The system enters image viewing when image acquisition is complete.
- Exit
To return to 3D/4D image acquisition preparation status, press <Update> or <Freeze>.

Activate MPR

Tap [A], [B], [C] or [VR] to activate MPR or 3D image (VR).

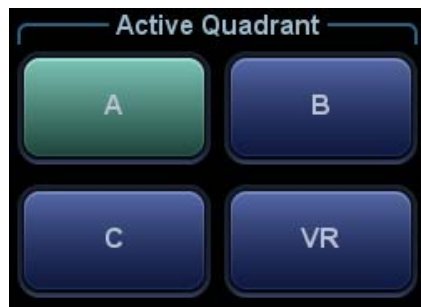

MPR Viewing

In the actual display, different colors for the window box and the section line are used to identify the MPR A, B and C.

- Window A is blue, and the lines (representing MPR A) displayed in the other two windows are also blue.
- Window B is yellow, and the lines (representing MPR B) displayed in the other two windows are also yellow.
- Window C is orange, and the lines (representing MPR C) displayed in the other two windows are also orange.

The positions of the other two MPRs are indicated in the selected plane. You can roll the trackball to change the position.

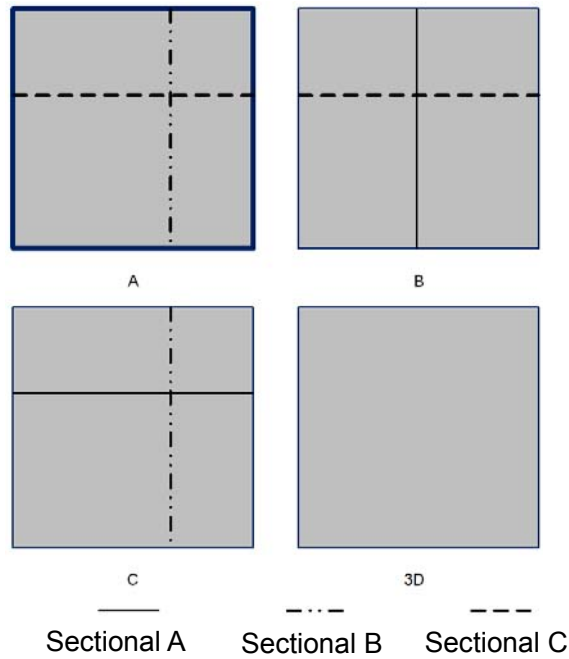

MPR Only



Tap  on the touch screen to display MPR only. The adjustable image parameters are changed to MPR parameters automatically.

Only A, B and C MPR are displayed, and VR is not displayed.

The MPR Only function is available in image acquisition status.

Asymmetric



Tap  on the touch screen to display MPR along with VR. A larger VR image along with 3 small MPR images will be displayed.

View Direction

The Region of Interest (ROI), also referred to as the Render Box in rendering, contains the section of the volume you want to render. Therefore, objects that are not inside the box are not included in the render process and are cut out (this is important in surface mode to allow a free line of sight). This may or may not be the entire VOI.

You can adjust the view direction of the ROI.

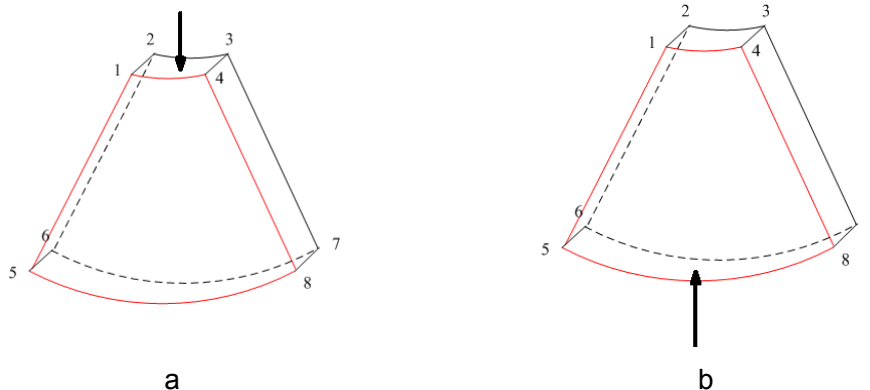

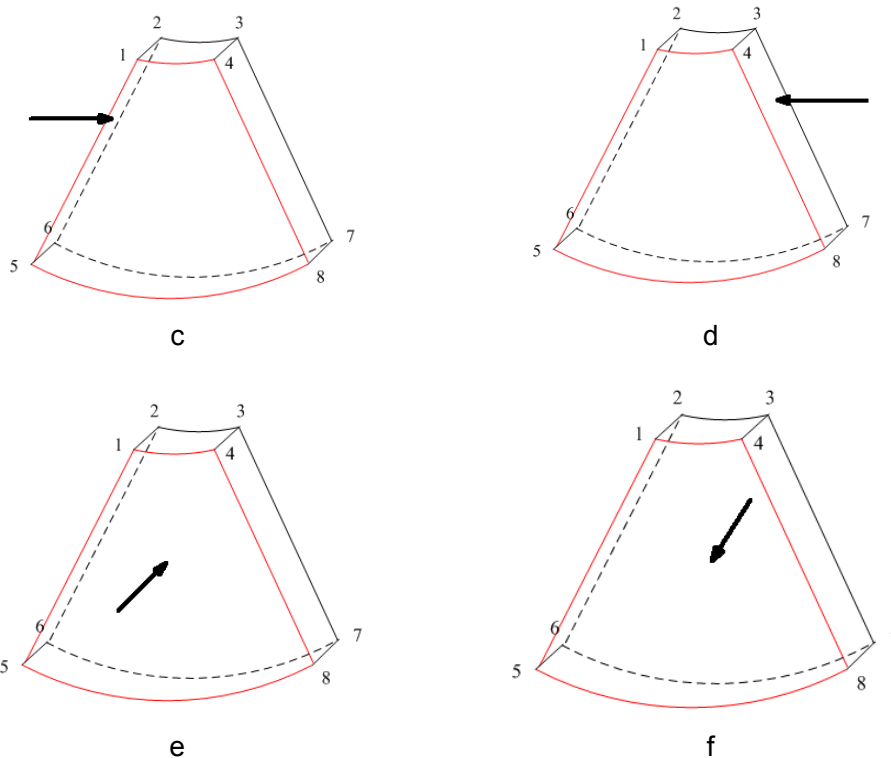

View Direction

a. Up/Down	b. Down/Up
c. Left/Right	d. Right/Left
e. Front/Back	f. Back/Front

Tap [U/D], [L/R] or [F/B] on the second page of the touch screen to select the direction of the above Figure a, c and e.

Tap [Flip] on the touch screen to view in the opposite direction to the current direction, as shown in Figures b, d and e.

Adjust VOI

■ VOI On

The VR image displays VOI information.

1. In image viewing status, tap [VOI] to turn it to "On."
2. Select the desired window by touching [A], [B] or [C] or [VR].
3. Roll the trackball to adjust the VOI position, size and curved VOI, and press <Set> to switch between the adjusting status. Or rotate the <4D> knob on the control panel to adjust the relative position of MPRs so as to slice through the VR.

■ VOI Off

The VR image displays ROI information.

Tap [VOI] to turn it to "Off." The ROI image is displayed on the screen. Roll the trackball to observe the MPR.

■ Accept VOI

1. This function is usually used for MPR observation and to determine the relative position of the MPR to the VR.
2. Tap [Accept VOI] on the touch screen.
3. Select the desired MPR by touching [A], [B] or [C] or [VR].

- Roll the trackball to view the current active MPR. The other two MPRs change correspondingly. Or rotate the <4D> knob to adjust the relative position of MPRs so as to slice through the VR.



In Accept VOI status, when the VR is active or the MPR which is perpendicular to the view direction is active, the center point of the VR displays. Adjust the position using the trackball.

Image Rendering Parameters

In image viewing status, render the image by adjusting the relevant parameters.

Render setting parameters description:



Tap  or  on the touch screen to select VR or MPR parameter adjustments.

- When [VR] is highlighted in green, parameter adjustment is performed on the VR image.
- When [MPR] is highlighted in green, parameter adjustment is performed on the MPR.

Adjustable parameters are as follows:

Parameter	Description
Threshold	<p>Function: to set the threshold for VR rendering. The VR is rendered using the signal between the high and low thresholds.</p> <p>When signals are received, from small to large, they are divided into different levels assigned within the range of 0-100%. The threshold is a selected range where the system filters out signals below it and above it to render the VR image.</p> <p>The lower threshold can eliminate lower range noises and echo, which contributes to a clearer and smoother image.</p> <p>Range: 0%-100%.</p> <p>Available in Surface render mode only.</p>
Opacity	<p>Function: to set the transparency value for VR rendering.</p> <p>Range: 0%-100%.</p> <p>The lower the number, the more transparent the grayscale information.</p>
Smooth	<p>Function: to set the smoothness of VR.</p> <p>Selection: 0-20. 0 refers to no smooth effect, 0-20 represent 21 effects in incremental order.</p> <p>Tip: Insufficient smoothness can result in a fuzzy image, while too much smoothness will lead to image distortion.</p>
Bright	<p>Function: to set the brightness of VR.</p> <p>Range: 0%-100%. 0% represents the minimum brightness, while 100% represents the maximum.</p>
Contrast	<p>Function: to set the contrast of VR.</p> <p>Range: 0%-100%.</p>
Tint	<p>Switch tint map on/off. Selection: Off, 1-25.</p>
VR Orientation	<p>To quickly rotate the VR.</p> <p>Selection: 0°, 90°, 180°, 270°.</p>

Parameter	Description
iClear	Enhances the B mode image profile for better boundary details. Range: Off, 1-4.

■ Reset Curve

Parameter	Description
Reset Ori.	To reset the volume rotation, shifting and zooming to its original status.
Reset Curve	To reset the curve to its original status.
Reset All	To reset the volume to its original orientation and original parameters.

■ Render Mode



Parameter	Description
Gray/Inversion	Surface Function: set Surface as the VR rendering mode. This is useful for surface imaging, such as fetus face, hand or foot. Tip: you may have to adjust the threshold to obtain a clear body boundary.
	Max. Function: set Max. as the VR rendering mode. Displays the maximum echo intensity in the observation direction. This is useful for viewing bony structures.
	Min. Function: set Min. as the VR rendering mode. Displays the minimum echo intensity in the observation direction. This is useful for viewing vessels and hollow structures.
	X-ray Function: set X-ray as the VR rendering mode. Displays the average value of all gray values in the ROI. X Ray: used for imaging tissues with different internal structures or tissues with tumors.
The above four rendering methods can be applied to both gray and inversion modes. Where inversion means to invert the grayscale of the image, so as to enhance observation for low-echo regions, applicable for vessels, cysts, etc. When the function is turned on, the rendering mode parameters change to the corresponding inverse parameters.	

Rotate an Image

The system supports the following rotation modes:

- Axial rotation
- Auto rotation
- Axial rotation
 - Axial rotation rotates the currently activated image around the X-, Y- or Z-axis.
 - Procedures
 - a) Select the current image.
 - b) Rotate the corresponding knobs to make the image rotate:
 - To rotate along the X-axis: rotate the <M> button on the control panel clockwise and the image rotates right along the X-axis. Rotate the button counter-clockwise and the image rotates to the left.
 - To rotate along the Y-axis: rotate the <PW> button on the control panel clockwise and the image rotates right along the Y-axis. Rotate the button counter-clockwise and the image rotates to the left.
 - To rotate along the Z-axis: rotate the <Color> button on the control panel clockwise and the image rotates right along the Z-axis. Rotate the button counter-clockwise and the image rotates to the left.
- Auto rotation
 - (1) In 3D viewing mode, tap the [Auto Rot.] tab on the touch screen. The system enters the auto rotation preparation state.
 - (2) Tap [L/R] or [U/D] to set the auto rotation direction.
 - (3) Set the Start position and End position:

Start position: roll the trackball to view at a certain position. Press the trackball “Set Start” function key according to the trackball hint area.

End position: roll the trackball to view at a certain position. Press the trackball “Set End” function key according to the trackball hint area.
 - (4) Set the rotation mode: tap  for single direction rotation, and tap  for bidirectional rotation.
 - (5) Tap [Speed] to set the rotation speed.
 - (6) Tap  to activate rotation.
 - (7) Tap [Step] to set the rotate step.

NOTE: You can view the back of the VR by rotating it 180°. The back view image may not be as vivid as the front. (Here we call the initial view of the VR the “front”). It is recommended to re-capture rather than rotate the VR if a certain desired region is obscured in the VR.

Image Zooming

To adjust the zoom factor of VR. The sectional images will be zoomed in/out accordingly.

- Operation
 - Set the VR window as the current window.
 - Press <Zoom> to increase or decrease the magnification factor.

Sync

This function switches the view direction perpendicular to the current active plane, so as to get a better view of VR.

In the following image, the current active plane is MPR A. After performing Sync on Figure A, you can see the same fetal face profile in VR.

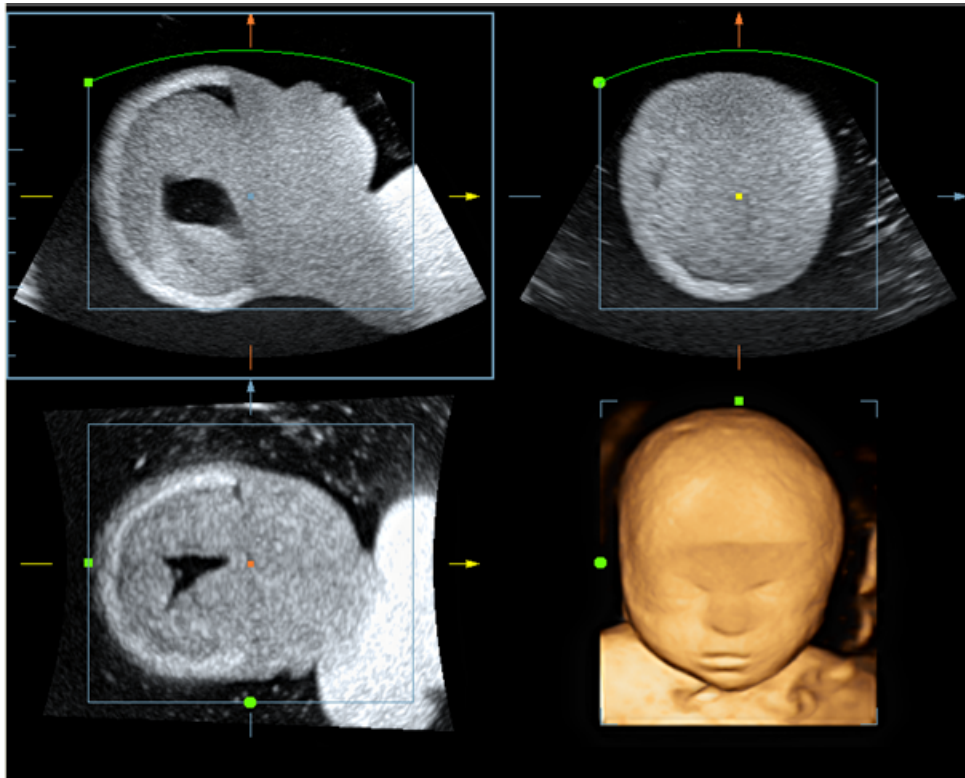

Figure A

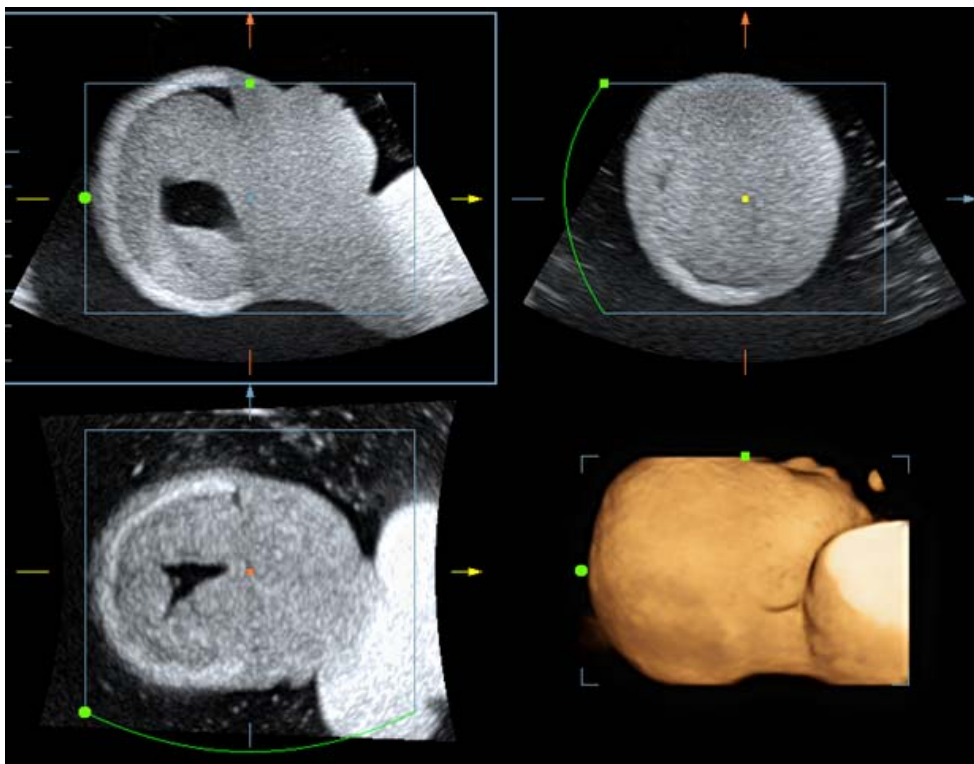



Figure B

Comments and Body Marks

- Function:
Add comments and body marks to the MPR and VR.
- Operation:
The operation is the same as adding comments and body marks in B image mode.

Image Editing

- Function
Image editing is a more elaborate function than VOI adjusting for optimizing the 3D image by clipping (removing) the obscured part of the region of interest.
Tip:
 - In image editing status, no image parameters can be changed. A cutting cursor is displayed  or an eraser cursor , and the system enters "Accept VOI" status.
 - The editing function is available only on VR.
- Procedures
 1. Enter image editing status by touching the [Edit] tab.
 2. Select an edit tool:
 - Polygon
 - a) Press <Set> to position the start point, roll the trackball to set a region, and press <Set> to trace the region.
 - b) When the start point and end point coincide, the region is selected, or press <Set> twice to finish tracing.
 - c) Move the cursor to the region you want to cut and press <Set> again to cut.
 - Contour
 - a) Press <Set> to position the start point, and roll the trackball to trace the region.
 - b) When the start point and end point coincide, the region is selected, or press <Set> twice to finish tracing.
 - c) Move the cursor to the region you want to cut and press <Set> again to cut.
 - Rectangle
 - a) Press <Set> to fix the rectangle's position, roll the trackball to change the size, and press <Set> again to finish drawing the rectangle.
 - b) Move the cursor to the region you want to cut and press <Set> again to cut.
 - To undo the last cutting, tap [Undo] on the touch screen.
 - To undo all cuttings, tap [Undo All].

The image cutting parameters are described as follows:

Type	Parameters	Description
Edit Type	CTR. In	Allows you to trace the portion of the image you want to cut. Inside Contour removes all portions of the image that fall inside your traced region.
	CTR.Out	Allows you to trace the portion of the image you want to cut. Outside Contour removes all portions of the image that fall outside your traced region.

Type	Parameters	Description
	Rect. In	Displays a box you can use to define the portion of the image you want to cut. Inside Rect removes all portions of the image that fall inside of the box.
	Rect. Out	Displays a box you can use to define the portion of the image you want to cut. Outside Rect removes all portions of the image that fall outside of the box.
	Poly. In	Allows you to trace a polygon on the image you want to cut. Inside Polygon removes all portions of the image that fall inside your traced region.
	Poly. Out	Allows you to trace a polygon on the image you want to cut. Outside Polygon removes all portions of the image that fall outside your traced region.
Other Operations	Undo	To undo the last cut only.
	Undo All	To undo all cuts since you entered image edit mode.

■ Section image (MPR) measurement.

2D related measurements can be performed on MPR. For details, see [Advanced Volume].

Measurement is not available in acquisition preparation status.

5.10.3.4 Image Saving and Reviewing in Static 3D

■ Image saving

- In 3D viewing mode, press the single image Save key (Save Image to hard drive) to save the current image to the patient information management system in the set format and image size.
- Save clip: in 3D viewing mode, press the user-defined Save key (Save Clip (Retrospective) to hard drive) to save a CIN-format clip to the hard drive.

■ Image review

Open an image file to enter the image review mode. In this mode, you can perform the same operations as in VR viewing mode.

5.10.4 iLive

iLive brings you a better imaging experience by adding a light rendering effect to the traditional method. It supports the global lighting mode as well as the partial scattering mode, allowing human tissue texture to be revealed more clearly.

iLive is an option, and is available under Smart 3D, Static 3D and 4D modes. To use the iLive function, you must configure the Smart 3D module or the 4D module.

■ To Activate iLive

1. Enter 3D/4D image viewing status, or double-click the saved 3D/4D cine file in the iStation or Review screen.
2. Tap [iLive] on the second page of the touch screen to turn the function on, and adjust the parameters.

■ Imaging using iLive

1. Select the imaging mode:
 - Use the ordinary probe and press <3D> to enter Smart 3D.

- Or, use 4D probe and press <4D> to enter 4D mode or Static 3D mode.
2. Select the render mode to be iLive by touching the touch screen, and set the related parameters (quality and angle, etc.).
 3. Press <Update> to begin acquisition.
 4. The system finishes acquisition and enters the image viewing screen.
In image review status, you can perform operations such as VOI setting, image editing, comment adding, body mark adding, etc.
 5. Or press or toggle <4D> to exit the mode.

5.10.4.1 Operation Controls

Adjustable parameters for iLive are on the second page of the touch screen.

■ Shading

Adjusts the effect of shadowing and scattering. When the selected level is 0, the rendered image will be bright and sharp, and the shadow border will be clear while the area of the shadow will be relatively small. As the level increases, the rendered image will become warmer but the details remain the same. Also, the shadow border will be smoother while the shadow area will be large.

■ Light source adjustment

This function adjusts the position of the light source toward the VR image.

- Select the direction by touching the buttons under the “Light Position” box.

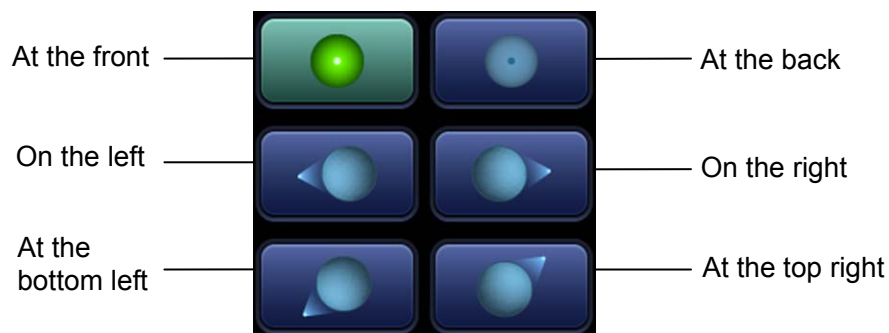

■ Soft View

Using this function, an even smoother rendered surface can be observed. This function smooths volumes with a larger kernel while the 3D/4D imaging [Smooth] parameter changes the mix ratio between the unsmoothed data and the smoothed data. Using Soft View, some trivial noise structures will be suppressed and the surface will become smoother. However, Soft View may also suppress the details of volumetric surfaces.

■ Grad View

After this function is activated, VR details will be revealed and enhanced.

Other operation controls and adjusting methods are similar to those in 3D/4D mode.

Other Operations

iLive does not support Inversion mode.

■ Zoom

Same as in 3D/4D mode.

- **Rotation**

Roll the trackball to view sectional images as necessary. Rotate <M>, <PW>, <C> to perform axial rotation or rotate the <4D> knob to adjust the nearest VOI section (cut plane) position.

- **Comments and Body Marks**

Same as in other modes.

5.10.5 4D

4D provides continuous, high-volume acquisition of 3D images. During scanning, the probe performs the scanning automatically.

4D image acquisition operations are similar to those of Static 3D. The only difference is that in static 3D mode, only a single frame 3D image is captured, while in 4D mode, continuous, high-volume acquisition of 3D images is provided.

4D imaging is an option.

5.10.5.1 Basic Procedures for 4D Imaging

1. Select the appropriate 4D-compatible probe and exam mode. Make sure there is sufficient gel on the probe for scanning.
2. Obtain a 2D image as described in the Static 3D imaging procedure.
3. Press <4D> to enter 4D imaging preparation status. Define the ROI as well as the curved VOI. For details, see “5.10.3.1 Basic Procedures for Static 3D Imaging.”
4. Select a render mode, and set parameters.
5. Press <Update> on the control panel to enter the 4D image real-time display status.
6. Press <Freeze> on the control panel to freeze the image. Perform image cutting, rotation, annotation and image saving if necessary. For detailed operations, see “5.10.3.3 Static 3D Image Viewing.”
7. Exit 4D.
Press <Update> to return to 4D image acquisition preparation, or, press or the <4D> key to enter B mode.

5.10.5.2 4D Acquisition Preparation

The parameters are the same as those for Static 3D. For details, see “5.10.3.2 Static 3D Acquisition Preparation.”

5.10.5.3 4D Real-time Display

In 4D real-time display status, operations are similar to those in Static 3D. For details, see the corresponding section in Static 3D.

4D Real-time Editing

You can remove unnecessary information from the VR in real-time scanning by using a line tool.

1. In 4D real-time imaging, tap [Edit] on the touch screen to enter the status.
 2. Select the starting point in the VR and press <Set>.
 3. Rotate the trackball to adjust the orientation, and press <Set> again to define the cutting boundary.
 4. Move the cursor to the region you want to remove and press <Set> to remove it.
- Tap [Undo] or [Undo All] to restore the operations.

5.10.5.4 4D Image Saving

- In 3D viewing mode, press the single image Save key (Save Image to hard drive) to save the current image to the patient information management system in the set format and image size.
- Save clip: in 3D viewing mode, press the user-defined Save key (Save Clip (Retrospective) to hard drive) to save a CIN-format clip to the hard drive.

Tip: After freezing a 4D image, press <Cine> to switch between cine auto-play mode and manual mode.

5.10.5.5 3D/4D Fast Switching

In 4D real-time imaging mode, press <3D> to quickly switch to VR viewing status, where you can obtain the same image of a better quality.

5.10.6 Smart 3D

The operator manually moves the probe to change its position/angle when performing the scan. After scanning, the system carries out image rendering automatically, then displays a frame of the 3D image.

Smart 3D is an option.

5.10.6.1 Basic Procedures for Smart 3D Imaging

NOTE: In Smart 3D image scanning, if the probe orientation mark is oriented to the operator's finger, perform the scan from right to left in linear scan, or rotate the probe from left to right in rocked scanning. Otherwise, the VR direction will be wrong.

To perform Smart 3D imaging:

1. Select the appropriate probe (non-4D probe) and exam mode. Make sure there is sufficient gel on the probe for scanning.
2. Obtain a 2D image. Optimize the image as described in the Static imaging procedure.
3. Press <3D> to enter the Smart 3D imaging preparation status, and define the ROI as well as the curved VOI.
4. Select a render mode.
5. Select an acquisition method, and set the corresponding parameters on the touch screen.
Rocked mode: set [Angle] parameter.
Linear mode: set [Distance] parameter.
6. Press <Update> on the control panel to start the 3D image acquisition.
The system enters the 3D image viewing status when the acquisition is complete. Or, end the acquisition by pressing <Freeze> or <Update> on the control panel.
In image viewing status, operations such as VOI setting and image editing can be performed. For details, see "5.10.3.3 Static 3D Image Viewing."
7. Exit Smart 3D.
Press <Update> or <Freeze> to return to Smart 3D image acquisition preparation. Or, press or <3D> to enter B mode.

5.10.6.2 Smart 3D Acquisition Preparation

In Smart 3D mode, you need to set the scan method in addition to the other items in Static 3D mode. The other parameters are the same as those for Static 3D. For details, see “5.10.3.2 Static 3D Acquisition Preparation.”

■ Method

Capture images using Linear scan or Rocked scan.

● Linear scanning

Move the probe across the surface. See the following figure.



● Rocked scanning

Rotate the probe once from the left to the right side (or from the right to the left) to include the entire desired region. See the figure.

■ Description of parameters:

Parameter	Description
Method	<p>Function: select the image acquisition method.</p> <p>Selection: Rocked, Linear.</p> <p>Linear mode: during the sweep, the probe must be kept parallel. The scanning speed should be constant.</p> <p>Rocked mode: in this mode, the probe must be moved to a position where you can clearly see a middle cut of the object you want to scan and render. Tilt the probe to about 30 degrees until the object you want to scan disappears. Start the acquisition and tilt the probe over a distance of around 60 degrees until the object disappears again. During the sweep, the probe may not be moved parallel, just tilted.</p> <p>Tip: the speed is related to scanning distance or angle.</p>
Distance	<p>Function: to set the distance the probe covered from one end to the other end during a linear sweep.</p> <p>Range: 10-200 mm, in increments of 10 mm.</p>
Angle	<p>Function: to set the angle the probe covered during a fan sweep.</p> <p>Range: 10-80°, in increments of 2°.</p>

5.10.6.3 Smart 3D Image Viewing

In VR viewing, the system supports the following functions:

- Render setting.
 - B-mode parameter adjustment.
 - Setting the display format.
 - Viewing MPR.
 - Image zooming.
 - Rotation.
 - Image editing.
 - VR parameter adjustment.
- Scanning plane and probe movement

Move the probe across the body surface.

The arrow in the figure below indicates the movement of the probe (you can move the probe in the opposite direction to the arrow.).

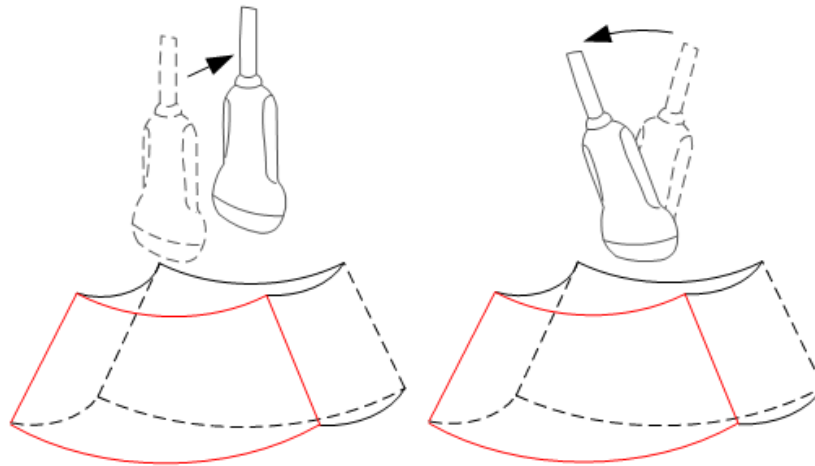

5.10.6.4 Image Saving and Reviewing in Smart 3D

- Image saving
- In 3D viewing mode, press the single image Save key (Save Image to hard drive) to save the current image to the patient information management system in the set format and image size.
 - Save clip: in 3D viewing mode, press the user-defined Save key (Save Clip (Retrospective) to hard drive) to save a CIN-format clip to the hard drive.
- Image review

Open an image file to enter the image review mode. In this mode, you can perform the same operations as in VR viewing mode.

5.10.7 iPage (Multi-Slice Imaging)

iPage is a new “Visualization” mode for displaying sectional images. The data is presented as slices through the data set, which are parallel to each other.

iPage is an option and is not available for Smart 3D images.

5.10.7.1 Basic Procedures for iPage

1. Acquire 3D/4D data.

- Single-frame VR:
 - 4D mode: freeze the system, then roll the trackball to select the image.
 - Static 3D: an image frame is acquired automatically after the acquisition is completed.
 - Multi-frame 3D images: acquire multiple 3D images in 4D imaging mode.
2. Perform operations such as rotation and VOI adjusting to the image to find the region of interest.
 3. Tap [iPage] tab on the touch screen to enter iPage mode.
 4. Check the A/B/C sectional planes and select the reference image.
 5. Confirm whether the slices displayed are the target planes. If not, re-select the reference image again.
 6. Observe the interested structure through multiple slices.
 Select the proper image layout and space according to the size of the target structure.
 To view the details or a tiny part of the region of interest, use image zooming.
 7. Rotate the 3D image to observe the slices of other orientations. Repeat step 6 if necessary.
 If the target orientation and region cannot be observed even after image rotation and shifting, tap [Reset Ori.] to reset the 3D image.
 8. Perform operations such as commenting on the region of interest.
 9. Save the image as required.

5.10.7.2 iPage Basic Functions and Operations

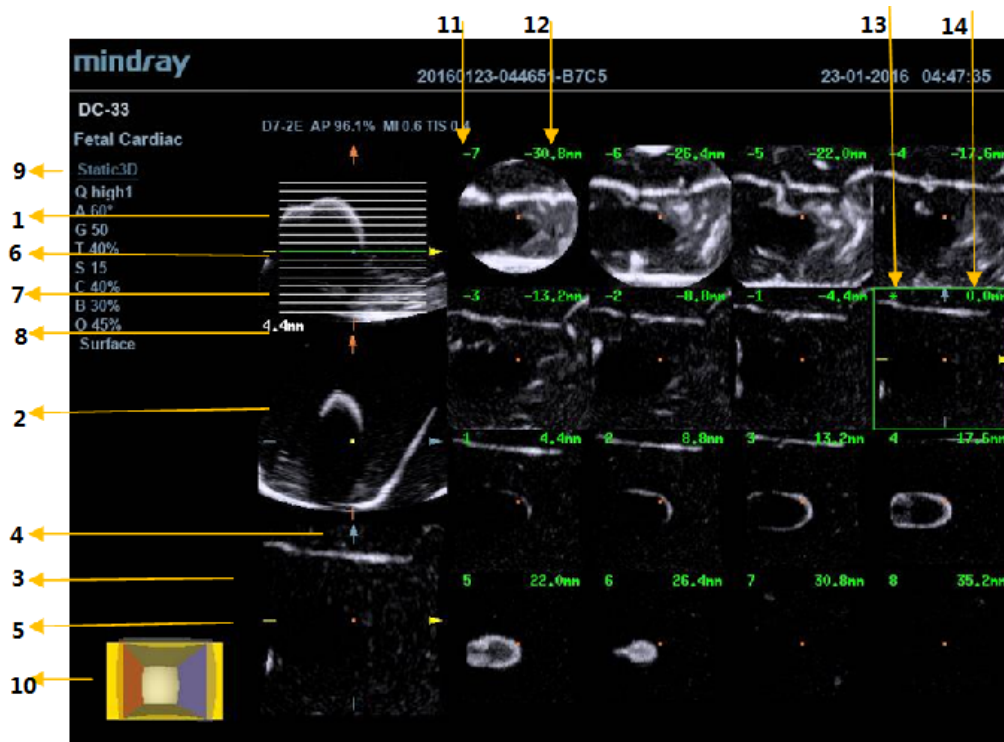

<1>	A plane	<2>	B plane (the current reference image)	<3>	C plane
<4>	Y-axis	<5>	X-axis	<6>	Central section line (Current active section line)
<7>	Section line	<8>	Space between two planes	<9>	Image parameter
<10>	Wire cage	<11>	Section plane order number	<12>	Section plane position (to the central plane)
<13>	Central plane mark	<14>	Green box on the active image		



■ Layout

The system supports several types of display layout: 2*2, 3*3, 4*4 and 5*5. Tap the corresponding icon on the touch screen to select, and the selection [Slice Number] changes accordingly.

■ Reference image

Tap [A], [B] or [C] to select the reference image.

■ Slice and slice line

- Central slice: the central plane which corresponds to the central slice line is the central slice, marked with a green “*” in the top-left corner of the image.
- Tap  to position the slice lines vertically, and tap  to position the slice lines horizontally.
- Active slice: the central plane which corresponds to the green slice line is the active slice, marked with a green box. The default active slice is the central slice.

- Slice order number: indicates the order of the slices. The position of the central slice is “0”, the slices before the central slice are marked with negative integral numbers, and the slices after the central slice are marked with positive integral numbers.
 - Slice position (to the central slice): displayed in the top-left corner of each image, indicating the position of each image (such as -7 mm, -3 mm, 3 mm, 8 mm).
 - Coordinate axis: indicated on the three A, B, C reference images. Correspond to the central slice line, and will move accordingly with the central slice line.
- Slice shifting

Roll the trackball to shift the crossing point of the central axis up/down and left/right. The slice lines will shift accordingly with the crossing point.

Rotate the knob under [Range Pos.] on the touch screen to fine-tune slice lines horizontally.
 - Slice position

Rotate the knob under [Slice position] to move the active slice line (green) either forward or backward within the range. The corresponding slice will be highlighted in green.
 - Spacing

The value is displayed on the top-left side of the slice. Unit: mm. Adjust it using the knob under the touch screen selection [Spacing]. The adjusting range is from 0.1 mm to 20 mm.
 - Slice numbers

Change slice numbers as necessary using the knob under [Slice Number] on the touch screen.
 - Image rotation

Rotate <M>, <PW> and <Color> to perform axial rotation or rotate the <4D> knob to adjust the nearest VOI section (cut plane) position.

For details, see the descriptions in Static 3D.
 - Image zooming

Same as Static 3D image zooming.
 - Hide/show reference image

The system displays 3 standard sectional images (A plane, B plane, C plane) on the left side indicating the position of the slice lines. Tap  to hide the 3 reference images, then slices are displayed on the whole image area.
 - Quick switch to single display

Select a particular slice, double-press <Set> to see the slice in full screen, then double-press<Set> again to return to the original display format.
 - Reset Ori.

Tap [Reset Ori.] to reset the orientation and zoom status of the image.
 - Comments & Body Marks

The operations are the same as those in the other modes.
 - Measurement

Measurement can be done on any slice when it is in the single format display.

5.11 iScape View (Real-time Panoramic Imaging)

The iScape panoramic imaging feature extends your field of view by piecing together multiple B images into a single, extended B image. Use this feature, for example, to view a complete hand or thyroid.

When scanning, move the probe linearly and acquire a series of B images. The system pieces these images together into a single, extended B image in real time. The system also supports out-and-back image piecing.

After obtaining the extended image, you can rotate it, move it linearly, magnify it, add comments or body marks, or perform measurements on the extended image.

The system provides a color iScape function, so you can get more information from extended images.

iScape View imaging is an option.

 CAUTION:	<ol style="list-style-type: none">iScape panoramic imaging constructs an extended image from individual image frames. The quality of the resulting image is user-dependent and requires operator skill and additional practice to become fully proficient. Therefore, the measurement results can be inaccurate. Exercise caution when you perform measurements in iScape mode. A smooth and even speed will help produce optimal image results.Color iScape images are provided for reference only, not for confirming diagnoses.
---	---

Tip:

- iScape is an optional module, the function is available only if the module has been installed on the ultrasound system.
- Displaying the biopsy guideline is not allowed in iScape mode.

5.11.1 Basic Procedures for iScape Imaging

To perform iScape imaging:

1. Connect an appropriate iScape-compatible probe. Make sure there is enough coupling gel along the scan path.
2. Set the user-defined key for iScape via the path: [Setup]→[System]→[Key Config]. Press the user-defined key for iScape on the control panel to enter iScape (to acquire color iScape images, enter iScape mode from B+Power mode), or tap [iScape View] on the touch screen directly:

3. Optimize the B mode (Power mode) image:

In the acquisition preparation status, touch the [B] ([Power]) page tab to select B mode (color) image optimization. Perform measurement or add comments/body marks to the image if necessary. Tip: in iScape mode, [FOV] is limited to "W."

4. Image acquisition:

Click the [iScape] page tab to enter the iScape acquisition preparation status. Click [Start Capture] or press <Update> on the control panel to begin the acquisition. For details, see "5.11.2 Image Acquisition."

The system enters image viewing status when the acquisition is completed. You can perform operations such as parameter adjusting. For details, see "5.11.3 iScape Viewing."

5. Exit iScape:

- Press <Freeze> or <Update>, or tap [ReCapture] on the touch screen to enter image acquisition status.
- Press the button to return to B mode.

5.11.2 Image Acquisition

To create an iScape image, start with an optimized 2D (color) image. The 2D image serves as the mid-line for the resulting iScape image.

1. Press the <Update> key or tap [Start Capture] on the touch screen to start the iScape image capture.
2. Scan slowly to obtain a single extended field of view image. You can also erase and retrace if the image is not satisfactory.
3. End image capture:

To end the image capture:

- Click [Stop Capture] on the touch screen, or,
- Press the <Update> key, or,
- Wait until the acquisition completes automatically.

After the acquisition is completed, the panoramic image will be displayed and the system enters iScape viewing mode.

Tip:

- During image acquisition, none of the parameters are adjustable, and functions such as measurement, comments and body marks are not available.
- ROI: a green box on the image indicating the boundary between the merged images and the unfinished images.
- Tip on the probe speed: During image slicing, the system gives feedback on the probe's moving speed in the form of colors and words. The meanings are as follows:

Status	ROI Color	Tip
Speed too low	Blue	Moving speed of the probe is too low.
Appropriate	Green	None.
Speed too high	Red	Moving speed of the probe is too high.

Guidance and precautions for even movement:

- Make sure there is enough coupling gel along the scan path.
- Always move the probe slowly and steadily.
- Continuous contact is required throughout the length of the extended image. Do not lift the probe from the skin's surface.
- Always keep the probe perpendicular to the skin's surface. Do not rock, rotate or tilt the probe during the scan.
- The system accommodates a reasonable range of motion velocity. Do not make abrupt changes in motion speed.
- Deeper scans generally require reduced acquisition speed.

5.11.3 iScape Viewing

After completing image acquisition, the system performs image splicing and then enters the iScape viewing mode.

In iScape viewing mode, you can perform the following functions:

- Setting image parameters. For details, see “5.11.3.1 Adjusting Image Parameters.”
- Image zooming. For details, see “5.11.3.2 Image Zooming.”
- Image rotation. For details, see “5.11.3.3 Rotating the Image.”
- Measurement, comments and body marks. For details, see “5.11.3.4 Measurement, Comments and Body Marks.”

5.11.3.1 Adjusting Image Parameters

In image viewing mode, you can adjust the following parameters:

- Image size
 - Tap [Actual Size] to display the image in its actual size.
 - Tap [Fit Size] to display the image in a size that fits the current window. This is the system's default format.
- Tint map
 - Press the knob under [Tint Map] to activate the function, then change the effect by rotating the knob.
- Ruler
 - Tap [Ruler] on the touch screen to hide or show the ruler around the image.
- Color Display (in Power iScape)
 - Tap [Color Disp] on the touch screen to display or hide the color image.
- Map (in Power iScape)
 - Rotate the knob under [Map] on the touch screen to select the map, as in Power mode.

5.11.3.2 Image Zooming

Press the <Zoom> button to zoom in/out on the panoramic image.

- Rotate the button clockwise to zoom in on the image.
- Rotate the button counter-clockwise to zoom out on the image.
- Roll the trackball to change the position of the magnified image.
- Press the <Zoom> key again to exit zoom mode.
- When the image displayed is bigger than the image area, the thumbnail is automatically displayed.

5.11.3.3 Rotating the Image

For the convenience of image viewing, you can rotate the image by rotating the knob under [Rotation] on the touch screen in increments of 5° .

5.11.3.4 Measurement, Comments and Body Marks

In iScape image viewing status, you can perform measurement, comments and body marks. The operations are the same as in B mode.

NOTE:

1. The measurement accuracy for spliced images may be degraded - exercise caution when measurements are performed on an iScape image.
2. If there is a trace during the retracing, do not perform measurement across the trace.

5.11.3.5 Evaluate Image Quality

Many variables may affect the overall image quality. It is important to evaluate the image content and quality before an image is used for diagnosis or measurements.

NOTE: iScape panoramic imaging is intended for use by well-trained ultrasound operators or physicians. The operator must recognize image items that will produce a sub-optimal or unreliable image.

The following items may produce a sub-optimal image. If the image quality does not meet the following criteria, you must delete the image and repeat image acquisition.

- The image must be continuous (no part of an image moves suddenly or disappears.)
- No shadow or absent signal along the scan plane.
- Clear profile of anatomy through the entire scan plane without distortion.
- Skin line is continuous.
- The images are captured from the same plane.
- There are no large black areas in the image.

5.11.4 Cine Review

Click [Review Cine] on the touch screen in panoramic image viewing status to enter cine reviewing mode. In cine reviewing mode, a green frame marker indicates the sequence of the currently reviewed images in the panoramic image on the left-hand side of screen. In cine review status:

- Roll the trackball to review the captured images frame by frame.
- Click [Auto Play] to start or end auto play.
- In auto play mode, tap [Auto Play] on the touch screen, or press/rotate the corresponding knob to change the play speed. When the speed is off, the system exits auto play mode.
- Review to a certain image. Press the knob under [Set Begin] to set the start point. Review to another image. Press the knob under [Set End] to set the end point. In auto play mode, the review region is confined to the set start point and end point.
- Click [Return] on the touch screen to exit cine review mode. The panoramic image displays.
- In cine review mode, press <Freeze> on the control panel to return to the acquisition preparation status.

5.12 Elastography

 **CAUTION:** Elastography images are provided for reference only, not for confirming diagnoses.

Elastography imaging is an option.

5.12.1 Basic Procedure for Elastography

1. Perform a B scan to locate the region.
2. Set the user-defined key for Elastography via the path: [Setup]→[System]→ [Key Config]. Press the user-defined key for Elastography on the control panel to enter the mode. Adjust the ROI according to the actual situation.
3. Select the probe according to the experience and actual situation.

4. Adjust the image parameters to obtain the optimized image and necessary information.
5. Adjust the ROI on the frozen image if necessary.
6. Save the image or review the image if necessary.
7. Perform measurement or add comments/body marks to the image if necessary.
8. Estimate the hardness of lesions according to the results.
9. Press to return to B mode.

5.12.2 Enter/Exit

■ Enter

Press the user-defined Elasto key on the control panel to enter the mode.

After entering the mode, the system displays two windows in real-time on the screen. The left one is the 2D image, and the right one is the Elasto image.

■ Exit

Press or the user-defined Elasto key on the control panel to exit and enter the mode.

5.12.3 Pressure Hint Curve

The screen displays the pressure curve in real time:



The X-axis represents time and the Y-axis represents pressure.

ROI Adjustment

Description To adjust the width and position of the ROI in Elasto imaging.

Operation When the ROI box is solid line, roll the trackball to change its position.

When the ROI box is a dotted line, roll the trackball to change the size.

Press <Set> to switch between the solid line and the dotted line status.

Smooth

Description To adjust the smooth feature of the Elasto image.

Operation To adjust the image smoothness. Adjust using the [Smooth] item on the touch screen.

The system provides 0-5 levels of smooth function: the bigger the value the stronger the effect.

Opacity

Description To adjust the opacity feature of the Elasto image.

Operation Rotate the knob under the [Opacity] item on the touch screen.

The system provides 0-5 levels of opacity function: the bigger the value the stronger the effect.

Invert

Description To invert the E color bar and therefore invert the colors of benign and malignant tissue.

Operation Tap [Invert] on the touch screen.

Single E

Description To switch between the B+E dual window and the single E window. E represents the Elastography image.

Operation Tap [Single E] on the touch screen. When the button is highlighted in green, the screen displays the single window E image.

Map

Description To select different maps for observation.

Operation Rotate the knob under the [Map] item on the touch screen to select the map.

The system provides E1-E6 maps, including 1 grayscale map and 5 color maps.

Tip: In Elasto imaging mode, image magnification is not available.

5.12.4 Cine Review

Press <Freeze> or open a elastography imaging cine file to enter cine review status.

5.13 Contrast Imaging

The contrast imaging is used in conjunction with ultrasound contrast agents to enhance imaging of blood flow and microcirculation. Injected contrast agents re-emit incident acoustic energy at a harmonic frequency much more efficient than the surrounding tissue. Blood containing the contrast agent stands out brightly against a dark background of normal tissue.

- Contrast imaging is an option.



Caution:

1. **Set MI index by instructions in the contrast agent accompanied manual.**
2. **Read contrast agent accompanied manual carefully before using contrast function.**

NOTE: Make sure to finish parameter setting before injecting the agent into the patient to avoid affecting image consistency. This is because the acting time of the agent is limited.

The applied contrast agency should be compliant with the relevant local regulations.

5.13.1 Basic Procedures for Contrast Imaging

To perform a successful contrast imaging, you should start with an optimized 2D image and have the target region in mind. To perform a contrast imaging:

1. Select an appropriate probe, and perform 2D imaging to obtain the target image, and then fix the probe.
2. Tap [Contrast] to enter the contrast imaging mode.
3. Adjust the acoustic power experientially to obtain a good image.
Tap [Dual Live] to be "On" to activate the dual live function. Observe the tissue image to find the target view.
4. Inject the contrast agent, and set [Timer 1] at "ON" to start the contrast timing. When the timer begins to work, the time will be displayed on the screen.
5. Observe the image, use the touch screen button of [Pro Capture] and [Retro Capture] or the user-defined key to save the images. Press <Freeze> to end the live capture.
Perform several live captures if there are more than one interested sections.
6. At the end of a contrast imaging, set [Timer 1] as "OFF" to exit the timing function. Perform procedures 3-5 if necessary.
For every single contrast imaging procedure, use [Timer 2] for timing.
If necessary, activate destruction function by tapping [Destruct] as "ON" to destruct the micro-bubbles left by the last contrast imaging; or to observe the reinfusion effect in a continuous agent injecting process.
7. Exit contrast imaging.
Press button to return to B mode.

5.13.1.1 Parameter Area Display

When entering contrast imaging mode, the screen displays the contrast image, and if [Dual Live] item on the touch screen is "ON", both the contrast image (marked with "C") and tissue image (marked with "T") are displayed (the two window position can be changed). Parameter area displays as follows:

Type	Parameter	Description
Contrast	FC	Contrast frequency.
	D	Depth.
	G	Gain.
	FR	Frame rate.
	DR	Dynamic Range.
	iTouch	iTouch status
Tissue	G	Gain
	DR	Dynamic Range.
	iTouch	iTouch status
Zoom	Z	Magnification factor

Type	Parameter	Description
Timing (If timer is "ON")	/	In real time mode, the time displayed is the elapsed time. In freeze mode, the timer stops working, the elapsed time is displayed.

5.13.1.2 Image Optimization

Parameters in Contrast mode are similar to those in B mode; please refer to B chapter for details, special Contrast imaging parameters are introduced in the following.

5.13.1.3 Timer

The two timers are used to record total time of contrast imaging and single time of one contrast exam.

After the image is frozen, Timer 1 is still timing, and after unfreezing the image, the corresponding time can be seen.

Timer 2 stops timing when one contrast exam is frozen, and after unfreezing the image, the Timer 2 is off.

NOTE: The starting time displayed may be inconsistent with the actual one due to system error or some other man-made mistakes; please check the agent-injecting time.

Set [Timer 1] as "ON" to start the timing at the moment you inject the contrast agent. Here, the screen displays the times at the lower corner.

- The time begins at 0.
- In live mode, there displays the elapsed time. For example, **00:00:08**, it means the elapsed time is 8s.
- Freeze the image during the timing, the timer stops working, and there displays the elapsed time. After unfreezing, the timer 1 continues working, and the timer 2 exits.
- Set [Timer 1] or [Timer 2] as "OFF", the timer discontinues its work.

5.13.1.4 Micro-bubble Destruction

Function: destruct the micro-bubbles left by the last contrast imaging; or to observe the reinfusion effect in a continuous agent injecting process.

- Entering: Tap [Destruct] on the touch screen to enable the micro-bubble destruction function.
- Parameters:
 - DestructAP: adjust the destruct acoustic power via the touch screen.
 - DestructTime: adjust the destruct time via the touch screen.

5.13.1.5 Dual Live

In live mode or freeze mode, set touch screen item [DualLive] as "ON" to enable dual live function. Both the contrast mode and tissue mode are displayed. The THI and B image are displayed on the screen if the [Dual Live] is enabled.

Tips:

- In dual live mode, the screen displays the contrast image and tissue image
- In freeze mode, there displays only one cine review progress bar as the contrast image and tissue image are reviewed synchronously.

- Image position

The contrast appears on the left of the screen if the contrast image position is enabled.

5.13.1.6 Mix Map

This function is to mix the contrast image with the tissue image, so that interested contrast regions can be located.

Tap [Mix] to select different mixing mode, and select different maps by knobs under [Gray Map]/[Tint Map] on the touch screen.

- When dual live function is on, you can see the mixed effect on the contrast image.
- When dual live function is off, you can see the mixed effect on the full screen image.

Select the map through the [Mix Map] item.

5.13.1.7 iTouch

On contrast status, you can also get a better image effect by using iTouch function.

- Press <iTouch> on the control panel to turn on the function.

The symbol of iTouch will be displayed in the image parameter area in the upper right corner of the screen once press <iTouch>.

Select different levels of iTouch effect through [iTouch] on the touch screen.

- Long press <iTouch> to exit the function.

5.13.1.8 Image Saving

- Live capture

In live mode, you can save the interested images by tapping [Pro Capture] and [Retro Capture].

- Cine saving

In live mode, press <Freeze> on the control panel to enter cine review status.

5.13.2 Measurement, Comment and Body Mark

The system supports image measurement, comment and body mark functions. For the details, please refer to the relevant sections.

6 Display & Cine Review

6.1 Image Display

6.1.1 Splitting Display

The system supports dual-split and quad-split display format. However, only one window is active at one time.

- Dual-split: press <Dual> key on the control panel to enter the dual-split mode, and using <Dual> key to switch between the two images; press on the control panel to exit.
- Quad-split: press user-defined <Quad> key on the control panel to enter the dual-split mode, and using user-defined <Quad> key to switch between the two images; press on the control panel to exit.

For the detailed display format, please refer to the content of each imaging mode chapter.

6.2 Image Magnification

The system supports three magnifications: spot, pan and iZoom, which can be realized by different operations through the related keys.

NOTE: Zooming an image changes the frame rate which tends to change thermal indices. The position of the focal zones may also change which may cause the peak intensity to occur at a different location in the acoustic field. As a result, the MI may change.

6.2.1 Spot

Procedures:

1. In image scanning mode, press<Zoom> to enter the sample volume definition status.
2. Define the sample volume: roll the trackball to change the box size and position, press <Set> to toggle between setting the size and position. And after sample volume is set, press <Zoom> again to enter spot zoom status.
Here, the sampled image is displayed, and meanwhile, image-in-image is displayed.
3. Rotate <Zoom> to adjust the magnification factor. The system provides a zoom range of 0.8-10. Roll the trackball to move the magnified image.
4. Exit: in spot zooming status, press <Zoom> again or press <Esc> to exit image magnification.

Tips:

- Spot zooming only can be realized on a scanning image.
- The size and position of sample volume box will be changed along with scanning depth and area.

6.2.2 Pan

Procedures:

1. Press <Zoom> knob to directly enter the pan zooming status. Image-in-image is displayed.
2. Rotate <Zoom> knob to change the magnification factor. The system provides a zoom range of 0.8-10.
3. Exit pan zooming: press <Zoom> knob.

6.2.3 iZoom (Full-screen Zooming)

- Function: to magnify the image in full screen.

According to the region to be zoomed, the system supports two types of full-screen zooming:

- The first type is to zoom in the standard area, including image area, parameter area, image banner, thumbnail area and so on.
- The second type is to zoom in the image area only.

- Manner:

- (1) Open the image (or the under scanning image), press the <F8 >iZoom key once to zoom in image in the way of the first type, and then press the key again to zoom in the image in the way of the second type.

- (2) Press <F8 > again to return to normal status.

6.3 Freeze/Unfreeze the Image

Press <Freeze> on the control panel to freeze a scanning image. In freeze mode, the probe stops transmitting acoustic power, and all images as well as the parameters are kept still.

Tip: after freezing an image, the system may enter cine review, measure, comment adding, or body mark mode, which is dependent upon preset. (Setting path: [Setup]→[System Preset]→[Image Preset]→ "Freeze Config")

Press <Freeze> in freeze mode to unfreeze the image, the system continues image scanning.

6.3.1 Imaging Mode Switching When Frozen

Imaging mode switching in freeze mode follows the following principles:

- In splitting display B mode, press to exit splitting display mode and display the image of the currently activated window in full screen.
- In freeze mode, the system supports imaging mode switching between the sub-modes (only for the activated window). For example, if the frozen image is of B+C+PW mode, then the system supports imaging mode switching between B+C+PW, B+C, B+PW and B by pressing <Color> or <PW>.
- The imaging mode and parameters of an unfrozen image is the same as the corresponding one that before frozen; but the display format is the same as the one before unfrozen.

6.3.2 Imaging Display Format Switching When Frozen

Image display format switching in freeze mode follows the following principles:

- 2D+M/PW (Press <Freeze> in 2D+M/PW scanning mode)
If the imaging mode before frozen is 2D (frozen) +M/PW (real time) or 2D (real time) +M/PW (frozen), then in freeze mode, you can switch between 2D (frozen) +PW (activated) or 2D (activated) +PW (frozen) by pressing <Update> key on the control panel.
- Dual/quad splitting display mode (Press <Freeze> key in dual/quad splitting display mode)
 - When enters freeze mode, the default activated window is the real-time window before frozen. Other image windows display the corresponding cine memories, if a certain cine memory is empty, then no image is displayed.
 - Press <Dual> or user defined Quad key to switch between dual-splitting and quad-splitting modes.
 - Press button on the control panel to enter the single display format, which displays the currently activated window. In single display format, press <Dual> or user defined Quad key to switch between dual-splitting and quad-splitting mode.
 - Unfrozen: in splitting display status, when you unfreeze the image you can only unfreeze the image in the activated window, other images still keep frozen. In single-window display status, the system displays single image after being unfrozen.

6.4 Cine Review

After you press <Freeze>, the system allows you to review and edit the images prior to the image frozen. This function is known as cine review. The magnified images can also be reviewed after <Freeze> is pressed, and the operating method is the same. You can perform post process operations, measurements, comments adding and body marks on the images being reviewed.

The system supports manual review as well as automatic review. The default mode is Manual Cine, but you can switch between Auto Cine and Manual Cine.

In addition, the system supports the images reviewed along with physiological waveforms, if the detection of physiological waveforms is performed.



CAUTION:

1. Cine Review images can be inadvertently combined in-between separate patient scans. The cine memory must be cleared at the end of the current patient and the onset of the next new patient by selecting the <End Exam> key on the control panel.
2. Cine files stored in the system's hard drive shall contain patient information, to avoid the selection of an incorrect image file and potential misdiagnosis.

6.4.1 Entering/ Exiting Cine Review

- To enter cine review:
 - Enter "[Setup]→ [System Preset]→ [Image Preset]" and set "Status after Freeze" to be "Cine". Press <Freeze> to freeze the image and enter the cine status, the <Cine> key indicator lights on automatically.
 - Open cine files in thumbnail, iStation or Review, the system enters automatic cine review status.
- To exit cine review:
 - Press <Freeze> key again, the system will return to image scanning and exit cine review.

6.4.2 Cine Review in 2D Mode

(B/B+Color/B+Power/B+TVI/B+TEI)

■ Manual cine review

After entering the cine review of 2D mode, rolling the trackball or rotating the multifunctional knob will display the cine images on the screen one by one.

If you roll the trackball to the left, the review sequence is reversed to the image-storing sequence, thus the images are displayed in descending order. Whereas, if you roll the trackball to the right, the review sequence is the same as the image-storing sequence, thus the images are displayed in ascending order. When the reviewing image reaches the first or the last frame, further rolling the trackball will display the last or first frame.

The cine progress bar at the bottom of the screen (as shown in the figure below):

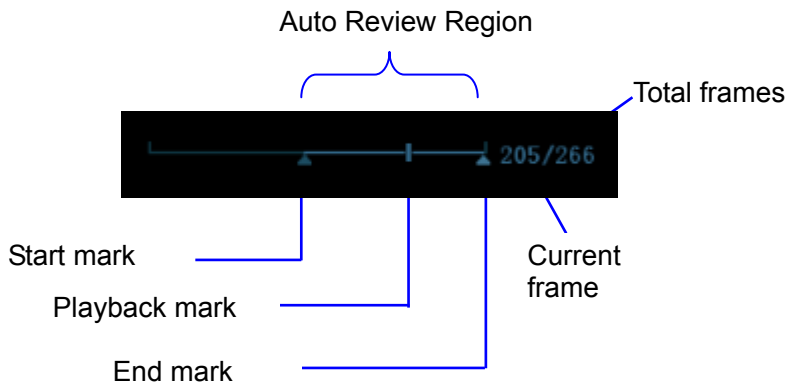

■ Auto Review

- Reviewing all
 - a) In the manual cine review status, click [Auto Play] in the soft menu to activate auto cine review.
 - b) Reviewing speed: In the auto cine review status, click [Auto Play] in the soft menu to adjust the review speed.
 - c) In auto review status, Click [Auto Play], or roll the trackball to enter manual review.
- Setting Region of Auto Review

You can set a segment of cine loop which can be reviewed automatically. After the auto review region is set, the auto cine review can only be performed within

this region; but the manual cine review can be performed beyond this region. When the cine file is saved, only the images within this region are saved.

- a) Set first frame: Manually review the images until the frame which you want to set it as start point, and then click [Set First Frame] to set it as the start point.
- b) Set end frame: Manually review the images until the frame which you want to set it as end point, and then click [Set End Frame] to set it as the end point.
- c) Click [Auto Play] again or roll the trackball to enter manual review status; or press <Cine> to exit cine reviewing.
- d) Click [Skip to First]/ [Skip to Last] to review the first or last image.
- e) Click [Save Cine] in the soft menu to save the cine images of the set region.

Tips: you can perform cine review on each image window in the dual/ quad splitting mode.

You can also press <Menu> to see the menu, and use the corresponding items to do the above settings.

6.4.3 Cine Review in M or D Mode

Enter cine review in M or D mode, and then roll the trackball or rotating the multifunctional knob, the cine images are displayed on the screen one by one.

Roll the trackball to the left, the review progress slider moves to the left, the images moves to the right, and the earlier stored images are invoked. Whereas roll the trackball to the right, the review progress slider moves to the right, and the images move to the left, the recently stored images are invoked. When you review the images until the earliest or the latest frame, further rolling the trackball will display the last or first frame.

The cine progress bar at the bottom of the screen (as shown in the figure below):

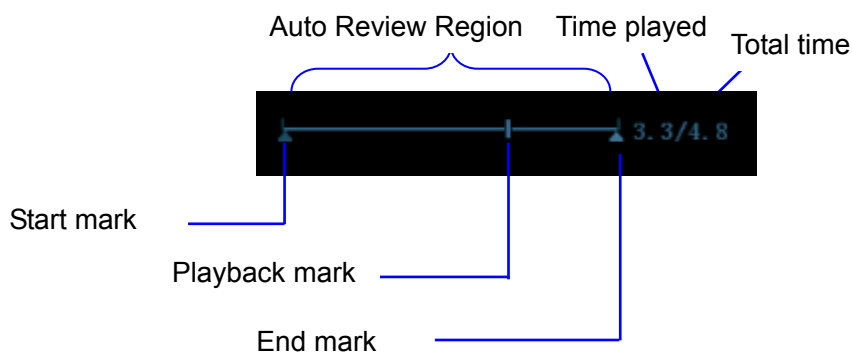

Cine review operations are the same as those of 2D mode.

6.4.4 Linked Cine Review

The linked cine review refers to review of the images captured at the same moment.

- Dual live mode(B+C)
- B+M
- PW+B duplex mode
- PW+C+B triplex mode

The frame mark  on the time mark of M/PW image indicates the corresponding 2D image. In the statuses rather than the dual live, you can only review images in the currently active window.

6.5 Image Compare

6.5.1 Cine Compare

1. Press <Review> to enter Review screen, press <Ctrl>+<Set> to select files to be compared.
Tip: for B/B+COLOR/B+TVI/B+POWER/B+TEI mode image, you can select at most 4 images; for PW/M/CW/TVD mode image, you can select at most 2 images.
2. Click [Compare] to enter image compare mode.
3. Review the images of different image windows (cine replaying can't be performed for single-frame image file), press <Dual> key or <Quad> key to switch the active image window.

The window with the highlighted "M" mark is the current activated window.

Press <Cursor> and double click the image in the thumbnail area on the right side of the screen to change the current active window

4. Save the image if it is necessary.
5. Click [Return] on the screen or press <Freeze> to exit image compare.
Image compare of different exams for the same patient:
 - (1) Select different exams in iStation screen, select [Review] in the popped up menu to enter Review screen.
 - (2) In Review screen, click [History] to select the exam; click to select the image to be compared in different exams, and click [Image Compare].

6.5.2 Frame Compare

1. Freeze the image in B/C mode, tap [Frame Compare] to enter the windows of different frames. Besides, you can double click the cine file in the thumbnail area to go for same cine different images compare.
The two windows display the same image when initially enter into image compare.
2. Roll the trackball or rotate the multifunctional knob to review the images; switch the window by pressing <Update>.
3. Adjust the image parameters or do other operations (like image zoom in/zoom out, image saving, comment) if necessary.
4. Click [Frame Compare] again to return to freeze mode; press <Freeze> or click [Return] to go to image scanning.

Tips: image compare only can be performed on single-format B/C mode images only.

6.6 Cine Saving

■ Live capture

Live capture refers to saving the images or cines in image scanning status; after the storage, the system continues image scanning.

Live capture can be divided into 2 kinds: retrospective and prospective.

- Retrospective saving is to save the specified images before the current moment; to save the images stored in the cine memory to the system hard disk.
- Prospective saving is to save the specified images later than the current moment; to save the images to both the cine memory and the system hard disk.

The live capture time can be set.

To perform live capture:

- In scanning mode, press the <Save> key on the control panel (The key has already been assigned the function as “Save Clip (Prospective) to hard disk” or “Save Clip (Retrospective) to hard disk”).

Tips:

- In retrospective saving, if any parameter is modified during saving, the changes will not be saved to the cine. While in prospective saving, any parameter modification before the saving finished can be saved into the cine.
- Press the save key again or <Freeze> to stop saving.
- When a saving is completed, a thumbnail is showed in the Thumbnail area.
- Frozen image storage

In frozen mode, press the <Save> key on the control panel (The key has already been assigned the function as “Save Clip (Retrospective) to hard disk”).

After the cine is successfully saved, there is a thumbnail displayed on the screen.

The live capture time can be set.

6.7 Cine Memory

6.7.1 Cine Memory Setting

There are 2 ways of cine memory split: auto and split.

Setting path: select "Auto" or "Split" for cine memory in [Setup]→ [System Preset]→[Image Preset]. Where,

- "Auto" for the cine memory indicates the system splits the cine memory as per the number of B image windows.
- “Split” indicates the system always splits the cine memory, even if in the single-B window, the system splits the cine memory into two as well. You can press key to switch and display the images in either memory, so you can compare images in Split mode.

The memory capacity is evenly distributed as per splitting number, as shown in the following table (Taking B images in low density as an example, the capacity of B cine memory is N frames):

Imaging Mode \ Split	Single-B/ Color	Dual	Quad
Auto	One memory, with capacity N frames.	The memory splits into two, with capacity N/2 frames each	The memory splits into four, with capacity N/4 frames each
Split	The memory splits into two, with capacity N/2 frames each	The memory splits into two, with capacity N/2 frames each	The memory splits into four, with capacity N/4 frames each

6.8 Cine Settings

You can set the cine length via “[Setup]→[System Preset]→[General]”. The items are shown as follows:

- Non-live storage (the items are shown as follows)

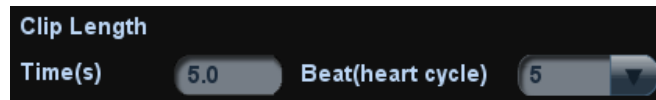

- For Time without ECG(s), 1~60s.
- For Time (with ECG Loop): the unit is Beat, 1~16.
- Live capture (the setting items are shown as follows)
 - Type: Retrospective, Prospective.
 - Cine length:



7 ECG

The system can be configured with the optional physio module. In that case, the ECG signal is displayed on the image, and can be reviewed simultaneously with the image.

- When the system is connected with the ECG module:
 - The Physio menu is available.
 - The ECG icon including heart-shaped symbol and heart rate symbol are displayed on the screen.
- The system supports ECG signal from ECG lead or external ECG signal devices.
 - Use DC-IN to connect to the external ECG signal devices.

 WARNING:	<ol style="list-style-type: none">1. DO NOT use the physiological traces for diagnosis and monitoring.2. To avoid electric shock, the following checks shall be performed prior to an operation: The ECG electrode cable shall not be cracked, frayed or show any signs of damage or strain. The ECG electrode cable shall be correctly connected. You should use the ECG leads provided with the ECG module. Otherwise it may result in electric shock.3. The ECG electrode cable must be connected to the system first. Only after the cable is connected to the system, can the patient be connected to the ECG electrodes. Failure to follow these instructions may subject the patient to electric shock.4. DO NOT place the ECG electrodes directly in contact the patient's heart; otherwise it may lead to stop of the patient's heartbeat.5. DO NOT apply the ECG electrodes if the voltage exceeds 15 volts. This could produce an electric shock.6. Before using high frequency electric surgical unit, high frequency therapeutic equipment or defibrillator, be sure to remove the ECG electrode from the patient, in order to prevent electric shock.7. Conductive parts of electrodes and associated connectors for ECG should not contact other conductive parts including earth/grounding.8. Frequent trampling or squeezing on the cables may result in cable break-down or fracture.
---	---

<p>NOTE: When abnormality is detected, please check if ECG leads are properly connected with the system.</p>

7.1 ECG Operation Basic Procedures

1. Connect the ECG device.
 - Turn off the power supply of the system, and connect the ECG cable to the port in the system (For connection, please refer to “2.9 Physiological-signal Panel”)
 - Turn on the power supply of the system
 - Place the ECG electrodes on the patient’s body (as shown in the following figure)

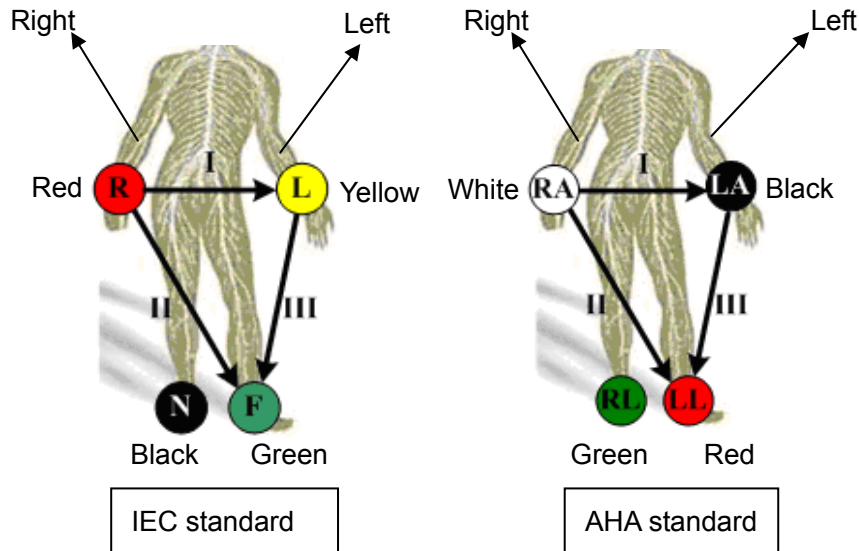

2. Press ECG user-defined key (set in “[Setup] → [System Preset] →[Key Config]”) to enter physio operation status.
3. Select [ECG] to be “On”, and the heart-shaped symbol appears on the upper right part of the screen.
4. Switch the imaging modes and display formats, and adjust relevant parameters to optimize the image.
5. Parameter adjustment:
On the Physio page, you can adjust [Speed], [ECG Gain], [ECG Pos].
6. Freeze the images and review them. For details, please refer to “7.3 ECG Review”
7. Exit ECG mode, and remove ECG electrodes from the patient.
In ECG mode, set [ECG] to be “Off”, the ECG waveform disappears and the system exits ECG mode.

7.2 Parameter Description

Parameter	Description
ECG	Function: to control the display of ECG trace in live status. Value: On/Off, On is to display the trace, while Off is to hide the trace. In scanning mode, turn off ECG display will stop ECG signal acquisition. In freeze mode, this is used to show or hide the ECG trace.
ECG Source	Select ECG source.
ECG Gain	Function: to set the amplitude of ECG trace. Method: click [Gain] in the soft menu or menu. Value: 0-30, in increments of 1.
ECG Position	Function: to set the vertical position of the ECG trace on the image display. Method: click [ECG Pos] in the soft menu or menu. Value: 0%-100%, in increments of 5%.
Speed	Function: change the speed of the physio trace. Value: 1-6 The refresh speed of the physio signal on B image is independent from the refresh speed of timeline refresh speed (M mode, PW and CW mode)

7.3 ECG Review

When an image is frozen, the ECG waveform will be frozen at the same time. When images are reviewed with the ECG electrodes connected, the ECG waveform is the reference for time.

After the images are frozen, all real time images are in the status of linked review.

The frame position marker indicates the time relationship between the currently reviewed 2D image and the ECG trace or M/D image.

8 Measurement

You can perform measurements on a zoomed image, cine reviewing image, real-time image, or frozen image. For measurements details, please refer to the [Advanced Volume].

-  **WARNING:**
1. Be sure to measure areas of interest from the most optimal image plane to avoid misdiagnosis from inaccurate measurement values.
 2. To obtain accurate Doppler flow measurement values, make sure the transmitting beam is not perpendicular to the flow, otherwise false readings and potential misdiagnosis may result.

-  **CAUTION:**
1. If an image is unfrozen or the mode is changed during a measurement, the calipers and measurement data will be cleared from the screen. The general measurement data will be lost (the application measurement data are stored in the report).
 2. If the system is turned off or <End Exam> is pressed during a measurement, the data not saved will be lost.
 3. In Dual-B imaging mode, the measurement results of the merged image may be inaccurate. Therefore, the results are provided for reference only, not for confirming a diagnosis.

8.1 Basic Operations

- To enter/ exit measurement
Press <Caliper> to enter general measurement.
Press <Measure> key to enter application measurement.
Press <Caliper> or <Measure> again or <Esc> to exit.
- Measurement result and help information
The system displays and updates measurement results in the result window.
The help information concerning measurement and calculation is displayed in the Help Information area at the bottom of the screen.

8.2 General Measurements

8.2.1 2D General Measurements

2D general measurements refer to general measurements on images of B, Color, Power or iScale imaging modes. The measurements listed below can be performed:

Measurement Tools	Function
Distance	Measures the distance between two points of interest.
Depth	The distance between probe surface and the probing point along ultrasound beam.
Angle	The angle between two intersected planes.
Area	Measures the area and perimeter of a closed region.
Volume	The volume of a target.
Cross	The length of two line segments, which are perpendicular to each other.
Parallel	The distance between each pair of parallel lines in a sequence.
Trace Length	Measures the length of a curve on the image.
Double Dist	Measures the length of two line segments, which are perpendicular to each other.
Distance Ratio	Measures the lengths of any two line segments and the calculated ratio.
Area Ratio	The areas of any two regions and the calculated ratio.
B histogram	The grayscale distribution of ultrasonic echo signals in a closed region.
B profile	The grayscale distribution of ultrasonic echo signals across a line.
Color Velocity	Color flow velocity (only valid for Color mode).
Volume Flow	Blood flow through some vascular cross section per unit time.
IMT	Measures the distance between LI (Lumen-Intima) and MA (Media-Adventia).
Volume	Measures the volume of the target object.

8.2.2 M General Measurements

M general measurements refer to general measurements on M mode, Color M mode, Free Xros M mode images. The measurements listed below can be performed:

Measurement Tools	Function
Distance	The vertical distance between two points.
Time	The time interval between any two points.
Slope	Measures the distance and time between two points and calculates the slope.
HR	Measures the time of n (n≤8) cardiac cycles and calculates the heart rate in M mode image.
Velocity	Calculates the average velocity by measuring the distance and time between two points.

8.2.3 Doppler General Measurements

Doppler general measurements refer to general measurements on PW/CW mode images. The measurements listed below can be performed:

Measurement Tools	Function
Time	The time interval between any two points.
HR	N intervals (n≤8) are measured to calculate a PW mode derived HR value in Beats Per Minute (BPM).
D Velocity	On the Doppler mode image, measure velocity, PG (pressure gradient) and spectrum correction angle of a point on the Doppler spectrum waveform and etc.
Acceleration	Measure the velocities of two points and their time interval on the Doppler image, and calculates the acceleration, pressure gradient, velocity difference and correction angle.
D Trace	On the PW mode image, one or several Doppler waveforms are traced to obtain speed and PG, etc.
PS/ED	Measure the Peak Systolic (PS) velocity and End Diastolic (ED) velocity on the Doppler spectrum, and calculates resistance index (RI), S/D and correction angle.
Vas Area	Measures the area of the vascular section of the blood flow.

8.3 Application Measurement

The system can be configured with the following application measurement packages corresponding to the application packages:

- Abdomen measurements - Used for measurements of abdominal organs (liver, gall bladder, pancreas and kidney, etc.) and large abdominal vessels.
- OB measurements - Used for measurements of fetal growth indexes (including EFW) as well as GA and EDD calculations. The fetus can be evaluated through growth graph analysis and fetal biophysical profile.
- Cardiac measurements – Used for left ventricle function measurements and measurements of main artery and vein parameters, etc.
- Gynecology measurements - Used for the uterus, ovary and follicles, etc.
- Small Part measurements – Used for small parts such as thyroid.
- Urology measurements - Used for prostate, seminal vesicle, renal, adrenal, micturated and testicle volume.
- Orthopedics measurements – Used for hip joint measurement.
- Vascular measurements – Used for carotid, cerebral, upper and lower extremities vessels, etc.
- EM measurements – Used for EM related full functional measurement.

8.4 Measurement Accuracy

Table 1 Error of 2D Images

Parameter	Value Range	Error
Distance	Full screen	Within $\pm 2\%$
Area	Full screen	Within $\pm 6\%$
Circ	Full screen	Within $\pm 7\%$
Angle	Full screen	Within $\pm 3\%$.
Volume	Full screen	Within $\pm 7\%$

Table 2 iScape Measurements

Parameter	Probe Type	Error
Distance	Full screen	Within $\pm 5\%$ (L14-6NE, L12-3E, P4-2, D7-2E, 3C5A, 7L4A probe)
	Full screen	Within $\pm 10\%$ (V11-3, CB10-4E probe)

Table 3 Time/Motion Measurements

Parameter	Value Range	Error
Distance	Full screen	Within $\pm 3\%$
Time	Timeline Display	Within $\pm 2\%$
Heart rate	Timeline Display	Within $\pm 3\%$
Velocity (PW mode)	10-200cm/s: (for L14-6NE, L12-3E, CB10-4E, 7L4A) 10-300cm/s: (for P4-2, D7-2E, V11-3, 3C5A)	When angle $\leq 60^\circ$, $\leq 5\%$.

Parameter	Value Range	Error
Velocity (CW mode)	10-300cm/s (for P4-2)	When angle $\leq 60^\circ$, $\leq 5\%$. (not including pencil probe)

Table 4 Doppler Velocity Measurements

Parameter	Value Range
Velocity (PW mode)	Min. ≤ 0.10 cm/s, Max. ≥ 462 cm/s
Velocity (CW mode)	Min. ≤ 0.06 cm/s, Max. ≥ 3080 m/s
Velocity (Color mode)	Min. ≤ 1 cm/s, Max. ≥ 239.5 cm/s

NOTE: Within the selected field range, the measurement accuracy is ensured within the range mentioned above. The accuracy specifications are performance in the worst conditions, or based on the real test for the system, regardless of acoustic speed error.

9 Comments and Body Marks

9.1 Comments (Annotations)

Comments can be added to an ultrasound image to bring attention, notate or communicate information observed during the examination. You can add comments to: zoomed image, cine review image, real-time image, frozen image. You can type the character as comments; insert the pre-defined comments from the comment library; or insert arrow markers.

 **WARNING:** You must ensure that the entered comments are correct. Incorrect comments may cause misdiagnosis!

9.1.1 Comments Basic Procedures

1. To enter comment status:
 - Press the <Text> key, and the cursor becomes “|”.
 - Press any alphanumeric key, and the corresponding letter or numeral is displayed besides the cursor.
 - Press the <F12> (Arrow) key to enter the arrow-adding status.

Tips: when the system entered comment status, the default characters entered are uppercase. You can see the <Caps Lock> indicator lights on.
2. Place the cursor to the desired place to set the comment location. Add new comment to the image according to actual situation. Here, you can modify, move, delete, hide or display the completed comments.
3. To exit comment status:
 - In the comment status, press <Text> key.
 - Or press <Esc> or other operating mode keys, such as <Measure> key.
 - In the arrow-adding status, press the <F12> (Arrow) key.

9.1.2 Touch Screen Display in Comments

The system can be configured with comment text libraries including Abdomen, Cardiology, GYN (Gynecology), OB (Obstetrics), Urology, SMP (Small Part), Vascular, PED (Pediatric), Nerve Blocks and emergency medicine. In comments status, you can enter the comment text using the screen menu or touch screen.

- To set the comment home location.
Roll the trackball to move the cursor to the desired comment location and tap [Set Home] on the touch screen.
- Return the cursor to the set home location.
Press <Home> on the control panel or tap [Home] on the touch screen to return the cursor to the set home location.
- Navigate through the comment libraries
To select the comment library, rotate/press the knob under the [Library] button on the touch screen.
- Add/modify comment positions
Tap [RT/LT], [Sag/XS] or [Prox/Mid/Distal] to directly mark the position. Move the cursor onto the comment item to be modified, tap [RT/LT], [Sag/XS] or [Prox/Mid/Distal] to change the already-added comment position.
- Change Font Size/Arrow Size
To change the font size of comment text, rotate the knob under the [Font Size] button on the touch screen to select from Small, Medium and Large.
To change the arrow size, rotate the knob under the [Arrow Size] button on the touch screen to select from Small, Medium and Large.
- Comment display/hide
Tap [Hide]/[Display] on the touch screen to display or hide the comments.
- Page-turning
If there is more than one page of comment text for the current exam mode, you can navigate to other pages by swiping the touch screen leftwards/rightwards.
- User-defined comments
You can customize comments if necessary, including adding/deleting comments and adjusting the comment display on the touch screen menu.

■ Tracing

- (1) In comment status, tap [Trace] on the touch screen to activate the trace function. The current image is also displayed on the touch screen.
- (2) Control Panel operation:
 - a) Roll the trackball to the desired position and press <Set> to confirm the start point.
 - b) Roll the trackball to move the cursor along the edge of the desired region and trace the outline of the region.
 - Rotate the <Angle> knob counter-clockwise to cancel 1 pixel of trace.
 - Rotate the <Angle> knob clockwise to restore 1 pixel of trace.
 - Short press <Clear> to clear last trace. Long press <Clear> to delete all tracing.
 - c) Press <Set> to finish tracing.

Touch screen operation:

- a) Trace around the ROI by touching the touch screen image with your finger.
- b) Remove your finger to finish tracing.
 - [Clear]: touch to delete traces in reverse order one by one.
 - [Clear All]: touch to delete all traces.
- c) Click [Exit] to exit tracing.

9.1.3 Adding Comments

The system can be configured with comment text libraries including Abdomen, Cardiology, GYN (Gynecology), OB (Obstetrics), Urology, SMP (Small Part), Vascular, PED (Pediatric) Nerve Blocks and EM (Emergency).

■ Typing comment characters

- (1) To set the comment location:

Roll the trackball or press directional keys on the control panel to move the cursor to the desired location for comments.
- (2) To type the alphanumeric characters:
 - Type the alphanumeric characters through the qwerty (The default characters are uppercase).
 - To type the upper characters, press <Shift> on the control panel and the character key at the same time.
- (3) Move to a new line:

In the edit status (the characters are in green color), press <Enter> to move the cursor to the new line, and the location of the cursor is aligned with that of the first line.
- (4) In the edit status, move the trackball or press the multifunctional knob to confirm the character added, and the color of the character added turns yellow.

■ Adding a comment text

Move the cursor onto the desired comment text in the menu and press <Set> or the multifunctional knob, and then the system adds the selected comment text on the set location. The added comment text is in the edit status, so you can edit the comment text added.

- Add combined comment
 - a) Press <Menu> or the multifunctional knob to show the menu.

- b) Rotate the multifunctional knob to view the comments one by one
- c) Press the knob again to add the selected item onto the image (comment added in an editable state)
- d) Rotate the multifunctional knob to search for the next part, and press the knob again to add the second part of the combined comment.
- e) Repeat procedures to add other parts of a combined comment.
- f) Press <Set> to complete the comment.

■ Adding an arrow

You can add an arrow to a location where you want to pay attention.

- (1) Press <F12> (Arrow) key, and an arrow will appear at the default position.
- (2) Adjust the arrow
 - Adjust the position and orientation of the arrow: roll the trackball to the desired position and use the multifunctional knob to change the orientation in 15° increments.
 - Click the [Arrow Size] item on the soft menu to change the arrow size.
- (3) Press <Set> or <Enter> to anchor the arrow position, and then the arrow turns yellow.
- (4) Repeat the above steps to add more arrows if necessary.
- (5) Press <F12> (Arrow) key, <Esc> or to exit the arrow comment status.

■ Tracing

- (3) In comment status, tap [Trace] on the touch screen to activate the trace function. The current image is also displayed on the touch screen.
- (4) Control Panel operation:
 - d) Roll the trackball to the desired position and press <Set> to confirm the start point.
 - e) Roll the trackball to move the cursor along the edge of the desired region and trace the outline of the region.
 - Rotate the <Angle> knob counter-clockwise to cancel 1 pixel of trace.
 - Rotate the <Angle> knob clockwise to restore 1 pixel of trace.
 - Short press <Clear> to clear last trace. Long press <Clear> to delete all tracing.
 - f) Press <Set> to finish tracing.

Touch screen operation:

- d) Trace around the ROI by touching the touch screen image with your finger.
- e) Remove your finger to finish tracing.
 - [Clear]: touch to delete traces in reverse order one by one.
 - [Clear All]: touch to delete all traces.
- f) Click [Exit] to exit tracing.

9.1.4 Moving Comments

1. Move the cursor onto the comment that needs to be moved. Press <Set> to select it, and a highlighted box appears around the comment.
2. Roll the trackball to move the comment to the new position.
3. Press the <Set> key to anchor the comment in the new position, and the comment-moving operation is complete.

9.1.5 Modifying (Editing) Comments

■ Modifying (Editing) characters

1. In comment status, move the cursor over the comments to be modified.
 - Press the alphabetic keys to enter the character at the cursor position.
 - Or, double press <Set> to enter comment editing status and use the direction keys to move the cursor to the desired location to insert/delete characters. Either type characters by pressing the corresponding keys or select the new comment text from the menu.
2. Press <Del.> to delete the comment character or text on the right side of the cursor. Press <Backspace> to delete the comment character or text on the left side of the cursor.
3. Roll the trackball or press <Set> to confirm the modification and exit the edit status. The comment turns to yellow.

If there are already comments on the screen, press the space bar to enter editing status.

■ Modifying (Editing) Arrows

1. Move the cursor over the arrow that needs to be modified. After the cursor turns to , press the <Set> key. The current arrow turns green, and there is a green frame around the arrow indicating that the arrow can be edited. Move the cursor to change the arrow's position.
2. Rotate the <Angle> knob to modify the arrow's direction.
3. Press the <Set> or <Enter> key to complete the operation.

9.1.6 Deleting Comments

■ Deleting comment characters, texts or arrows

- (1) Move the cursor to the comment to be deleted.
- (2) Press the <Set> key to select the comment.
- (3) Press the key to delete the selected comment.

Or,

- (1) Move the cursor to the comment to be deleted.
- (2) Press <Clear> to delete the selected comment.

■ Deleting a recently-added character, text or arrow

If no comment is selected, press <Back> to delete the recently-added comment.

■ Delete all comments (characters, texts or arrows)

Press the <Clear> key to delete all comments.

- | |
|---|
| <p>NOTE: 1. When no object is selected, pressing the <Clear> key will clear all comments and all measurements calipers.</p> <p>2. After powering off, the system will clear all comments on the image.</p> |
|---|

9.1.7 Comment Setting

■ Comment Setting

Enter the “[Setup]→ [System]→ [Application]” screen to perform the following setting:

- You can preset whether to clear the comments when unfreezing the image or changing the probe/exam.
- Set whether body marks are erased when the image is unfrozen.

9.2 Body Marks

The Body Mark feature is used for indicating the exam position of the patient as well as probe position and orientation. The system can be configured with body mark libraries including Abdomen, Cardiology, GYN (Gynecology), OB (Obstetrics), Urology, SMP (Small Part), Vascular, EM (Emergency) and Nerve. In addition, the system supports to import user-defined body marks.

9.2.1 Touch Screen Display in Body Mark

The body mark touch screen displays the settings for the current mode:

■ Library

Rotate the knob under the [Library] button on the touch screen or press the knob to switch to the body mark library. Corresponding body marks are shown on the left.

■ Page-turning

If there is more than one page of body marks, rotate the knob under [Page] to turn the pages.

■ User-defined body mark

Tap [Custom] to enter the dialog. You can import body mark graphs here.

You can import a user-defined body mark in BMP/PNG format of 120*120 (unit: pixel) in size.

■ Save Probe

If the probe mark direction and position is determined for the current body mark being added, tap [Save Probe] to save the current probe mark direction and position for the body mark.

9.2.2 Adding Body Marks

1. Enter Body Mark status. Use the knob under [Library] to select the body mark category.
2. Adding Body Marks:
 - Adding body marks using the trackball and <Set> key.
Move the cursor over the desired body mark to highlight your choice. Press <Set> to add the body mark.
 - Adding body marks using the touch screen.
Touch the desired body mark on the touch screen directly.
3. To adjust the probe position and orientation marker:
 - Roll the trackball to position the probe marker.

- Rotate the <Angle/Steer> knob to adjust the orientation.
 - Tap [Save Probe] to save the current probe mark direction and position for the body mark.
4. Press <Set> to confirm the position and orientation of the probe marker and exit body mark mode.

9.2.3 Moving Body Marks

You can move the body mark graphics to any desired position within the image area.

1. Roll the trackball to move the cursor onto the body mark. The cursor changes into , indicating you can move the pictogram to a new position.
2. Press <Set> key to select the body mark, and a frame will appear around the graphics.
3. Roll the trackball to move the body mark to the desired position.
4. Press <Set> to anchor and confirm the new graphics position.

NOTE: In Dual B Mode, a body mark cannot be moved between the separated image windows.

9.2.4 Deleting Body Marks

- To delete a body mark
 - (1) Use the trackball to position the cursor on the body mark graphic and Press <Set> to select.
 - (2) Press <Clear> to delete the selected body mark.

NOTE: In the Body Mark mode, if no object is selected, pressing the [Clear] key will clear all comments, body marks and general measurements from the screen.

Tips:

- Powering off, preset returning, switching the exam/ patient/ mode/ probe will clear the body marks.

10 Patient Data Management

An exam record consists of all information and data of one exam.

An exam record consists of the following information:

- Patient basic information and exam data
- Image files
- Reports

NOTE:

1. DO NOT use the internal hard drive for long-term image storage. Daily backup is recommended. External storage media is recommended for image archive.
2. The system patient database space is limited, please back up or clear patient data in time.
3. Mindray is not responsible for lost data if you DO NOT follow suggested backup procedures.

10.1 Patient Information Management

10.1.1 Enter Patient Information

The general patient information and exam information are entered through the Patient Info screen, for details; please refer to “4.2.1 New Patient Information”

After completion of patient information entry, click [OK] to save the patient information to the patient data.

10.1.2 Patient Information Setting

Open “[Setup]→[System Preset]→[General]”, and then set the following in the Patient Info area. Here, you can select if to display patient gender, age or operator in the screen; set the H&W applied unit and select the using surface formula.

- Image banner patient information displaying
- H&W Unit
- Surface formula setting

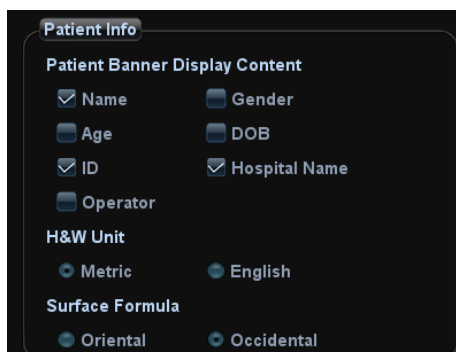

10.2 Image File Management

You can store the image files either in the patient database in the system, or to external memory devices. For a saved image, you can perform operations like image reviewing, analyzing and demonstration (iVision).

10.2.1 Memory Media

System supported memory media including:

- System hard disk
- USB memory devices: USB flash drive, removable USB hard disk
- CD-R/RW, DVD±RW

10.2.2 Image File Formats

The system supports two types of image file formats: system-relevant and PC-compatible.

■ System-relevant formats:

- Single-frame image file (FRM)
Refers to single-frame static image files not to be compressed; you can perform measurements and comments adding on this type of files.
- Cine file (CIN)
System-defined multi-frame file format; you can perform manual or auto cine review, and perform measurements or add comments for the reviewed images. After you open a stored CIN file, the system automatically enters cine review status.

The system can save FRM files as BMP, JPG, TIFF or DCM files, or save CIN files as AVI, DCM files.

■ PC-compatible formats:

- Screen file (BMP)
Single-frame file format, used to save the current screen, non-compressed format.
- Screen file (JPG)
Single-frame file format, used to save the current screen in the compressed format; you can set the compression ratio.
- TIFF: Single-frame export format
- Multi-medium files (AVI)
Multi-frame file format, general cine file format.
- DICOM files (DCM)
DICOM standard files format, single-frame or multi-frame format, used to record patient information and images.

10.2.3 Image Storage Preset

■ Set image size

You can set the image size via “[Setup]→[System Preset]→[General]”. The items are shown as follows:

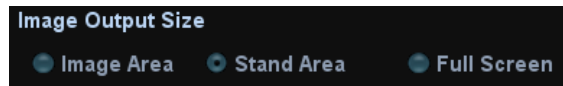

■ Set cine saving length

For details, please refer to “6.4 Cine Review”.

■ Storage image/clip linked operation

You can set to send image/clip to other media when you save/clip to hard disk (10.2.4 Quickly Saving Images to the System), the setting path is: [Setup]→ [System Preset]→[General]→ “Image/clip storage”

- Image can be sent to: local default printer, DICOM storage, DICOM printer.
- Clip can be sent to DICOM storage.

10.2.4 Quickly Saving Images to the System

■ To save a single-frame image to the system quickly:

(1) Set the user-defined key through the path: [Setup]→[System Preset]→[Key Config]. Select a key in the Key Function field on the left side and select “Save Image to hard drive” in the Output page of Function field on the right side.

(2) Press the user-defined key to save the image.

- In the image screen, press the user-defined key to save the current single-frame image, and the image is saved with the default filename in the default file directory in the FRM format. The thumbnail of the image will appear in the thumbnail area on the right side of the screen. When you move the cursor onto the thumbnail, its filename with suffix will be displayed.
- When a dialog box is displayed on the current screen, press the user-defined key to save the screen in the BMP format.

■ To save cineloop image to the system quickly:

(1) Set the user-defined key through the path: [Setup]→[System Preset]→[Key Config]. Select a key in the Key Function field on the left side and select “Save Clip (Retrospective) to hard drive” or “Save Clip (Prospective) to hard drive” in the Output page of Function field on the right side.

(2) Press the user-defined key to save the image.

Press the user-defined key to save the cine file in the default file directory in the CIN format.

The thumbnail of the image will appear in the thumbnail area on the right side of the screen. When you move the cursor onto the thumbnail, its filename with suffix will be displayed.



You can set clip saving length in the path: [Setup]→[System Preset]→[General].

10.2.5 Quickly Saving Full Screen Image to the System

1. Set the user-defined key through the path: [Setup]→[System Preset]→[Key Config]. Select a key in the Key Function field on the left side and select “Save Full Screen Image to hard drive” in the Output page of Function field on the right side.
2. Press the user-defined key to save the image.
 - In the image screen, press the user-defined shortcut key to save the current screen image, and the image is saved with the default filename in the default file directory in the FRM format. The thumbnail of the image will appear in the thumbnail area on the right side of the screen. When you move the cursor onto the thumbnail, its filename with suffix will be displayed.

10.2.6 Thumbnails

The stored images or cineloops are displayed in the form of thumbnails on the screen:

- In the iStation screen, the thumbnails refer to the images stored for the selected exam or the selected patient.
- In the scanning or freeze mode, the thumbnails refer to the images stored in the current exam. You can click  or  to page down or up the thumbnails when there are more than one page.
- In the Review screen, the thumbnails refer to the images stored in the same exam.
- In the Review screen, open an image to enter the image analyzing status, all the thumbnails belong to the exam are displayed.
- When you move the cursor onto a thumbnail, its name and format will be displayed.

10.2.7 Image Review and Analysis

You can review and analyze the stored images (only refer to the images stored in the system default path).

10.2.7.1 Review an Image

You can review all images stored in an exam, and send, delete or analyze the stored images.

- To enter image review:
 - During image scanning, saved image thumbnails will display at right part of the screen. Move the cursor onto a thumbnail, and press <Set> twice to open the image; if the stored image is a cine file, double-click the thumbnail to enter the auto cine review.
 - Press <Review> to enter the Review screen. Images of the current exam and the current patient are displayed.
 - Select an exam of a patient in the iStation screen, and press <Review> or double-click the exam to enter the Review screen to review the images of the patient.

The Review screen is shown as follows:

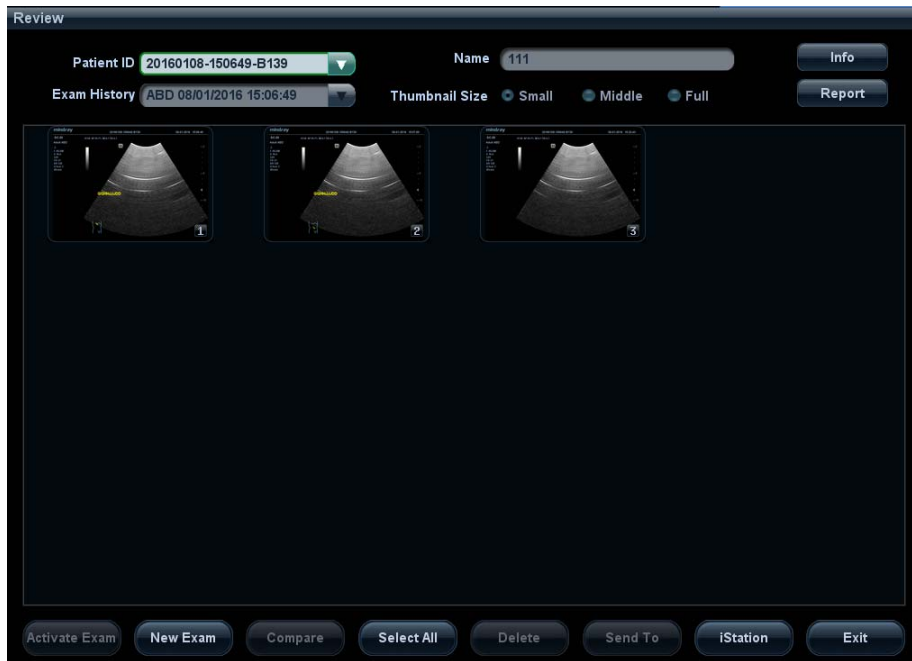

- To exit Review:
 - Click [Exit] on the Review screen
 - Press <Esc>
- Basic operations

Select an exam from the “Exam History” drop-down list.

The function buttons are described as follows:

 - Exam History:

You can select one certain exam from the exam directory to review the images.

 - If entered from iStation, the screen displays the record(s) selected in the iStation.
 - If entered from the imaging status, the Review screen displays the images of the current exam, and the default selected image is the one displayed on the preview main screen.
 - Info

Click to enter the Patient Info screen, you can review or edit the currently-selected patient information.
 - Report

Click to review or edit the currently-selected patient report.
 - Image operations

[Select All]: click to select all images in the thumbnail window.

[Deselect All]: after clicking the [Select All], the button changes into [Deselect All], you can cancel all the selections by clicking [Deselect All].

[Send To]: click to send the selected image to other location, DICOM server, printer, MedTouch/MedSight, etc. Or, select the image and click the ➡ icon on the upper left of the image.

[Delete]: click to delete the selected image.
 - Thumbnail Size

To change the thumbnail size.
 - Other operations:

- [New Exam]: click to create a new exam for the selected patient and open the Patient Info screen.
- [Activate Exam]: activate the currently selected exam (ended already) and enter the image scanning screen.
- [iStation]: click to enter the iStation screen.
- [Exit]: click to exit the Review status, and return to the main screen.

10.2.7.2 Image Analysis

In the image analysis status, you can view, zoom, perform post processing and measurements, add comments and perform cine (multi-frame) review for a stored image (FRM or CIN format). The operation steps are the same as those for real-time scanning; please refer to relevant sections for details.

- To enter image analysis:
 - In the image scanning or freeze status, double-click a thumbnail stored in this exam to enter the image analysis status; or
 - In the image review status, double-click the selected thumbnail to open the image.
- To exit image analysis:
 - Press <Freeze> to exit and enter the real-time scanning status.
 - Press <Review> or click [Return] to exit from the image analysis to the Review status.

In image analysis status, the selected image is displayed on the screen, and the thumbnails of the same exam are displayed on the thumbnail area, you can turn pages, change image display format using the buttons below the thumbnail.

- Other operations

You can perform operations of cine review in image analysis status, for details, please refer to “6 Display & Cine Review”.

10.2.8 iVision

iVision function is used for demonstration of the images stored. Image files are played according to file names one by one (including the image of system-relevant and PC-compatible format).

To perform image demonstration:

1. Enter iVision screen:
 - Move the cursor onto [iVision] in the Other menu, and press <Set>.
 - Press the user-defined key (setting path: [Setup]→[System Preset]→[Key Config]→[Other]).
2. Add the contents to be played and select the demo mode.
3. Select an item in the list, and click [Start] to begin the demonstration.
4. Click [Exit] or press <Esc> to exit the iVision status.

The iVision screen is shown as follows:

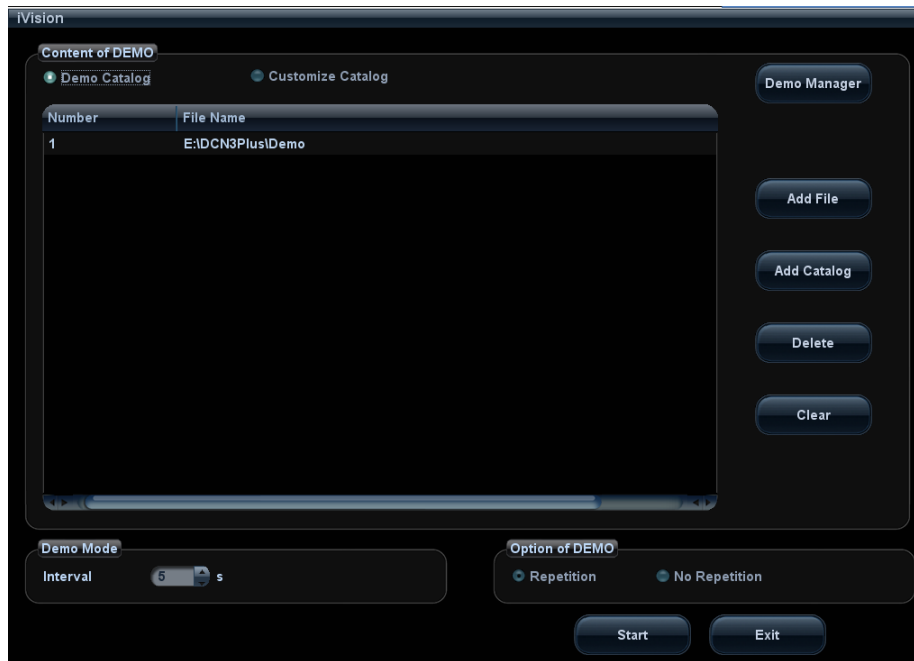

■ Demonstration item

The demonstration items are the image files in the formats that the system supports. You can add the exam data in patient database (D:\PatientData) or system supported image files and folders to demonstration item list. For files and folders in demonstration list, the images in the directory and subdirectory are played one by one, and the system will automatically jump over the files that can't be opened.

■ Demonstration item

There are two kinds of catalogs: Demo Catalog and Customize Catalog.

- Demo Catalog: demo catalog is the folder in hard disk (E disc), where the factory DEMO is stored. The system plays the images in this folder when performs demonstration.

The system supports import, delete or clear the data in demo catalog.

Click [Demo Manager] to operate:

: To import data to demo catalog.

: To delete the selected data.

: To delete all data.

- Customize Catalog: what saved here is the catalog of the displayed image. The system plays the images in the catalog when performs demonstration.

Operate the catalog by the buttons on the right:

[Add File]: to add files to the file list.

[Add Catalog]: to add catalog to the file list.

[Delete]: to delete the selected file or catalog in the file list.

[Clear]: to clear all the files or catalogs in the file list.

Select or deselect the directory/file by checking or un-checking the check box before the file list, only the selected directories/files will be replayed.

■ Demo mode

The system automatically plays all the image files in the list one by one. The time intervals between images played can be changed through the drop-down list of "Interval".

- Option of Demo

You can choose whether to repeat the demonstration or exit after a demonstration is completed.

10.2.9 Sending Image File

- On the image screen, select a stored image thumbnail (press <Shift> to select more than one at the same time), click  (Send To) on the lower right corner of the screen, the image can be sent to the external devices.

- In the iStation or Review screen, click [Send To] to send the selected image to the external devices.

See the figure below.

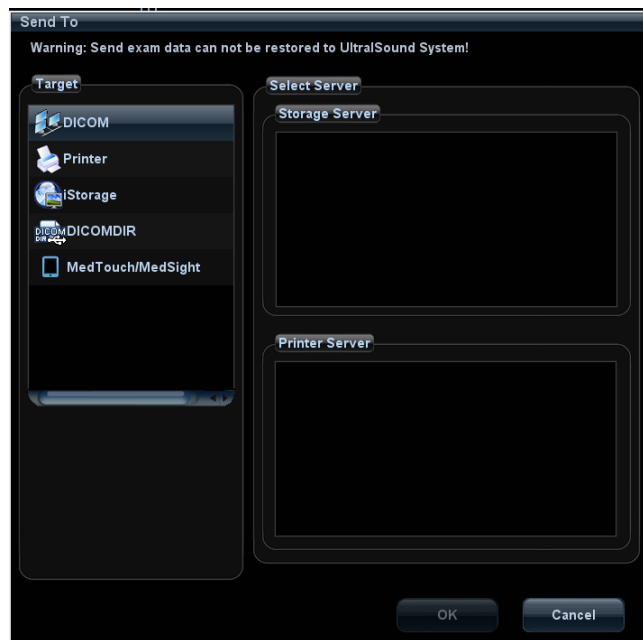

- For external memory devices (e.g. USB memory devices, DVD-RW or network storage server):
 - a) PC format transfer: JPG/ AVI, BMP/ AVI, TIFF/ AVI. Where a single-frame image is exported as JPG, TIFF or BMP, and the cine file exported as AVI.
 - b) DCM format transfer: DCM (including single-frame DCM and multi-frame DCM).
 - c) You can also select to export report format.
 - d) Select the cine zoom mode.
- For DICOM Storage or Print server, select the DICOM Storage or Print server.
- For a video printer, send images to the video printer connected with the system. For a graph/ text printer, send the images to the default graph/ text printer.
- For MedTouch/MedSight devices, single-frame image will be saved in PNG format, and multi-frame image will be saved in AVI format.

10.3 Report Management

- Report storage

The exam reports are stored under the directory of the exam of the patient.

- Importing, exporting and sending a report

In the iStation screen, select patient data, click [Restore Exam] or [Backup Exam] to import or export patient information, images and reports from or to an external memory device or network storage server.

You can also select whether to remove local patient exams data or only images after backup.

See the following figure:

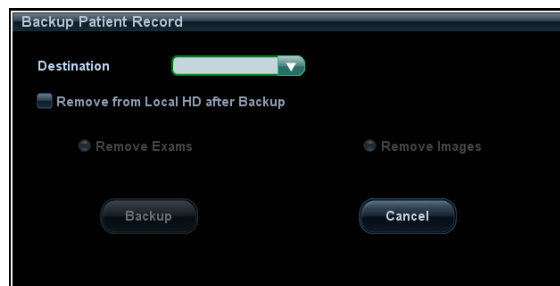

In the iStation or Review screen, click [Send Exam] to send patient data to an external memory device or network storage server, you can choose if reports are exported with images. See the figure below.



- To export the report

(1) Check [Report]→[Export] on the screen, and select the exported format, RTF or PDF.

(2) Click [OK] to confirm.

You can select paper size for the report in the path: [Setup]→ [Print Preset]→ [Print Service].

- Printing report

Use a connected graph/text printer to print a report.

For details on report relevant operations, please refer to [Advanced Volume].

10.4 Patient Data Management (iStation)

The patient data include basic patient information, exam information, image files and reports. You can search, view, backup, send, restore or delete patient data in iStation.

- To Enter iStation
 - Press <iStation> key on the control panel; or
 - Click [iStation] in the Patient Info screen; or
 - Click [iStation] in the Review screen.

The iStation screen is shown as follows:



10.4.1 Viewing Patient Information

- Data Source
 - Select the data source of patient data, and the system patient database is default.
- Patient list
 - Display patient information, exam mode, number of images and cines, exam state, backed up or not.
- New Exam
 - After you select a patient data or exam in the iStation screen, click the [New Exam] to enter the Patient Info screen, where you can select the exam mode and click [OK] to begin a new exam.
- Select All/Deselect All
 - Click [Select All] to select all the patient data listed. Then the button changes into [Deselect All], you can cancel all the selections by clicking [Deselect All].

10.4.2 Searching a Patient

1. Select the data source.
2. Set search conditions of Name, ID, DOB, Exam Date in the "Item" drop-down list.
3. Enter the keyword in accordance with the "Item" selected, and the system searches and displays the results in the patient list.
4. When you select a patient in the patient list, images of this patient will be displayed at the bottom of the screen.

10.4.3 Patient Data View & Management

Select the desired patient information in the list. The following menu pops up:

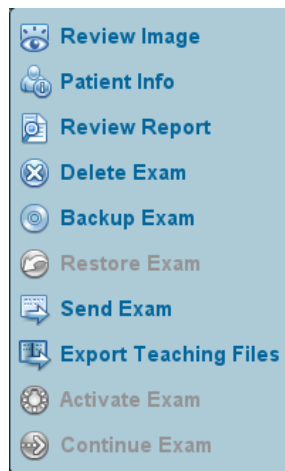

- Review an Image
Select an exam of a patient, click [Review Image] to enter Review screen.
- Patient Information
Select an exam of a patient, click [Patient Info] to check the patient information of this exam.
- Review Report
After you select an exam of a patient, click [Review Report] to view the report of this exam for this patient.
- Delete Exam
Select an exam record, click [Delete Exam] to delete the record. However, you cannot delete patient data being printed, exported or sent, or delete the current exam.
 - To delete an image, select the image first and then click  on the upper right side.
- Backup/ Restore
You can back up the selected patient data to the system-supported media in order to view it on PC, or restore the patient data to the system from an external media.
 - [Backup Exam]: click to back up the selected patient data to the system-supported media. The backup data can be restored to the ultrasound system.
 - You can select whether to remove images or the whole exam record from the system.
 - [Restore Exam]: click to import the patient data from an external media.

■ Send Exam

The system supports to send data to external memory devices or print.

- Select the patient record, click [Send Exam] in the menu to send exam data or images of the selected record.
 - Send patient exam data to USB devices, DVD-RW/DVD+RW drive.
 - Send images to USB devices, disc, DICOM storage server, DICOM printer, video printer, text/ graph printer.
 - Send exam data with report to USB devices, DVD-RW/DVD+RW drive.
 - Format transfer is available when sending images to USB devices or disk.
 - Send to DICOMDIR: adjust the cine zoom mode, compression mode and JPEG compression size.
 - Press <Control> or <Shift> with <Set> key on the control panel to select more than one exam or image at one time.
 - MedTouch/MedSight: send the exam to MedTouch/MedSight devices for review.

■ Export teaching file

Select the patient record, click [Export Teaching Files] in the menu to export exam data or images of the selected record.

- You can select to transfer image format.
- Select Patient Info to be “Default Info”, the system deletes the patient name automatically of the exported file.
- Select Patient Info to be “Custom Info” and you can rename the patient name to keep the patient information safe.

■ Activate an Exam

After you select an exam, which has been performed within 24 hours, click [Activate Exam] to activate the exam and load the basic patient information and measurement data to continue the exam.

If you want to select a patient data in an external memory database to start a new exam or recover the exam, you have to first allow the system to load the patient data to the system's patient database.

■ Continue Exam

Select an exam that is paused within 24 hours, click [Continue Exam] to activate the exam and load the basic patient information and measurement data to continue the exam.

If you want to select a patient data in an external memory database, you have to first allow the system to load the patient data to the system's patient database.

■ Recycle bin

The recycle bin is used to store the deleted patient data, exam data and images (time lasts from deleting to system is powered off). The system supports recovery of those data from the recycle bin. Deleted data from the recycle bin will be cleared after the system is powered off.

To recover the deleted patient data, click  at the lower right corner of the screen (when the button is gray, the operation is unavailable) to enter the Patient Recycle Bin screen.

(1) Select items to be recovered in the list. Select operations:

- Click [Restore Items] to restore the item back to iStation.
- Click [Delete] to delete the item permanently, and the item can never be restored again.
- Click [Restore All Items] to restore all the items back to iStation.

- Click [Empty Recycle Bin] to empty the recycle bin and all items can never be restored again.
- (2) Click [Exit] to exit Recycle Bin screen.

10.5 iStorage

iStorage is used to save image files and measurement reports to the remote PC server. Open “[Setup]→[Network Preset]→[iStorage]” to set the iStorage settings.

1. Enter the iStation screen. Select one (or more than one) patient data or image in the local data source.
2. Click [Send Exam].
3. Select [iStorage] in the Send To dialog box and select the PC server on the right.
4. Select PC transfer format to send the report.
5. Click [OK] to start sending.

10.6 Print

10.6.1 Setting

■ Print Service Setting

- (1) Open the [Setup]→[Print Preset], select an existed printer service in the list.
- (2) Select the printer type in the Property box.
- (3) Set printing properties.
- (4) Click [Save] to confirm the setting and exit the preset page.

■ User-defined shortcut key for printing

To use [Print] key on the control panel of the system, you should:

- (1) Press the [Setup] key to show the Setup menu, click [System Preset] item to open the [System Preset] screen, and click [Key Config] tab.
- (2) Click to select [Print] on the left side. Click to select desired print method in the right side.
- (3) Click [Save] to exit the preset and make the settings effective. Press the [Print] key on the control panel to print.

■ Video output settings:

Open [Setup]→[System Preset]→[General], then select the image output mode.

Open [Setup]→[System Preset]→[General], then select the image storage size.

10.6.2 Image Print

Image printing is mainly performed by video printer, and for DICOM image printing, refer to DICOM chapter.

1. Select the desired image in iStation or Review screen.
2. Click  icon on the upper right side of the image, and select the printer in the popped up dialogue box.
3. Click [OK] to start printing.

Please refer to the accompanying manuals of the printers for more details.

10.6.3 Report Print

Both report and image can be printed on a graph / text printer.

1. Press <Report> to enter the report dialog box.
2. Select [Print] to print the report.



Please refer to the accompanying manuals of the printers for more details.

10.7 Backup Files through DVD Drive

The system supports CD-R/RW, DVD±RW drive to write data in CD/DVD and to read data from CD/DVD in PC.

The system supports the following media: CD-R/RW, DVD±RW.

■ To write data to a CD/DVD:

- (1) Put a CD/DVD in the tray.
- (2) Select the data to be backed up, select [Send Exam] or [Backup Exam] in the popped up menu. Select the target drive in the Send To or Backup Patient Record dialogue box.
- (3) Click [OK] or [Backup] to begin writing, with the symbol displays as .
- (4) After the writing process is completed, click  to pop up the Disc Option dialogue box, and select [Eject] to eject the CD/DVD.

Tips:

- Writing data using “Send To” supports PC format transfer function, while CD/DVD written by “Backup” supports only system-relevant formats.
- The  symbol indicates that the input CD/DVD is damaged or with data of wrong format.

You can check the data writing procedure in patient task manager, for details, please refer to “10.8 Patient Task Management”.



CAUTION:

During the backup process, if a CD/DVD is forcibly taken out or if you perform other operations, the backup process will fail or the system may malfunction.

10.8 Patient Task Management

Click  at the lower right corner of the screen to pop up the following dialogue box:



The system supports four types of task management:

- Storage Task: displays the DICOM storage task.
- DICOM Print Task: displays the DICOM print task.
- Media Storage Task:
 - DICOM media storage task(including disc and USB devices)
 - Backup task (system-relevant format): select the exam to be backed up in iStation and click [Backup].
 - Send to external devices (including disc and USB devices): select exam data or images in iStation or Review screen, click [Send Exam] or ➔ of the image.
- Print Task: displays image or report printing task.

In the Task Management dialogue box, patient ID, name, destination, progress, type, contents and task created time are displayed.

You can do the following operations:

- Click [Delete] to delete the task.
- Click [Retry] to retry the failed task.
- Click [Select All] to select all the tasks.
- Task Status

When there is/are task(s) undergoing, the task management icon displays as , you can click the icon to check the process.

When there is/are task(s) failed, the task management icon displays as , you can click the icon to check the failure reason.

When the task management icon displays as , it means no task is undergoing or failed.

- **DICOM Service Setting**

In the Storage Task and DICOM Print Task page, click [Service Setting] to enter the DICOM service setting screen. For details, please refer to DICOM chapter.

- **Troubleshooting**

- If any serious error occurred like network disconnection or operation timeout, the system can try to reconnect the network. The interval time and maximum retries can be set, for details, please refer to DICOM chapter.

10.9 Administration

10.9.1 Access Setting

The system support two types of users: the system administrator and operator.

- **Administrator**

The system administrator can view all patient data, such as patient information, image and report, etc.

- **Operator**

The operator can only view the exam information saved in the system and operated by himself or herself, such as patient information, image and report, etc. The operator can't view the exam data operated by others.

10.9.2 Setting Access Control

The system administrator can preset the access control, that is, if an operator has the right to access to the data in the system.

The access control only can be set by the system administrator.

Setting access control:

1. Open the "Admin" page through the path: [Setup]→[System Preset]→[Admin].
2. If **Enable User Account Control** is selected, you need to have the authority before accessing the data. If unselected, you can access all the data without the authority.

10.9.3 System Login

If access control has been set by the system administrator, you can access the data in the system only after you log on the system.

You need to enter user name and password in the following cases:

- Before entering the system
- Changing user

You need to login again after system restart or dormancy.

- **Log on the system:**

- (1) The following dialogue box pops up:

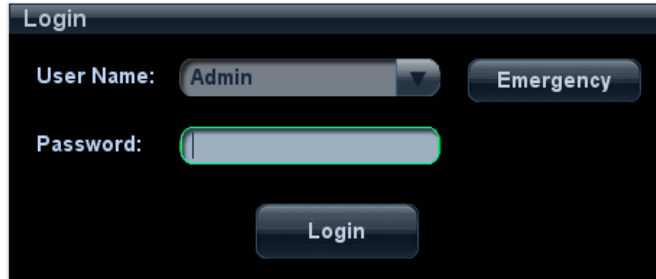

- (2) Select the user name in the drop-down list of User Name.
- (3) Enter password and click [Login].

■ To change user:

- (1) To log out the current user and change to another user, click  at the lower right corner of the screen to pop up the following dialogue box:

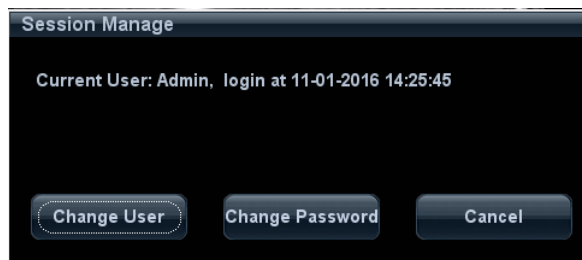

- (2) Click [Change User] to pop up the Login dialogue box.
- (3) Enter the user name and password in the field box.

NOTE: You have to exit the Preset screen before changing the user.

10.9.4 Adding/Deleting a User

The system administrator can add and delete a user, while the operator can't.

Add a User

Premise: you must log on the system as the system administrator. If not, you will be required to enter administrator name and password before the setting.

1. Open the "Admin" page through the path: [Setup]→[System Preset]→[Admin].
2. Click [Add] to pop up the following dialogue box.

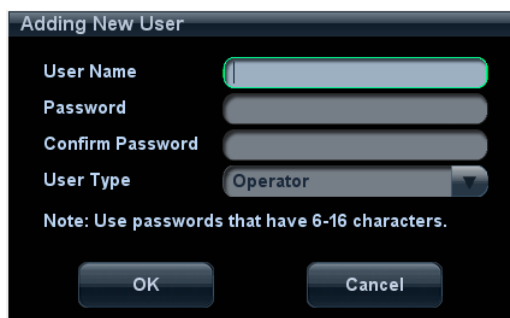

3. Enter user name.
4. Enter the password and the confirmed password.
5. Set the user role in the drop-down list: administrator or operator.

6. Click [OK] to confirm the setting and exit the dialogue box, then the new user will appear on the User List.

Delete a User

Premise: you must log on the system as the system administrator. If not, you will be required to enter administrator name and password before the setting.

1. Open the “Admin” page through the path: [Setup]→[System Preset]→[Admin].
2. Select the user to be deleted in the User List, click [Delete] to delete the selected user.

10.9.5 Modify Password

The system administrator can modify password of all users. The administrator password by factory is empty; you can set the password for it.

The operator can only modify his/her own password. There are two ways to modify password: modify it on “Admin” page or on “Session Manage” dialogue box.

- “Admin” page (administrator can modify the password)
 - (1) Open the “Admin” page through the path: [Setup]→[System Preset]→[Admin].
 - (2) Select the user name to be modified in User List, click [Change Password] to open the dialogue box.
 - (3) Enter new password and confirm the password, then click [OK].
- Session Manage page (general operator and administrator can modify the password)

When the user has logged on the system, you can see  at the lower right corner of the screen.

- (1) Click  at the lower right corner to pop up the Session Manage dialogue box, on which you can see the current user’s information.
- (2) If you want to modify the current password, click [Change Password] to pop up the Change Password dialogue box.



The image shows a 'Change Password' dialog box with a dark background. It contains the following fields and text:

- Header: Change Password
- User name: Admin
- Current Password: [Text input field]
- New Password: [Text input field]
- Confirm New Password: [Text input field]
- Note: The password must consist of 6-16 characters.
- Buttons: OK and Cancel

- (3) Enter the previous and the new password in the dialogue box.
- (5) Click [OK] to exit.

11 DICOM

NOTE: Before using DICOM, please read the electronic file DICOM CONFORMANCE STATEMENT along with the device.

This chapter is confined to the preset, connection verification and DICOM services of the DICOM-configured ultrasound machine, not including SCP configurations like PACS/ RIS/ HIS.

The DICOM package is optional, so the description here is only applicable for the system configured with the DICOM package.

This system supports the following DICOM functions:

- Verify Connectivity
- DICOM Storage
- DICOM Print
- DICOM Worklist
- MPPS (Modality Performed Procedure Step)
- Storage Commitment
- Query/Retrieve
- Structured Report
- DICOM Medium Storage (DICOMDIR Review)
- DICOM Task Management

Workflows of DICOM Preset and Applications are briefly described as follows:

1. DICOM preset (network property, DICOM local preset, server and service preset).
2. Verify connectivity.
3. Services application.
4. DICOM task management.

11.1 DICOM Preset

11.1.1 Network Preset

Refer to “12.5 Network Preset” for details.

11.1.2 DICOM Local Preset

1. Enter the DICOM local preset screen through the path: [Setup]→[DICOM Preset].
2. Enter AE Title, Port, and PDU according to the actual situation, and then click [Save] to exit the screen, setting items are introduced in the following.

Name		Description
DICOM Local	AE Title	Application Entity title.
	Port	DICOM communication port.
	PDU	Maximum PDU data package size, ranging from 16384 to 65536; if the value is less than 16384 or greater than 65536, the system automatically sets it to the value 32768.
Server Setting	Device	Name of the device supporting DICOM services.
	IP Address	IP address of the server.
	Ping	You can ping the other machines after you entered the correct IP address. Besides, you can select a server in the Device list to ping it.
	Device List	Displays the added device.
	Set DICOM Service	Provides server settings of DICOM service, for details, please refer to the following chapters.
	Add	Click to add server (s) to the Device List.
	Delete	Click to delete the selected server (s) in the device list.

■ Server setting procedure:

- (1) Enter the server device name and IP address; click [Ping] to check the connection.

- (2) Click [Add] to add the server to the device list, and its name and address are displayed in the list.

Tips:

AE Title should be the same with the SCU AE Title preset in the server (PACS/RIS/HIS), for example, if the AE Title of the server preset in the storage server is Storage, and the AE Title of the accepted SCU is preset as Machine, then in the figure above, the AE Title of Local should be Machine, and the AE Title of storage server should be Storage.

11.1.3 Service Preset

The DICOM Service screen is used to set attributes of Storage, Print, Worklist, MPPS, Storage Commitment, and Query/Retrieve.

When the system is configured with DICOM basic function module, and installed with DICOM Worklist, MPPS, DICOM structured report, and DICOM query/retrieve modules, the corresponding preset can be found in DICOM Service screen.

To open the DICOM Service screen:

1. Press <F10> key to show the Setup menu.
2. Navigate to select [DICOM Preset], and click [Set DICOM Service] to open the DICOM Service preset screen.

11.1.3.1 Storage Service Preset

1. On DICOM Service screen, click [Storage] page tab to enter the Storage page.
2. Select device, enter the right AE Title, port, etc.
3. Click [Add] to add the service to the Service List.

DICOM Service

Storage | Print | Worklist | MPPS | StorageCommitment | Query/Retrieve

Configure the New Service

Device: [Dropdown] Service Name: [Text] AE Title: [Text] Port: 104

Maximum Retries: 3 Interval Time(Sec): 15 Timeout(Sec): 15

Color Mode: Color Compression Mode: RLE Compression Ratio: Lossless

Allow Multiframe Max Framerate: 35

SR Storage Option: Not Store SR

Add | Cancel | Update

Service List

Device	Service Name	AE Title	Port	Default

Delete | Default | Verify | Verification is required!

Exit

DICOM storage preset items are described as follows:

	Name	Description
Configure New Service	Device	After you set the server (s) in DICOM Preset screen, the name (s) will appear in the drop-down list, select the name of the storage server.
	Service Name	Default is xxx-Storage, user-changeable.
	AE Title	Application Entity title, here, it should be consistent with that of the storage server.
	Port	DICOM communication port, 104 is default. Here, the port should be consistent with that of the storage server port.
	Maximum Retries	Set the maximum retries.
	Interval Time(s)	Interval time that the system retries a connection.
	Timeout	Refers to the amount of time after which the system will stop trying to establish a connection to the service.
	Compression Mode	Select the compression mode: uncompressed, RLE, JPEG, and JPEG2000.
	Compression Ratio	Select the JPEG compression ratio: lossless, low, medium, and high.
	Color Mode	Select the color mode.
	Allow Multiframe	If SCP supports this function, then select it.
	Max Frame Rate	Set the frame range of transferring cin file into DCM multi-frame file.
	SR Storage Option	To enable or disable structured reporting sending.
	Service List	Add
Cancel		Click to cancel parameter setting.
Update		Select an item in the service list, change the parameters in the above area, and click [Update] to update the item in the service list.
Delete		Click to delete the selected service in the service list.
Default	Select an item in the service list, click [Default] and you can see "Y" in the Default column.	
Verify	Click to verify if the two DICOM application entities are normally connected.	

Tips: RLE, JPEG and JPEG2000 are not supported by all SCPs. Please refer to the electronic file DICOM CONFORMANCE STATEMENT of the SCP to check whether SCP supports or not. Do not select these compression modes if the storage server doesn't support them.

11.1.3.2 Print Service Preset

1. On DICOM Service screen, click [Print] page tab to enter the Print page.
2. Select device, enter the right AE Title, port, etc.
3. Click [Add] to add the service to the Service List.

DICOM print preset items are described as follows:

	Name	Description
Configure the New Service	Device	After you set the server (s) in DICOM Preset screen, the name (s) will appear in the drop-down list, select the name of the print server.
	Service Name	Default is xxx-Print, user-changeable.
	AE Title	Application Entity title, here, it should be consistent with that of the print server.
	Port	DICOM communication port, 104 is default. Here, the port should be consistent with that of the print server port.
	Maximum Retries	Set the maximum retries.
	Interval Time (s)	Interval time that the system retries a connection.
	Timeout	Refers to timeout during association establishment.
Print Properties	Copies	Refer to copies of printed files. You can select among 1 through 5, or directly enter the numeral.
	Settings	The system supports RGB (color printing) and MONOCHROME2 (black and white printing). Please select the type the printer supports.

Name	Description	
Film Orientation	Select between LANDSCAPE and PORTRAIT.	
Priority	Specify printing task priority among HIGH, MED and LOW.	
Film Size	Select film size among the selections listed in the drop down list.	
Display Format	Specify quantity of printed files, e.g. STANDARD\2, 3 indicates 6 images are printed for each page.	
Medium Type	Specify print medium: Paper, Clear Film, Blue Film; select Blue Film or Clear Film for black and white printing; select Paper for color printing.	
Trim	Specify whether you want a trim box to be printed around each image on the film: Yes or No.	
Configuration Info	Enter configuration information in the field.	
Min Density	Enter the minimum density of the film.	
Max Density	Enter the maximum density of the film.	
Destination	Specify where the file is exposed: MAGAZINE (stored in the magazine), or, PROCESSOR (exposed in the processor).	
Magnification Type	<p>Select how the printer magnifies an image to fit the film.</p> <p>Replicate: interpolated pixels belong to duplicate of adjacent pixels);</p> <p>Bilinear: interpolated pixels are generated from bilinear interpolations between adjacent pixels;</p> <p>Cubic: interpolated pixels are generated from cubic interpolations between adjacent pixels;</p> <p>None: without interpolation.</p>	
Add	Add the DICOM service to the service list	
Cancel	Click to cancel parameter preset.	
Update	Select an item in the service list, change the parameters in the above area, and click [Update] to update the item in the service list.	
Service List	Delete	Click to delete the selected service in the service list.
	Default	Select an item in the service list, click [Default] and you can see "Y" in the Default column.
	Verify	Click to verify if the two DICOM application entities are normally connected.

11.1.3.3 DICOM Worklist Preset

1. On DICOM Service screen, click [Worklist] page tab to enter the Worklist page.
2. Select device, enter the right AE Title, port, etc.
3. Click [Add] to add the service to the Service List.

DICOM Worklist service parameters are similar to those described in DICOM Storage Preset, please refer to “11.1.3.1 Storage Service Preset” for details.

11.1.3.4 MPPS Preset

1. On DICOM Service screen, click [MPPS] page tab to enter the MPPS page:
2. Select device, enter the right AE Title, port, etc.
3. Click [Add] to add the service to the Service List.

DICOM MPPS service parameters are similar to those described in DICOM Storage Preset, please refer to “11.1.3.1 Storage Service Preset” for details.

11.1.3.5 Storage Commitment Preset

1. On DICOM Service screen, click [Storage Commitment] page tab to enter the Storage Commitment page.
2. Select device, enter the right AE Title, port, etc.
3. Click [Add] to add the service to the Service List.

Special setting item for DICOM Storage Commitment service is Associated Storage Service, as described in the following; other parameters are similar to those described in DICOM Storage Preset, please refer to “11.1.3.1 Storage Service Preset” for details.

Name	Description
Associated Storage Service	The associated storage server should be preset before storage commitment, only after the exam is sent out, can storage commitment be created.

11.1.3.6 Query/Retrieve Preset

1. On DICOM Service screen, click [Query/Retrieve] page tab to enter the Query/Retrieve page.
2. Select device, enter the right AE Title, port, etc.
3. Click [Add] to add the service to the Service List.
4. Click [Exit] to confirm the preset and exit the page.

DICOM Query/Retrieve service parameters are similar to those described in DICOM Storage Preset, please refer to “11.1.3.1 Storage Service Preset” for details.

11.2 Verify Connectivity

If you want to verify connectivity (it is not a must-do operation), you can click [Verify] button on Storage, Print, Worklist, MPPS, Storage Commitment, and Query/Retrieve pages respectively.

If the verification succeeded, the system prompts “xxx Verify Succeed”. Otherwise, it prompts “xxx Verify Failed”.

If verification failed, the possible causes may be:

- The ultrasound machine can't communicate normally with the server. Please check if the cable is properly connected; or,
Check if the IP of the server is configured in the same segment with that of the ultrasound machine; or,
Check if the network adapter, the router, the exchanger or the HUB are normally working.
- The server does not support the verification. If the connection is normal, it can be concluded that the server does not support the verification.
- The server supports the verification, but this function is not activated. Please check if the verification function is activated.

Tips:

Not all the SCPs can support verification; please consult SCP belongings to confirm whether SCP can support this service. If not, the verification won't pass.

11.3 DICOM Services

If you completed all DICOM presets on DICOM Service Preset screen. Now you are ready for Storage, Print, Worklist, MPPS, Storage Commitment, and Query/Retrieve applications.

11.3.1 DICOM Storage

DICOM Storage is used to send image (s) to DICOM storage server for storage.

■ Send image on iStation/Review/main screens

(1) Select image (s)

- Press <iStation> on the control panel to open the iStation screen, click to select a patient or an exam record in the list, thumbnails are displayed in the thumbnail area in the lower part of the screen, then click to select a thumbnail or several thumbnails. Or,
- Press <Review> on the control panel to enter the Review screen, click to select a thumbnail or several thumbnails. Or,
- On the main screen, select a thumbnail or several thumbnails.

(2) Click  at the upper right part of the image to pop up the following dialogue box.



- (3) Click to select “DICOM” in the Target box on the left side, and then select the DICOM storage server in the Storage Server box on the right side.
- (4) Click [OK] to start the sending.
- (5) Tap [Send To] on the touch screen.

■ To send images by shortcut key

You can save single frame image or multi-frame images to DICOM server while saving to hard drive by shortcut key. Procedures are described as follows:

- (1) Define the key:
 - a) Open Key Config page via “[Setup] (F10)→[System Preset]→ [Key Config]”.
 - b) Assign functions to the desired keys: in Key Config page, select a free key or footswitch at the left side, then select the corresponding key on the right side.
 - Save Image to Hard Disk and Send to DICOM Storage
 - Save Cine (Retrospective) to Hard Disk and Send to DICOM Storage.
 - Save Cine (Prospective) to Hard Disk and Send to DICOM Storage.
 - c) Click [Save] to confirm the preset and exit.
- (2) Set a default storage server:
 - a) Enter the DICOM Service Preset screen via “[Setup] (F10) → [DICOM Preset] → [Set DICOM Service]”.
 - b) Select a storage server in the Service List and click [Default]; you can see “Y” is marked in the Default column.
 - c) Click [Exit] to exit the page and return to Setup menu, then click [Save] on the Setup menu to make the preset to take effect.
- (3) Press the key to send DICOM storage.

- To send image for storage after an exam ends
 - (1) Open “[Setup] (F10) → [System Preset] → [General]”, and then check  in the Exam Setup area.
 - (2) Set a default storage server.
 - a) Enter the DICOM Service Preset screen via “[Setup] (F10) → [DICOM Preset] → [Set DICOM Service]”.
 - b) Select a storage server in the Service List and click [Default]; you can see “Y” in the Default column.
 - c) Click [Exit] to exit the page and return to Setup menu, then click [Save] on the Setup menu to make the preset to take effect.
 - (3) When finished the presets, you can perform image scanning, each time you press <End Exam> on the control panel, the system will send the image to the default DICOM storage server for storage.

11.3.2 DICOM Print

DICOM Print is used to send image(s) to DICOM print server for printing.

- Print image in iStation/Review/main screens
 - (1) Select image(s), operations are the same with DICOM storage.
 - (2) In the Send To dialogue box, select a DICOM print server (For the dialogue box, please refer to DICOM Storage).
 - (3) Click [OK] to begin the printing.
- To send images by shortcut key

You can send single frame image to DICOM print server while saving to hard drive by shortcut key.

 - (1) Define the short key:
 - a) Open Key Config page via “[Setup] (F10) → [System Preset] → [Key Config]”.
 - b) Assign functions to the desired keys: in Key Config page, select a free key or footswitch at the left side, then select “Save Image to Hard Disk and Send to DICOM Printer” on the right side.
 - c) Click [Save] to confirm the preset.
 - (2) Set a default printer server
 - a) Enter the DICOM Service Preset screen via “[Setup] (F10) → [DICOM Preset] → [DICOM Service]”.
 - b) Click [Print] to open the Print page.
 - c) Select a Print server in the Service List and click [Default]; you can see “Y” is marked in the Default column.
 - d) Click [Exit] to exit the page and return to Setup menu, then click [Save] on the Setup menu to make the preset to take effect.
 - (3) Press Key1 (defined as shortcut key for Save Image to Hard Disk and Send to DICOM Printer), the system captures the current screen and sends it to the print server.
- To print image for storage after an exam ends
 - (1) Open “[Setup] (F10) → [System Preset] → [General]”, and then check  in the Exam Setup area.
 - (2) Set a default print server.
 - a) Enter the DICOM Service Preset screen via “[Setup] (F10) → [DICOM Preset] → [DICOM Service]”.

- b) Click [Print] to open the Print page.
 - c) Select a Print server in the Service List and click [Default]; you can see “Y” is marked in the Default column.
 - d) Click [Exit] to exit the page and return to Setup menu, then click [Save] on the Setup menu to make the preset to take effect.
- (3) When finished the presets, you can perform image scanning, each time you press <End Exam> on the control panel, the system will send the image to the default DICOM print server for printing.

11.3.3 DICOM Worklist

After successfully connected DICOM Worklist server with ultrasound system, you can query patient records from Worklist server, and then import the desired information to your system.

- To query patient information via Worklist server
 - (1) Press the < Patient > key to open the Patient Info screen.
 - (2) Click [Worklist] to enter the Worklist page.

Worklist

Query

Patient ID Patient Name Accession #

Search Key Worklist Server

Exam Date To Modality Type

Scheduled Station AE Title

0 records are listed.

Patient ID	Patient Name	Accession #	Exam Description	Exam Date	Gender	DOB

02:07:40

- (3) Query patient information:
 - a) Set query criteria among Patient ID, Patient Name, Accession #, Search Key, Scheduled Station AE Title, Worklist Server or Exam Date. The default exam date is the current date.
 - b) Click [Query].
 - c) The scheduled patients, which meet the criteria, are displayed in the lower part of the screen.
 - d) After you finished the first query, you can perform the second query basing on the previous results. The scheduled patients in the list will update in real time.

- (4) Select the desired patient record in the displayed patient list:
 - a) Select the desired patient and click [Start Exam], the patient information is imported into the system and then an exam is started.
 - b) Click [Transfer], the patient information is imported into the [Patient Info] screen. After you edited the patient information in the Patient Info screen, select [OK] to start a new exam.
- (5) To show patient information in details:
 - a) Click to select a patient record.
 - b) Click [Show Detail] button to view the detailed patient information and properties.
- To automatically query via Worklist server
 - (1) Enter DICOM Service Preset screen, click [Worklist] page tab to open Worklist page.
 - (2) Select an item in the service list and click [Default] to set it as default.
 - (3) Click [Exit] in the screen and click [Save] in the Setup menu.
 - (4) Press <Patient> key on the control panel to open Patient Info screen.
 - (5) Click [Worklist] button to open Worklist screen.
 - (6) The system automatically queries intraday patients via Worklist server and the patient records will appear in the list.

In the off-line status, you can:

- Perform the second query; or,
- Click [Show Detail] button in the Worklist screen to view the detailed patient information.

11.3.4 MPPS

MPPS is used to send exam state information to the configured server. This will facilitate the other systems to obtain the exam progress in time.

The status information is described as below:

- When you begin an exam or send image(s) during the exam, the system sends status information "Active" to MPPS server.
- When the exam is completed, the system sends status information "End" to MPPS server.
- When a paused exam is continued, the system sends status information "Active" to MPPS server.
- When an exam is cancelled, the system sends status information "Cancelled" to MPPS server.

11.3.5 Storage Commitment

Storage commitment is used to confirm whether the images or structured reports are successfully stored to the DICOM storage server.

Before storage commitment, you should set the default storage commitment server.

- Storage commitment after sending images on iStation screen.
 - (1) Open iStation screen.
 - (2) Select an exam (a suspended exam or an exam not active) (image (s) is/are stored in the exam record), click [Send Exam] button in the popped up menu to open the Send To dialogue box.
 - (3) Click to select "DICOM" in the Target box on the left side, and then select the DICOM storage server in the Storage Server box on the right side.
 - (4) Click [OK] to start the sending. The system will send all the images stored in the exam record to the storage server, meanwhile, it will send storage commitment to storage commitment server.

- To send storage commitment after an exam ends

(1) Open [Setup] (F10) → [System Preset] → [General], and then check

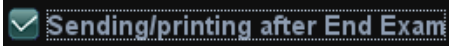

in the Extam Setup area.

(2) Set the default storage server and storage commitment server.

- a) Enter the DICOM Service Preset screen via "[Setup] (F10) → [DICOM Preset] → [Set DICOM Service]".
- b) Select a server in the Service List of Storage page and Storage Commitment page and click [Default]; you can see "Y" is marked in the Default column.
- c) Click [Exit] to exit the page and return to Setup menu, then click [Save] on the Setup menu to make the preset to take effect.

(3) When finished the presets, you can perform image scanning, each time you press <End Exam> on the control panel, the system will send the image to the default DICOM storage server for storage and send storage commitment to storage commitment server.

If images are successfully sent to the storage server, the storage commitment server will return information about the successful image storage. In the iStation screen, you will see

there is a tick "√" marked in the list below .

Tips:

Storage commitment is confined to the whole exam; not each image sending can be indicated.

NOTE:	Multi-frame storage is not allowed if "Allow Multiframe" is not selected ([Setup] → [DICOM Preset] → [Set DICOM Service] → "Storage"). For example, if there is multi-frame file in the exam to be sent, then only single-frame image storage will be performed, and after the storage is completed, there is no "√" marked in the list below  in the iStation screen.
--------------	---

11.3.6 Query/Retrieve

The query/retrieve function is employed to query and retrieve the patient exam records in a designated server.

After setting the DICOM query/retrieve server, you can perform the query/retrieve function in iStation screen.

1. Open iStation screen: press <iStation> on the control panel; or, press <Info> on the control panel, and then click [iStation] on the Patient Info screen.
2. Click [Query/Retrieve] to open the screen, or tap [Query/Retrieve] on the touch screen.

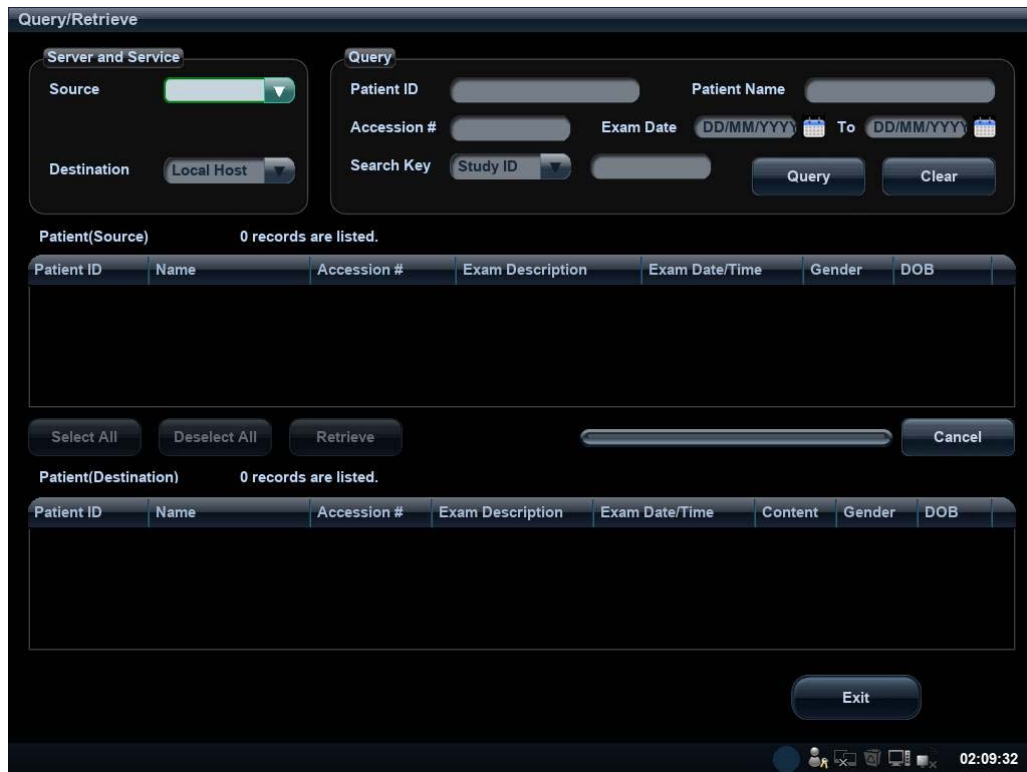

3. Select the server in “Server and Service” area (both the source and the destination).
4. Enter the query information, such as Patient ID, Patient Name, Accession #, Exam Date, or key words.
Click [Clear] to empty the entered query information.
5. Click [Query], the system performs the query and lists out the results into the patient (source) list.
You can perform further query basing on the results by entering new query information.
6. Select one or more patient records according to the actual situation.
Click [Select All] to select all the patient records in the list.
Click [Deselect All] to deselect all the patient records in the list.
7. Click [Retrieve] to retrieve the patient records in the DICOM query/retrieve server into the local machine.
8. Click [Exit], you can see the retrieved patient records are listed in the iStation screen.

11.4 DICOM Media Storage

Patient data in the ultrasound system can be saved into the external media in the format of DCM; meanwhile, DCM files can be accessed in the ultrasound system.

Media Storage

1. Select a patient record in the iStation screen.
2. Click [Send] in the popped up menu to open the dialogue box.
3. Select destination media, compression mode and size from DICOMDIR.
4. Set whether to remove the patient data from local hard disk after backup (remove exams or just remove the images).
5. Click [OK].

There should be no DICOMDIR/DCMIMG/IHE_PDI files in the external storage media of the same name with the one being backed up; otherwise, the backup can't be preceded. Besides, make sure there is enough storage space; otherwise, the backup may fail due to space shortage.

Data Restore

After DICOM format data are saved to external media, you can restore the data to the ultrasound system.

1. Review the data stored in the external media.
2. Select the data in iStation screen to be restored.
3. Click [Restore] in the iStation screen. If the data to be restored already existed in the system, the system will ask whether to overwrite the data or not.
4. After the data are restored, you can see they are listed out in the iStation screen.

NOTE: Only the system accessible media can be selected.
--

DICOMDIR Update

Data can be recorded to the disc which has backup data and free space.

11.5 Structured Report

DICOM OB/GYN Structured report, Cardiac Structured report, Vascular Structured report and Breast Structured report are supported by this system, they can be sent together with the exam only.

- Send image and structured report for storage in iStation screen
 - (1) Select "Attach SR When Store Images" in the DICOM Storage preset page, for details; please refer to "11.1.3.1 Storage Service Preset".
 - (2) Create new patient information or load scheduled the patient information.
 - (3) Perform measurements.
 - (4) Save the image (s).
 - (5) End the exam.
 - (6) Open the iStation screen, select the patient exam, and click the corresponding [Send Exam] button in the popped up menu to open the Send To dialogue box.
 - (7) Click to select "DICOM" in the Target box on the left side, and then select the DICOM storage server in the Storage Server box on the right side.
 - (8) Click [OK], you can check for the result in the DICOM Task Management dialogue box. After successful storage of both image and structured report, you can see the storage commitment mark "√" in the list below  in the iStation screen.

The structured report can be sent automatically, for details, please refer to "11.3.1 DICOM Storage".

- Back up structured report

When record or store the exam that has a structured report to the external media (DICOMDIR), the structured report can be backed up together.

11.6 DICOM Task Management

DICOM Task Management is used to view task progress or manage tasks after sending images for storage, printing, or media storage. For details, please refer to "10.8 Patient Task Management".

12 Setup

The Setup function is designed to set the configuration parameters of operating the system and maintaining user workflow setup data. The setup data of the user and system are stored to the hard drive, and should be backed up to CD/DVD or USB memory devices.

 **CAUTION:** When the preset data is changed, be sure to save the preset data according to the methods described in this chapter. Mindray is not responsible for the loss of the preset data.

- To enter Setup:
 - Press the <F10> key on the keyboard to enter setup menu.
- To exit Setup:

Select [Save] on the Setup menu, and parameter settings is saved.

Select [Cancel] on the Setup menu or press <Esc> to close the Setup menu.

When you change the system language and click [Save] on the Setup menu, the system will automatically shut down to make the modification effective.
- Basic operations

The commonly-used setting types are:

 - Text box: posit the cursor into the corresponding field box; enter the desired value through keyboard.
 - Radio button: click the button to select an item.
 - Check box: click the check box to select one or several options.
 - Drop-down list: click the arrow beside the list to select an item.

12.1 System Preset

The system enters System Preset screen automatically after you enter Setup.

Page	Description
Region	To set the hospital name, language, time zone, time format and system date/time.
General	To set patient information, exam setup, patient management, storage, system dormancy, display, operation log and so on.
Image	To set general parameters in imaging modes.
Application	To set the measure ruler, measure setting, follicle method, comment setting and so on.
OB	To set the relevant information about fetal gestational age, fetal growth formula and fetal weight.
Key Config	To assign functions to footswitch and the user-defined keys.
Admin	To set the user account control relevant information.

12.1.1 Region

Open the Region page via [Setup]→[System Preset]→[Region].

Item	Description
Hospital Information	To set the hospital relevant information like name, address, telephone and so on.
Language	To select a language for the system.
Time Zone	To select the time zone.
Time Format	To select the time format.
Date Format	To set the date format.
System Date	To set the date for the system. Posit the cursor into the “System Date” field, and enter the data through the keyboard; or, click the icon  to select the date.
System Time	Move the cursor onto the corresponding field, enter the time manually through the keyboard; or, move the cursor onto the time segment and press <Set>, then increase or decrease the certain value by rotating the multifunctional knob or clicking the icons at the right side.

12.1.2 General

Open the page via [Setup] → [System Preset] → [General].

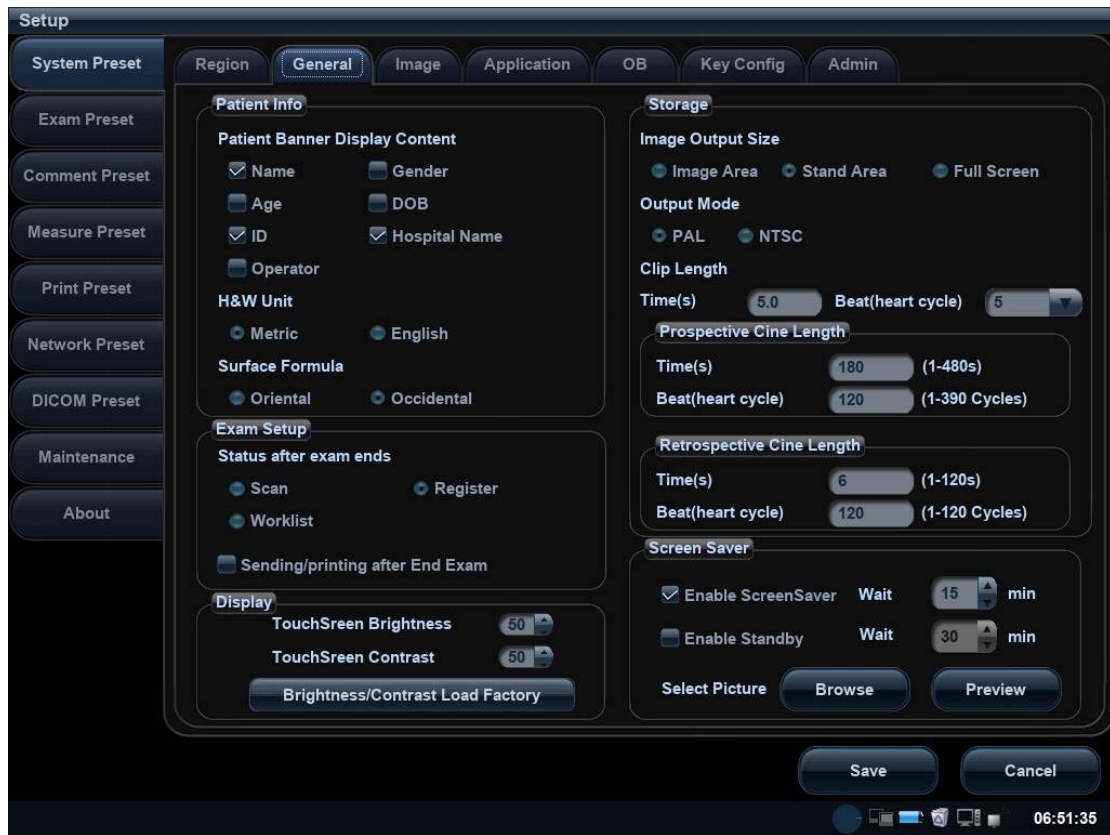

Type	Item	Description
Patient Info	Info displays in image banner	To select if to display the available patient information items on the screen.
	H&W Unit	To set the unit for patient height and weight.
	Surface Formula	To set the surface formula.
Exam Setup	Status after exam ends	To set the system status when exam ends.
Patient Management	Sending/printing after End Exam	Select if to automatically archive the exam data to DICOM server for storage/print.
Storage	Image size	To set the size for a stored image.
	Output Mode	To set the output format.
	Clip Length	To set the cine length and heart cycle.
	Prospective Cine Length	To set the cine length for prospective live capture.
	Retrospective Cine Length	To set the cine length for retrospective live capture.
Display	TouchScreen brightness/Contrast	To set the touch screen brightness and the contrast from 0 to 100.

Type	Item	Description
	Brightness/Contrast Load Factory	To set if use the factory setting values of brightness and contrast.
Screen Saver	Screen Saver	To select a system dormancy type. After screen saver function is enabled, click [Browse] to select the figure used for screen saver, and click [Preview] to see the effect. To set the waiting time before the system enters dormancy/standby status in the drop-down list beside "Wait".

12.1.3 Image Preset

Open the page via [Setup] → [System Preset] → [Image].

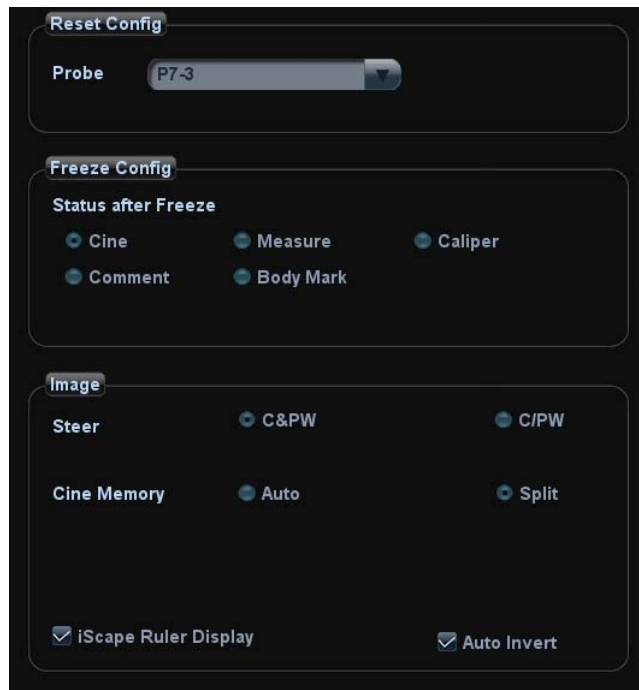

Type	Item	Description
Reset Config	Probe	To set the default probe model for the system.
Freeze Config	Status after Freeze	To set the system status after image is frozen.
Image	Steer	To set the steer mode in B+ Color +PW imaging mode. C&PW: select to adjust the sample volume in color mode and sample line in PW mode together. C/PW: select to adjust the sample volume in color mode and sample line in PW mode individually.
	Auto Invert	The spectrum can automatically invert when the color flow is steered to a certain angle, thus accommodating operator's habit of distinguishing flow direction.

Type	Item	Description
	Cine Memory	To set the cine memory splitting type.
	iScape Ruler Display	To set if to display the iScape ruler on iScape imaging mode.

12.1.4 Application

Open the page via [Setup] → [System Preset] → [Application]. Through the page, you can set the measure ruler and relevant information. For details, please refer to the Operator's Manual [Advanced Volume].

12.1.5 OB Preset

Open the page via "[Setup] → [System Preset] → [OB]". Through the page, you can set the gestational age formula, fetal growth formula, fetal weight formula and the relevant information. For details, please refer to the Operator's Manual [Advanced Volume].

12.1.6 Key Configuration

Open the page via "[Setup] → [System Preset] → [Key Config]".



■ Key function setting

You can set the functions for <Print>, <Save>, F3, F4, F5, F6, F9 and P1.

To assign a function to a key:

- (1) Click to select the desired key in the Key Function column at the left side of the page.
- (2) Click to select a function in Function area. You can see the available functions selected at the right side.
- (3) Click [Save] to complete function setting.

- Footswitch function setting

You can assign a function to the left/mid/right key of footswitch. Setting method is similar to key function setting, please refer to the above steps for setting.

- Other Settings

Item	Description
Key Brightness	To set the brightness for the keys.
Key Volume	To set the key volume, 0 means no sound.
Trackball Speed	To set the trackball speed when moving the trackball.

12.1.7 Admin

Open the page via “[Setup] → [System Preset] → [Admin].

For details of access control, please refer to “10.9 Administration”.

12.2 Exam Preset

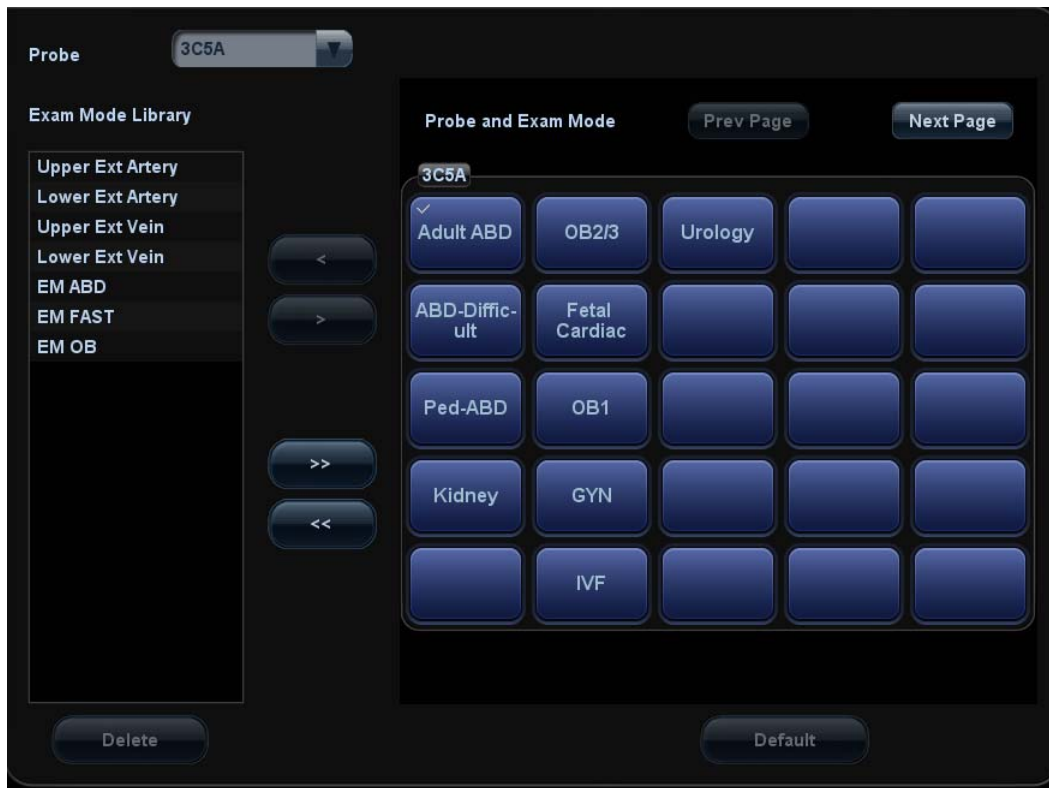

Open “[Setup]→[Exam Preset]” to enter the following screen.



You can assign available exam modes for probes.

1. To select a probe, move the cursor onto the Probe column, and select the probe model through the drop-down list.
2. Select/delete exam modes:

On the right side of the screen, you can view the current exam modes supported by the probe. On the left side, you can view all the available exam modes in the exam library for the probe.

- Select the exam from the Exam Library on the left and click  to add it to the Exam Selected.
- Click  to add the exams, which Exam Library has but Exam Selected doesn't have, from Exam Library to Exam Selected.
- To delete an exam supported by the current probe, select the exam first, and then click  to delete it.
- Click [Delete] to delete the user-defined exam mode.
- Click [Default] to set a selected exam mode as the default exam mode, and the default exam mode is moved up to the first.

12.3 Measure Preset

For details about Measure Preset, please refer to the [Advanced Volume].

12.4 Print Preset

The settings of a printer include print service and print driver.

For details about print service and printer installation, please refer to “3.6.3 Graph /Text printer” chapter.

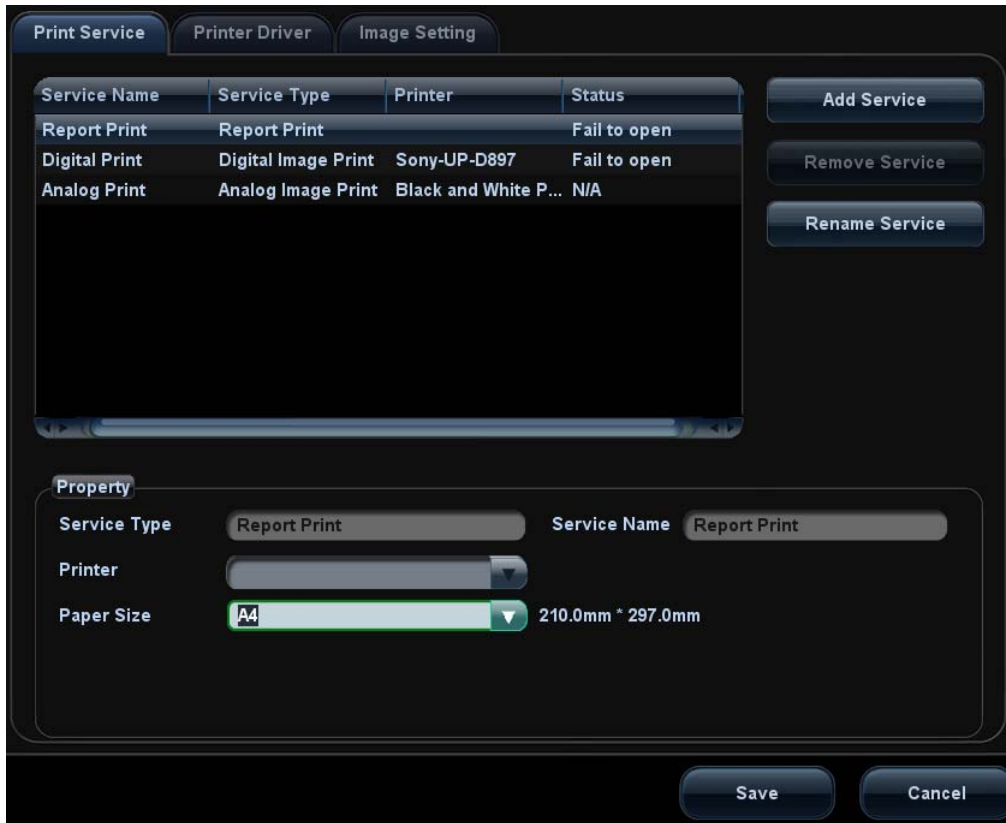

■ Print Service Setting

- Add Service: click to begin print service adding.
- Remove Service: click to delete the selected print service.
- Rename Service: click to rename the selected print service.
- Property: to preset the property of print services.

■ Printer Driver Setting

Printers listed in the operator’s manual are all supported by the system, no drive is required.

Click [Printer Driver] page to enter printer driver setting screen:

- Display the printer name as well as print status.
- You can add printer including network printer.
- Click [Printer Attribute] to see the attributes of the printer, ppd. file source path, and you can select to update the ppd. file.

For details about DICOM print, please refer to “11 DICOM”.

■ Image Settings

You can set brightness, contrast and saturation of image printing, or you can use the default value.

12.5 Network Preset

12.5.1 Local TCP/IP

NOTE DO Not edit IP address in Network Preset page as the network task is executed, otherwise it fails. View if there is any undergoing task in task manager of the system.

This page is used for setting network property of the ultrasound system, which is also applicable for DICOM function.

Open the page via “[Setup]→[Network Preset]”.

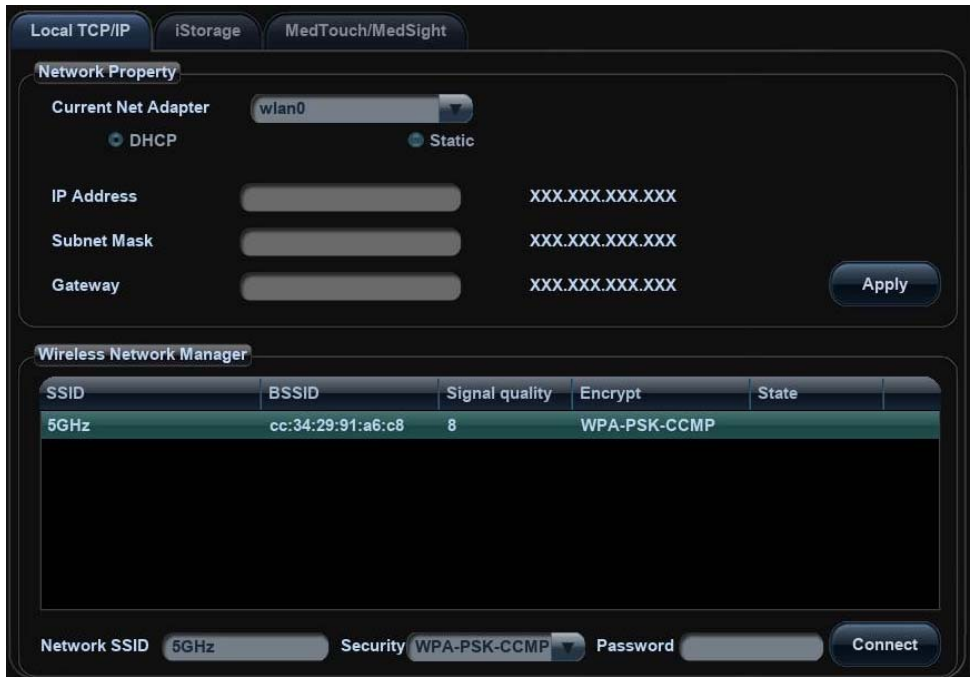

Local TCP/IP setting items are described as follows:

Name	Description
Current Network Adapter	To choose the local connection or wireless adapter.
DHCP/ Static	DHCP/Static: If “DHCP” is selected, IP address will be automatically obtained from DNS server; if “Static” is selected (using static IP address), you need to enter the IP address.
IP Address	IP Address: IP address of the system should be at the same network segment with the service IP address.
Subnet Mask	Used to set different network segment.
Gateway	Used to set the gateway IP.
Apply	Click to make the settings effective.

Note: The IP address of the system should not be occupied by other devices in the LAN, otherwise DICOM function will fail.

■ Wireless LAN

⚠ WARNING

1. It is prohibited to use the wireless LAN function in airplane, as it may violate the relevant provisions in the aviation regulations.
2. Use the wireless LAN function prudently in the emergency ambulance (or other vehicles) as other devices or communication signals may be interfered with.
3. Be prudent to use the wireless LAN function in OR/ ICU/ CCU as it may interfere with other devices.
4. When wireless LAN function is turned on, the ultrasound system may be interfered with by other equipment, even if that other equipment complies with CISPR EMISSION requirements.

■ To Use the W-LAN Function

The system can be configured with built-in wireless net adapter, so as to assist information communication.

1. Press <Setup> to enter the Setup menu.
2. Enter [Network Preset] → [Local TCP/IP].
3. Select the wireless net adapter from the [Current Net Adapter] list, and the hotspots being searched by the system are listed in the [Wireless Network Manager] box.

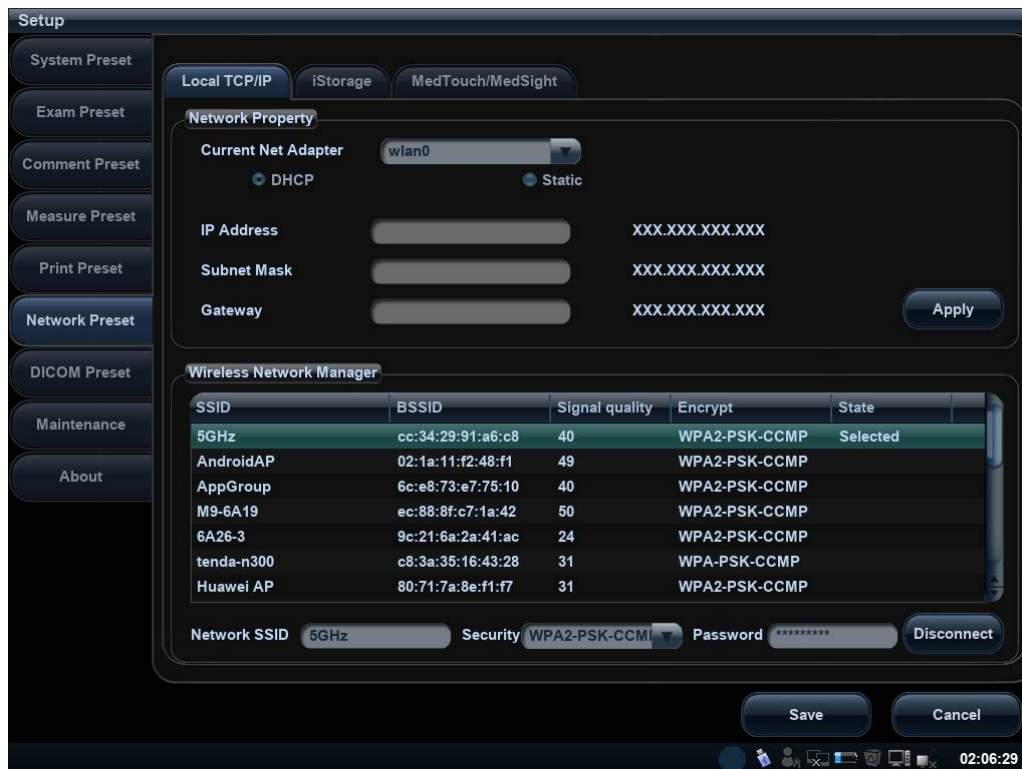



Tips: Usually the DHCP is selected. If you select Static, please refer to 12.5.1 Local TCP/IP to set IP Address, Subnet Mask and Gateway.

4. Select the desired hotspot from the [Wireless Network Manager].

The data display in the [Network SSID] and [Security] control. If the hotspot wanted is not in the list, you can input the data manually in the controls and click [Connect].

When connecting an encrypted network, enter the password in the box on the left first.

5. If the connection is successful, the  will be displayed on the lower right corner of the screen.
6. If the user wants to disconnect the WiFi. Choose the selected address from Wireless Network Manager, and click [Disconnect] to disconnect the WiFi. The selected WiFi is disabled.

- NOTE:**
1. You can refresh the W-LAN network by switching the current adapter.
 2. If the IP address displays as 0.0.0.0, this means that the network is abnormal, the reason may be failure disconnection or the system cannot obtain IP address.
 3. IF the WiFi module is not installed, the network manager icon appears , and reminds of the failure of the WiFi network connection. The icon disappears soon.

12.5.2 iStorage

Enter [Preset]→[Network Preset]→[iStorage].

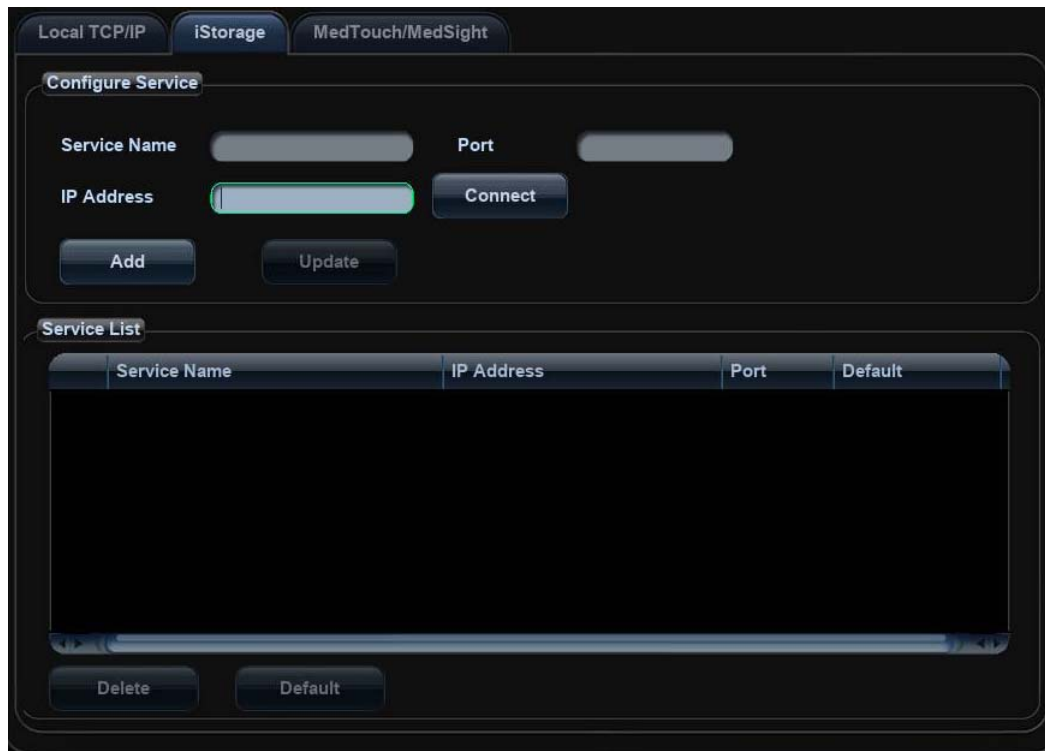

Name	Description
Service Name	Name of the device, cannot be empty
IP Address	IP address of the PC installed with iStorage software, cannot be empty
Connect	Press to verify connection with the PC server. On PC server, if the storage path has not been confirmed, a dialog box will pop up and guide the user to set it. If the storage path on PC has already been set, here it displays connection successful after clicking this button.
Add	Click it to add the new service to the service list.
Update	To save the changed parameters.
Delete	Click to delete the selected service in the service list.
Default	Click to set an selected item in the list as the default iStorage server.

■ Add a network service:

1. Set the network server properties as described above.
2. Click [Add] to add the service to the Service list;
3. Select the added service in the service list, you can delete it.

■ Modify a network service:

1. Select the service to be updated in the service list.
2. You can see properties in the Configure Service area.
3. Modify the parameters and click [Update] to update setting.

Tips: in order to make network storage function normally, setting of the sharing folder of the PC server in advance is a must, e.g. machine name, IP address, should be confirmed at first.

12.5.3 MedTouch/MedSight Preset

You can set environment for MedTouch/MedSight here and then use the MedTouch/MedSight function by mobile phone or tablet computers. See MedTouch/MedSight manual for details.

12.6 Maintenance

In the Setup menu, select [Maintenance] enter the screen. If you require other maintenance functions, please contact Mindray Customer Service Department or sales representative.

12.6.1 Option

The system enters Option page after you enter the Maintenance screen. In Option list, the system lists out all the system supported options and the installation status (Disabled or Installed).

■ Install and uninstall

- Click [Install] to begin the installation of a disabled option.
- Click [Uninstall] to begin the un-installation of an already installed option.

■ Trial

Select the option item in the list to see the information on the Comment region on the right.

For functions that are not configured, you can use the function for free for 90 days.

- Click to select the function(s) and click [Trial].

Tips: every trial option can be used only once.

Please contact Mindray Customer Service Department or sales representative for details.

12.6.2 Other Settings

Type	Item	Description
Log	Export Log	Export the operation log.
Preset Manager	Export	Export preset data to disk.
	Import	Import the preset data into the system.
	Load Factory	Local factory default settings.
	Export Image Preset	Export the preset image data.
	Import Image Preset	Import the preset image data.

12.7 System Information

Click [About] in the Setup menu to enter the system information screen.



This screen displays the system software version and versions of other devices. You cannot edit the information but only view them. The information varies depending upon the system configurations and version.

13 Probes and Biopsy

Note: For details of storage time and condition for disinfected probes or sterilized probes and brackets, please refer to Technical standard for Disinfection of Medical and Health Structures.

13.1 Probe

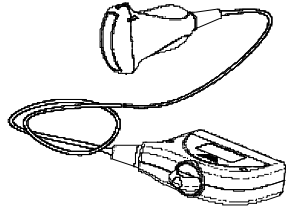
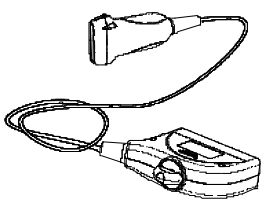
The system supports the following probes:

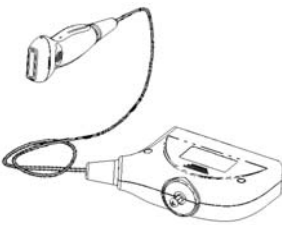
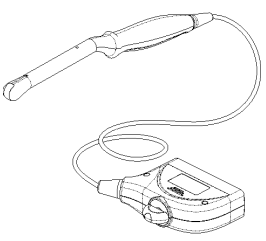
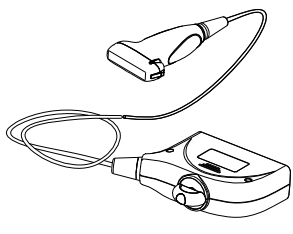
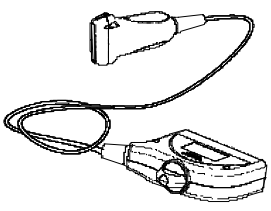
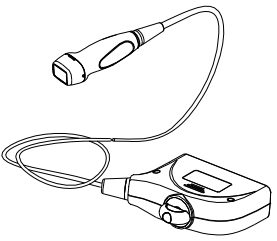
Probe Model	Illustration	Probe Model	Illustration
3C5A		7L4A	
6C2		L14-6	
V10-4B		7L5	
L7-3		P7-3	

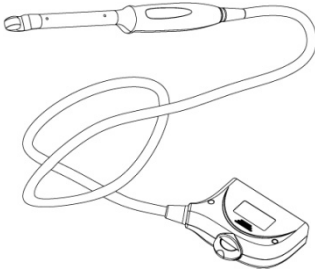
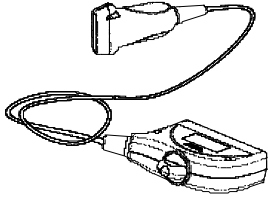
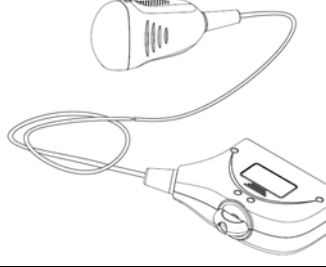
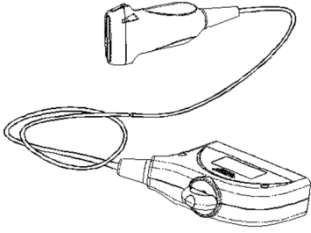
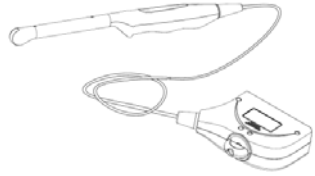
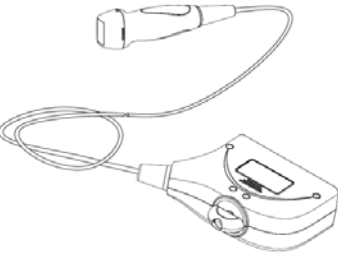
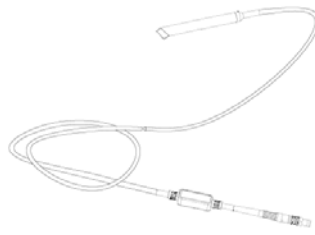
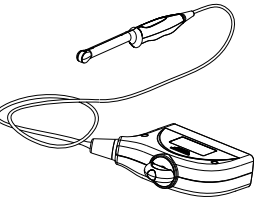
Probe Model	Illustration	Probe Model	Illustration
CB10-4E		L12-3E	
D7-2E		L14-6NE	
V11-3		P4-2	
CW5s		V10-4	

13.1.1 Name and Function of Each Part of the Probe

The basic structures and corresponding functions of probes are basically the same; the following will take probe 3C5A as an example.

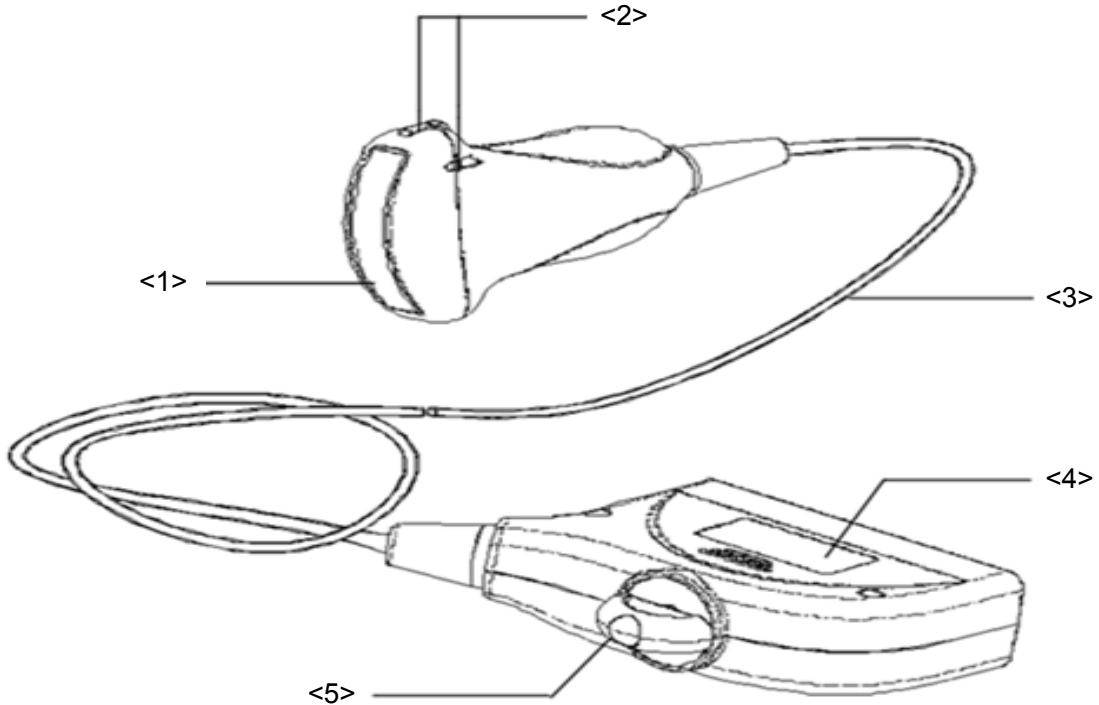

No.	Name	Function
<1>	Probe head	It converts the electrical signal into ultrasound signal, making the sound beams focus in the given direction; meanwhile, it will receive the ultrasound signal and then convert the received signal into electrical signal. The lens on the surface is the acoustic lens. Apply ultrasound gel on the acoustic lens.
<2>	Needle-guided bracket fix tabs and grooves	Used to mount the needle-guided bracket.
<3>	Probe cable	Used to transmit electrical signals between the probe body and connector.
<4>	Probe connector	Used to connect the probe to the ultrasonic diagnostic system.
<5>	Lock handle	Used to lock the connector to the ultrasonic diagnostic system.

Tips:

The probes' structure marked <2> in the figure above may vary with the matched needle-guided brackets.

13.1.2 Orientation of the Ultrasound Image and the Probe Head

The orientation of the ultrasound image and the probe are shown as below. The “Mark” side of the ultrasound image on the monitor corresponds to the mark side of the probe. Check the orientation before the examination (Here takes linear probe as an example).

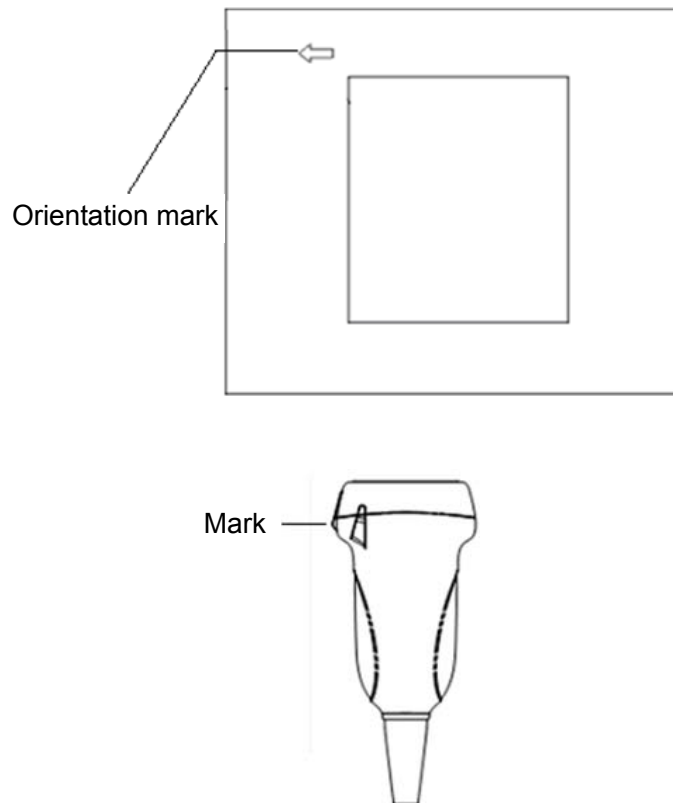

13.1.3 Procedures for Operating

This section describes general procedures for operating the probe. The proper clinical technique to be used for operating the probe should be selected on the basis of specialized training and clinical experience.

■ Procedures for operating (with biopsy function):

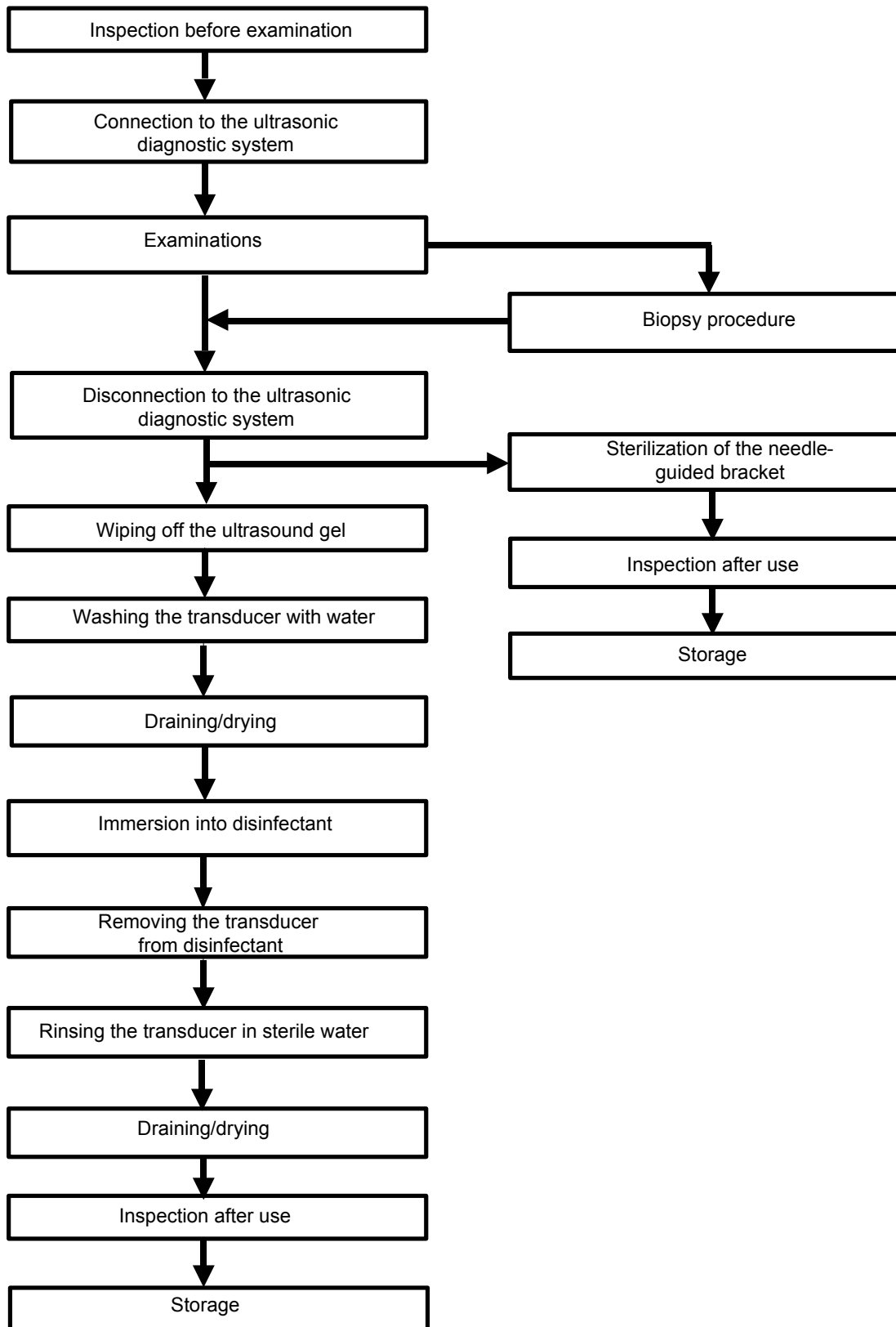

■ Procedures for operating (with no biopsy function):

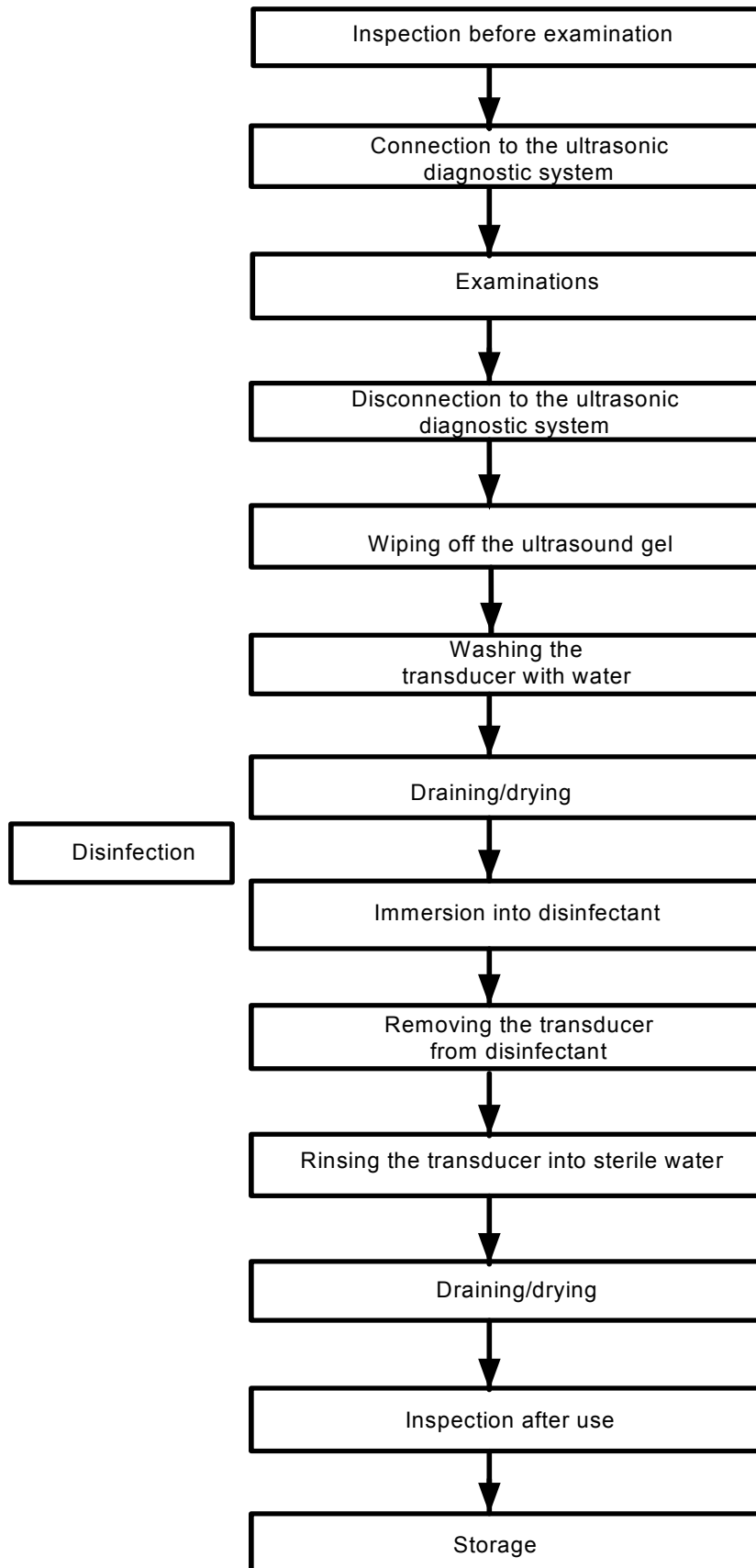

⚠ WARNING: Disinfect the probe and sterilize the needle-guided bracket before and after an ultrasound-guided biopsy procedure is performed. Failure to do so may cause the probe and the needle-guided bracket become source of infection.

13.1.4 Wearing the Probe Sheath

A legally marketed probe sheath must be installed over the probe before performing intra-cavitary and intra-operative examination. Protective barriers may be required to minimize disease transmission. Probe sheaths are available for use with all clinical situations where infection is a concern.

To order probe sheath, contact:

CIVCO Medical Instruments Co.

102 First Street South, Kalona, IA 52247-9589 USA Tel: 1-319-656-4447

E-mail: info@civco.com

<http://www.civco.com>

⚠ CAUTION:

1. Be sure to cover the probe with a new (unused) probe sheath to prevent infection during examination. If the package of a probe sheath is open or broken, the sterilization of the probe sheath may not be sufficient. **DO NOT** use such a probe sheath.
2. The cover contains natural rubber latex and talc that can cause allergic reactions in some individuals.
3. **DO NOT** use an expired probe sheath. Before using probe sheaths, verify whether the term of validity has expired.

Method (for reference only):

1. Place an appropriate amount of gel inside the sheath or on probe face. Poor imaging may result if no gel is used.
2. Insert the probe into the sheath; make sure to use proper sterile technique. Pull cover tightly over probe face to remove wrinkles and air bubbles, taking care to avoid puncturing cover.

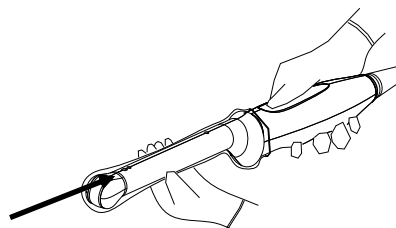
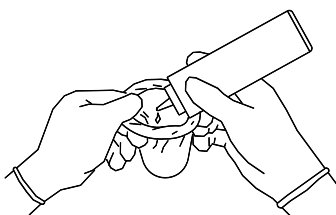

3. Secure the sheath with enclosed elastic bands.
4. Inspect the sheath to ensure there are no holes or tears.

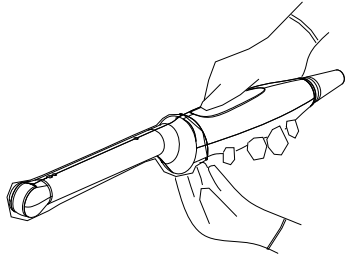

13.1.5 Probes Cleaning and Disinfection

After completing each examination, clean and disinfect (or sterilize) the probes as required. When biopsy procedures have been performed, be sure to sterilize the needle-guided bracket. Failure to do so may result in the probe and the needle-guided bracket to becoming sources of infection. Please follow the instructions in the manual for cleaning.



WARNING:

Never immerse the probe connector into liquid such as water or disinfectant. Immersion may cause electrical shock or malfunction.



CAUTION:

1. When performing cleaning and disinfection of the probe to prevent infection, wear sterile gloves.



2. After disinfection, rinse the probe thoroughly with sterile water to remove all chemical residues. Chemical residues on the probe may be harmful to the human body.

3. No cleaning and disinfecting may result in the probe becoming a source of infection.

NOTE:

1. After the examination, wipe off the ultrasound gel thoroughly. Otherwise, the ultrasound gel may solidify and degrade the image quality of the transducer.
2. DO NOT make the probe to become overheated (more than 55°C) during cleaning and disinfections. High temperature may cause the probe to become deformed or damaged.

Cleaning

Please refer to the instructions in the manual and follow your hospital policy and procedures for cleaning.

1. Disconnect the probe from the system.
2. Wear sterile gloves to prevent infection.
3. Wash the transducer with clean water or soapy water to remove all the foreign matters, or, wipe the transducer with a soft ethyl carbamate sponge. Avoid using a brush, because it may damage the transducer.
4. Dry the transducer using a sterile cloth or gauze after rinsing. Do not dry the transducer by heating it.

Disinfecting with Sprays



CAUTION:

Use protective eyewear when disinfecting using sprays.

1. Wear sterile gloves to prevent infection.
2. After you have finished cleaning, spray the transducer with a disinfectant. Follow the disinfectant manufacturer's recommended contact time and mode.
3. Remove any residue with a water-moistened soft cloth on the transducer.
4. Wipe off water on the transducer using sterile cloth or gauze after washing.

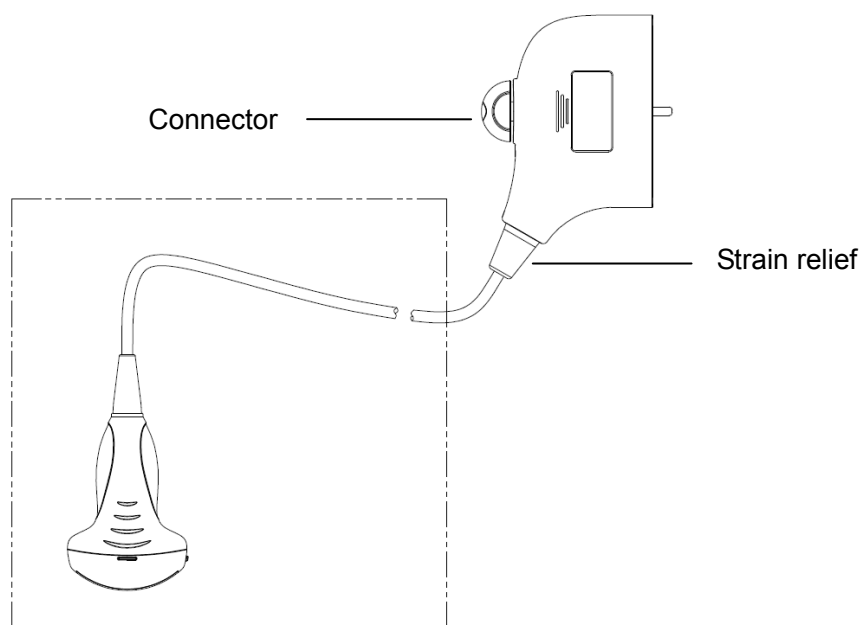

NOTE: Observe the graph here carefully to perform disinfection. Do not spray the strain relief on the connector end or the connector.

Disinfecting by Immersion

1. Wear sterile gloves to prevent infection.
2. Clean the transducer before disinfecting it. MINDRAY recommends the following solutions to disinfect the transducer.
 - Refer to the instructions provided by the chemical manufacturer concerning concentration of the disinfectant solution, method of disinfection and dilution and cautions during use. Do not soak the transducer connector or the cable near it into water or any solution.
 - Soak the transducer into the disinfectant solution for the shortest time the manufacturer recommends (for example, the shortest time recommended by the manufacturer for soaking Cidex OPA is 12 minutes).
 - Follow local regulations when selecting and using the disinfectant.
3. Rinse the transducer with plenty of sterile water (about 2 gallons) for at least 1 minute to remove all chemical residues on it. Or, follow the rinsing method recommended by the disinfectant manufacturer to rinse the transducer.
4. Wipe off the water on the transducer with sterile cloth or gauze after rinsing it. Do not dry the transducer by heating.

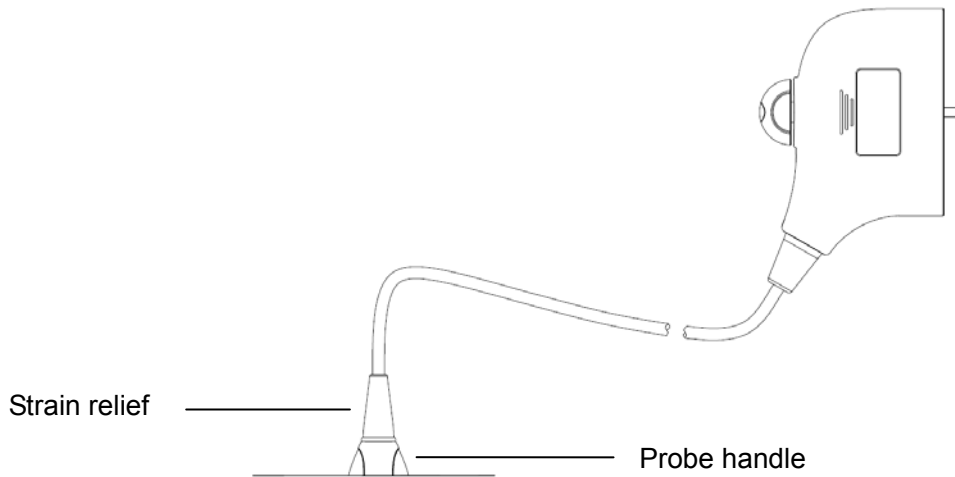

NOTE: 1. Observe the graph here carefully to immerse the transducer. Only soak parts of the transducer below the strain relief.

2. Repeated disinfection will eventually damage the probe, please check the probe performance periodically.

For the usage of each disinfectant, please refer to Disinfectant Guide.

13.1.6 Storage and Transportation

When all examinations for the day have been completed, confirm that the probe is in good condition. After disinfecting the probe, confirm that the probe is in good condition and store it in a suitable place so that the next examination can be conducted smoothly.

1. To prevent the probe from being damaged, DO NOT store it in locations where it may be exposed to:
 - Direct sunlight or X-rays
 - Sudden changes in temperature
 - Dust
 - Excessive vibration
 - Heat generators

2. Store and transport the probe under the following ambient conditions:

- Ambient temperature: -20°C ~ 55°C
- Relative humidity: 30% ~ 95% (no condensation)
- Atmospheric pressure: 700 hPa ~ 1060 hPa

Store and transport the D7-2E and D6-2NE probe under the following ambient conditions:

- Ambient temperature: -10°C ~ 60°C
- Relative humidity: 30% ~ 95% (no condensation)
- Atmospheric pressure: 700 hPa ~ 1060 hPa

3. When the probe is sent to MINDRAY Customer Service Department or sales representative for repair, be sure to disinfect it and keep it in the carrying case to prevent infection.
4. Sterilize the carrying case as necessary.

13.2 Biopsy Guide



WARNING:

1. The person performing biopsy procedures must understand diagnostic ultrasound thoroughly and have been trained adequately, otherwise, side effects may be caused to the patient.
2. In situations listed below, the biopsy needle may fail to penetrate the target. The incorrect biopsy may cause various side effects in the patient.
Use a needle-guided bracket other than that provided.
Mount the needle-guided bracket incorrectly.
Use a biopsy needle that is unsuitable for the type of biopsy being performed.
Use a biopsy needle or guiding block that is unsuitable for the needle guide.
3. Before and after a biopsy procedure is performed, confirm that the needle-guided bracket is normal. Manually confirm that the parts of the needle-guided bracket do not slip off or move from their proper positions. If the needle-guided bracket is used when parts are not securely and correctly installed, the patient may be injured. If an abnormality is found on the needle-guided bracket, immediately stop using it and contact MINDRAY Customer Service Department or sales representative.
4. DO NOT use a needle-guided bracket when scanning is performed. The needle may advance in an incorrect direction and possibly injure the patient.
Never perform a biopsy during image scanning.
5. DO NOT freeze an image while performing biopsy procedure.
6. During biopsy procedures, the needle may deviate from the desired course due to the tissue characteristics or the type of needle. In particular, needles of small diameters may deviate to a greater degree.
7. Disinfect the probe and sterilize needle-guided bracket before and after each ultrasound-guided biopsy procedure is performed. Fail to do so may cause the probe and the needle-guided bracket become sources of infection.
8. Before clean and sterilize needle-guided bracket please remove the needle-guided bracket from the probe referring to chapter 12.
9. The needle mark displayed on the ultrasound image does not indicate the actual position of the biopsy needle. Therefore, it should only be used as a reference. Always monitor the relative positions of the biopsy needle during the procedures.

10. Adjust the needle mark before the biopsy procedure is performed.
11. When performing biopsy procedures, use only sterile ultrasound gel that is certified to be safe. And manage the ultrasound gel properly to ensure that it does not become a source of infection.
12. When performing the operation concerning biopsy, wear sterile gloves.
13. Image of the biopsy target and the actual position of the biopsy needle:

Diagnostic ultrasound systems produce tomographic plane images with information of a certain thickness in the thickness direction of the probe. (That is to say, the information shown in the images consist all the information scanned in the thickness direction of the probe.) So, even though the biopsy needle appears to have penetrated the target object in the image, it may not actually have done so. When the target for biopsy is small, dispersion of the ultrasound beam may lead to image deviate from the actual position. Pay attention to this.

If the target object and the biopsy needle appear in the image as shown in the figures below (For reference only):

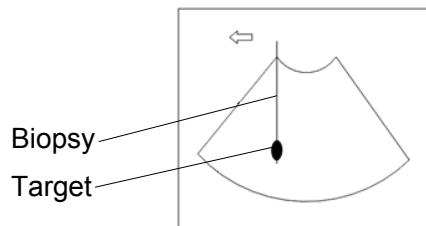

The biopsy needle appears to reach the target object in the image

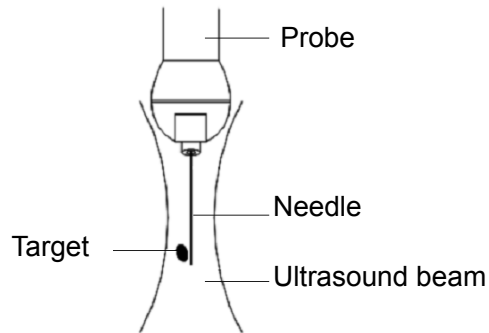

Dispersion of the ultrasound beam

The biopsy needle may not have actually entered the target object even though it appears to have done so on the image. To avoid this problem, note points below:

Do not rely only on the needle tip on the image. Pay careful attention to that, when the biopsy needle comes into the target object or contacts with it, the object should shift slightly.

Before you perform the biopsy, please evaluate the size of the object and confirm if the biopsy can be carried out.

13.2.1 Basic Procedures for Biopsy Guiding

1. Select the right needle-guided bracket and needle, install them properly. For details, please refer to 13.2.3 Needle-guided Bracket Inspection and Installation”.
2. Verify the biopsy guide line.
3. Press <Biopsy> on the control panel to enter the biopsy.

Tips:

- If the current probe has no matched bracket; or, the image is frozen and the guide line is hidden before image frozen, then you can't enter Biopsy menu.
- Before entering Biopsy menu, the system will prompt you “Please verify guidelines before biopsy”.

4. Tap [Verify] to enter the Verify menu to verify the guide line. After the verification, click [Save] on the menu to save the parameter setting. And then tap [Exit].

Tips:

- If you switched the probe or needle-guided bracket during the biopsy, please verify the guide line again.
- When exit the Verify menu without saving the setting, system will confirm with you “Data have changes. Do you want to save the changes?”. Tap [OK] to save the setting and return to Biopsy menu.

5. Scan to locate the target. Center the target in the electronic guidezone path.
6. Direct the needle into the area of interest for specimen.
7. After extraction of the biopsy sample is completed, gently remove the probe from the body.

To exit Biopsy menu: press <Esc> key; or, tap [Exit] on the touch screen.

8. Disassemble the items and properly dispose of these items as required.
9. Tap [Exit] after finishing biopsy.



DANGER:

Fail to match the guidezone displayed to the guide may cause the needle to track a path outside the zone.

It is extremely important that when using the adjustable angle biopsy guides, the angle displayed on the screen matches the angle set on the guide, otherwise the needle will not follow the displayed guidezone which could result in repeated biopsies or patient injury.

13.2.2 Needle-guided Brackets

A needle-guided bracket is available for purchase as an optional accessory; it is used in combination with the probe. Some of the probes have matched needle-guided bracket and needles. To order needle-guided brackets, contact MINDRAY Customer Service Department or sales representative.

For biopsy or treatment, ultrasound-guided biopsy procedures can be performed using the probe in combination with a needle-guided bracket (optional accessory) and a biopsy needle (provided by the user).

Names of Parts

This section describes the parts and corresponding functions of each needle-guided bracket.

■ NGB-004

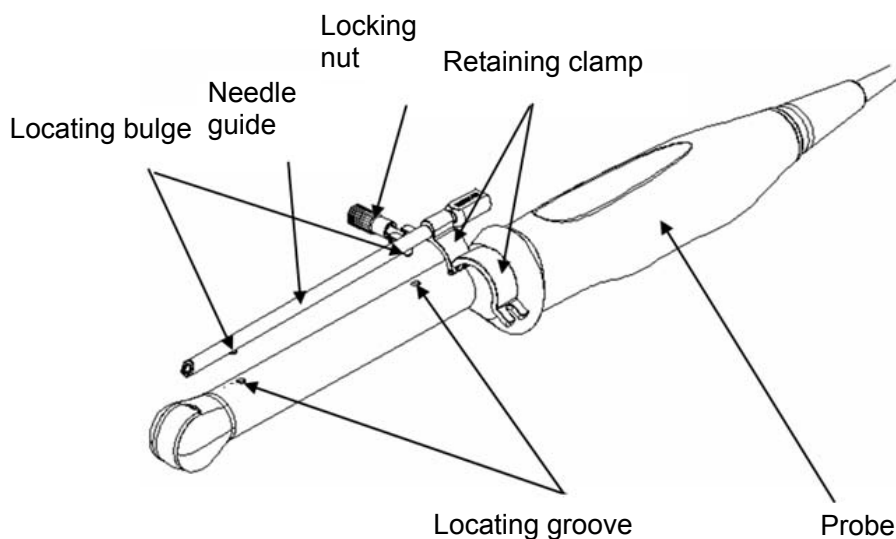

■ NGB-005

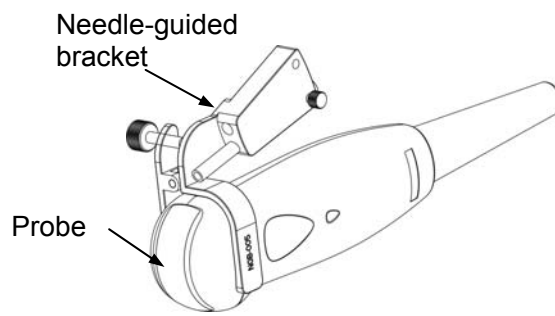
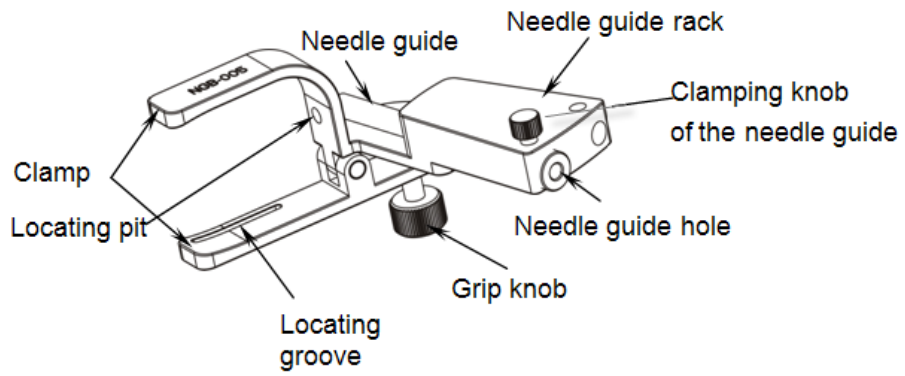

■ NGB-006

Metal/needle detachable needle-guided bracket:

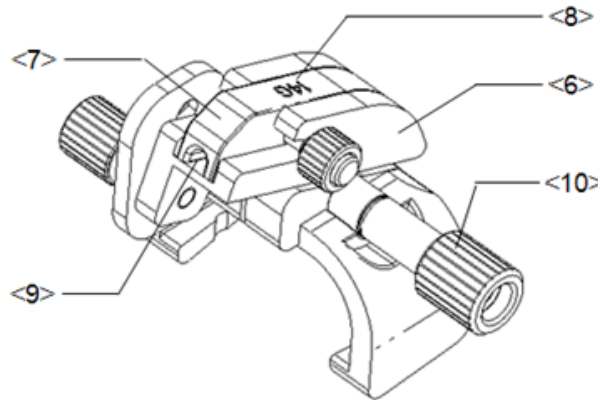

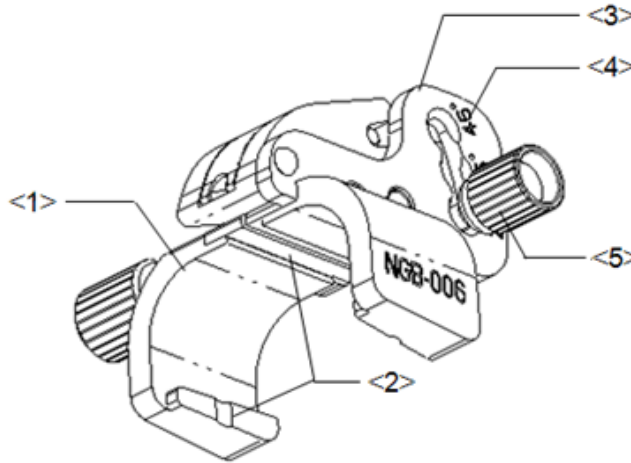

No.	Name	Description
<1>	Support of needle-guided bracket	Used for installing the needle-guided bracket on the probe.
<2>	Groove and tab of the needle-guided bracket	Respectively matched with the tab and groove of the probe.
<3>	Angle adjusting base	There are 3 types of angles available to be adjusted.
<4>	Angle shift sign (25°, 35°, 45°)	Matched with the biopsy angle (25°, 35°, 45°).
<5>	Angle pinch nut	Used for fixing the angle block at a chosen angle.
<6>	Angle block	Used for fixing the angle block at a certain angle.
<7>	Guiding block	Used for installing biopsy needle; there are five specifications of guiding blocks for different biopsy needles.
<8>	Specification of guiding block (14G)	Matched with the corresponding biopsy needle (14G).
<9>	Guiding hole of the biopsy needle	Used for installing the biopsy needle.
<10>	Pinch nut of needle-guided bracket	Used for locking the needle-guided bracket and the probe.

Plastic/needle detachable needle-guided bracket:

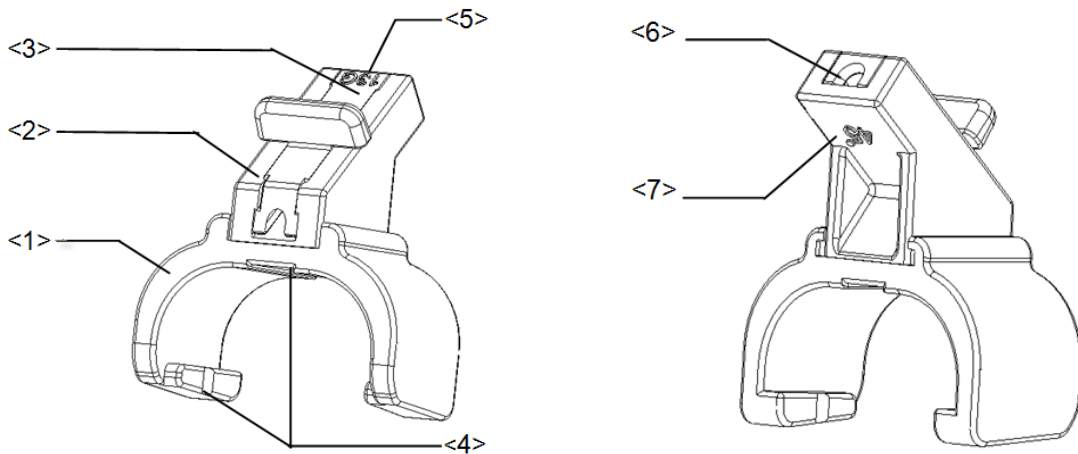

No.	Name	Description
<1>	Support of needle-guided bracket	Used for installing the needle-guided bracket on the probe.
<2>	Angle block	Used for determining the angle of the biopsy; there are three specifications of blocks of angle.
<3>	Guiding block	Used for installing biopsy needle; there are five specifications of guiding blocks for different biopsy needles.
<4>	Groove and tab of the needle-guided bracket	Respectively matches with the tab and groove of the probe.
<5>	Specification of guiding block (13G)	Matched with the corresponding biopsy needle (13G).
<6>	Guiding hole of the biopsy needle	Used for installing the biopsy needle.
<7>	Specification of angle block (45°)	The corresponding biopsy angle is 45°.

■ NGB-007

- Metal needle-guided bracket:

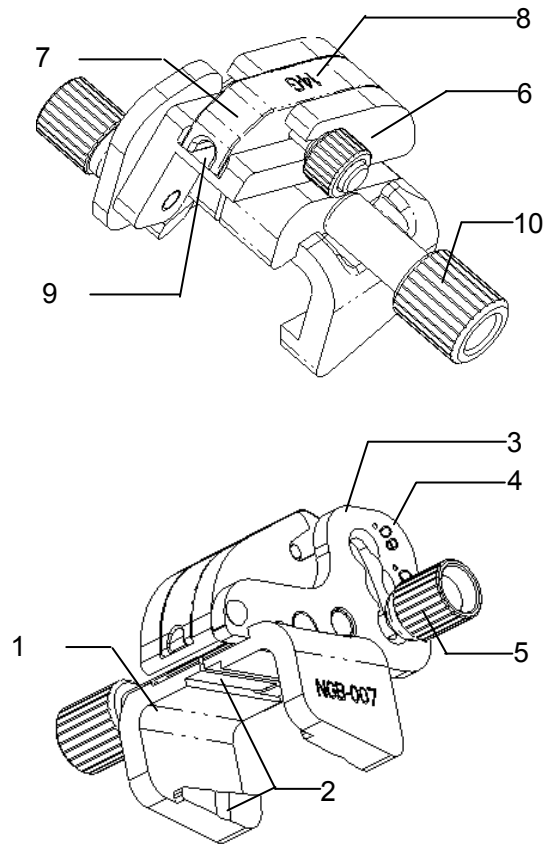

No.	Name	Description
1.	Support of needle-guided bracket	Used for installing the needle-guided bracket on the probe.
2.	Groove and tab of the needle-guided bracket	Respectively matches with the tab and groove of the probe
3.	Angle adjusting base	There are 3 types of angles available to be adjusted.
4.	Angle shift sign(40°, 50°, 60°)	Matched with the biopsy angle (40°, 50°, and 60°).
5.	Angle pinch nut	Used for fixing the angle lock at a chosen angle.
6.	Angle block	Used for determining the angle of the biopsy; different specifications of blocks can be used.
7.	Guiding block	Used for installing biopsy needle; there are five specifications of guiding blocks for different biopsy needles.
8.	Specification of guiding block (14G)	Matched with the corresponding biopsy needle (14G).
9.	Needle guide hole	Used for installing the biopsy needle.
10.	Pinch nut of needle-guided bracket	Used for locking the needle-guided bracket and the probe

- Plastic needle-guided bracket:

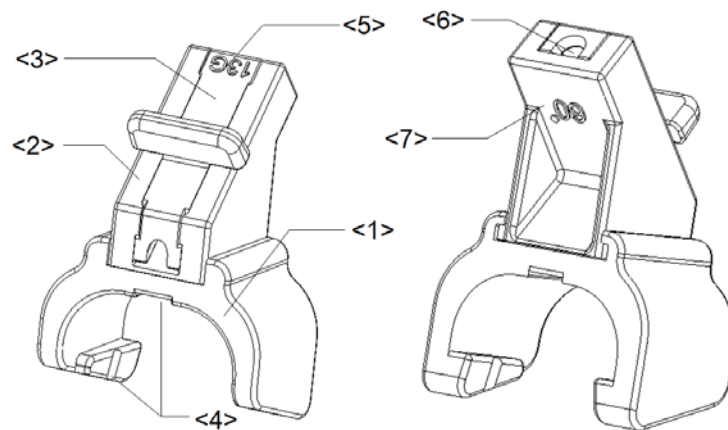

No.	Name	Description
<1>	Support of needle-guided bracket	Used for installing the needle-guided bracket on the probe.
<2>	Angle block	Used for determining the angle of the biopsy; there are three specifications of blocks of angle.
<3>	Guiding block	Used for installing biopsy needle; there are five specifications of guiding blocks for different biopsy needles.
<4>	Groove and tab of the needle-guided bracket	Respectively matched with the tab and groove of the probe.
<5>	Specification of guiding block (13G)	Matched with the corresponding biopsy needle (13G).
<6>	Needle guide hole	Used for installing the biopsy needle.
<7>	Specification of angle block (60°)	Corresponding to the size of the biopsy angle (60°).

■ NGB-011

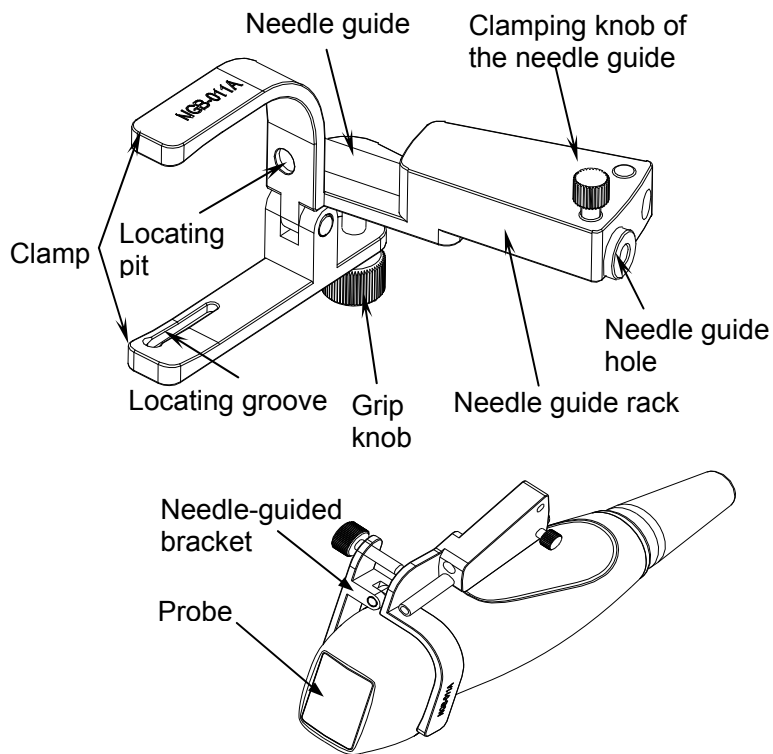

■ NGB-016

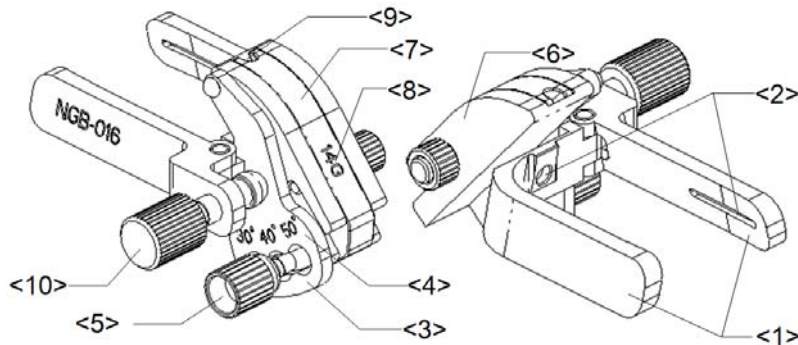

No.	Name	Description
<1>	Clamp of needle-guided bracket	Used for installing the needle-guided bracket on the probe.
<2>	Groove of the needle-guided bracket	Matches with the tab of the probe.
<3>	Angle adjusting base	There are 3 types of angles available to be adjusted.
<4>	Angle shift sign (30°, 40°, 50°)	Matches with the biopsy angle. (30°, 40°, 50°).
<5>	Angle pinch nut	Used for fixing the angle lock at a chosen angle.
<6>	Angle block	Determines the angle of the biopsy; different specifications of blocks can be used.

No.	Name	Description
<7>	Guiding block	Used for installing the needles of different specifications, 5 types of needles are available.
<8>	Specification of guiding block (14G)	Matched with the corresponding biopsy needle (14G).
<9>	Guiding hole of biopsy needle	Used for installing the needles.
<10>	Pinch nut of needle-guided bracket	Used for locking the needle-guided bracket and the probe.

13.2.3 Needle-guided Bracket Inspection and Installation

Inspection of the Needle-guided Bracket

Be sure to perform inspections before and after use of the needle-guided bracket. If an abnormality is found on the needle-guided bracket, immediately stop using it and contact MINDRAY Customer Service Department or sales representative.

1. Sterilize the needle-guided bracket before and after use.
2. Confirm that the needle-guided bracket is free of damage, deformation, stripping, and malfunction, loose or missing parts.
3. Confirm that the needle-guided bracket is securely mounted in the correct position.

Installing the Needle-guided Bracket

■ NGB-004

- (1) Put on the sterile probe sheath.

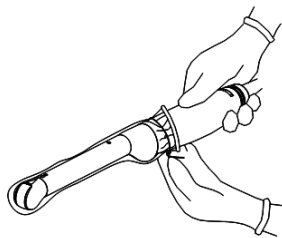

- (2) Open the retaining clamp, align the needle-guided bracket with the probe to locate the locating bulge on the needle guide to the locating grooves on the probe, and then turn the retaining clamp to match it with the probe (See the figure below).

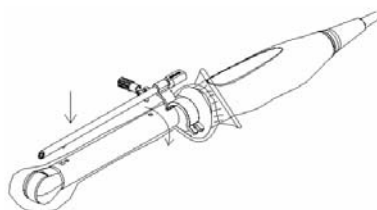

- (3) When the retaining clamp is turned to the right position, the locking nut will lock the retaining clamp and the needle-guided bracket is then mounted to the right position.

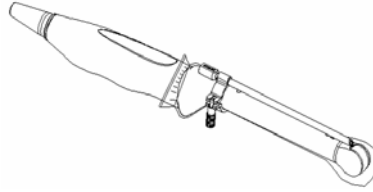

■ NGB-005

- (1) Inosculate the locating groove on the clamp with the two raised edges on the probe head and aligning the locating pit of the clamp to the convex point on the probe head.
- (2) Turn the grip knob at the tail of the needle-guided bracket tightly.

■ NGB-006

Metal needle-guided bracket:

- (1) Put on the sterile transducer cover.
- (2) Hold the transducer by one hand, select the proper needle-guided bracket, and hold it with the other hand. Match the groove and tab with the tab and groove of the transducer respectively. Amount the bracket onto the transducer.



- (3) Turn the pinch nut to secure the bracket and the transducer.
- (4) Select a guiding block of proper size, slightly push it into the groove on the support.



- (5) Screw the nut on the guiding block to secure the block and the needle-guided bracket.
- (6) Insert a biopsy needle with the same specification as that of the guiding block into the hole of the guiding block.

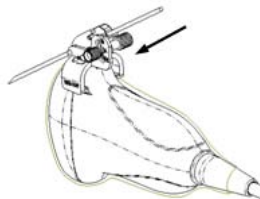

Plastic needle-guided bracket:

- (1) Put on the sterile probe sheath.

- (2) Hold the probe by one hand, select proper needle-guided bracket, and hold it with the other hand. Align the narrow end tab of the needle-guided bracket with the groove of the probe, then push the needle-guided bracket forward, making the tabs and the grooves of the needle-guided bracket to match with the grooves and tabs of the probe.



- (3) Check manually to confirm that the needle-guided bracket is securely installed on the probe.
- (4) Select a proper guiding block and push it into the groove above the angle block, and clamp it tightly.

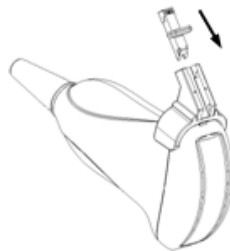

- (5) Insert a biopsy needle with the same specification as that of the guiding block into the hole of the guiding block.

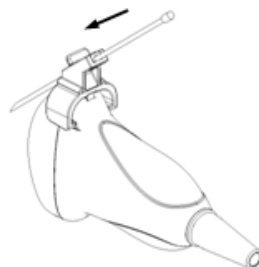

■ NGB-007

Metal needle-guided bracket:

- (1) Put on the sterile probe sheath.
- (2) Select a proper needle-guided bracket, and match the groove and tab with the tab and groove of the probe respectively. Mount the bracket onto the probe.

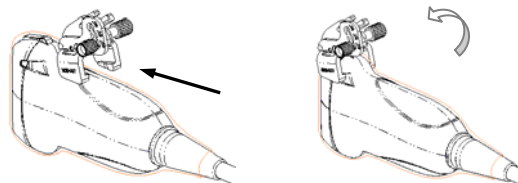

- (3) Screw the pinch nut of the needle-guided bracket to confirm that the needle-guided bracket is properly installed on the probe.
- (4) Select a proper guiding block and push it into the groove above the angle block, and clamp it tightly.

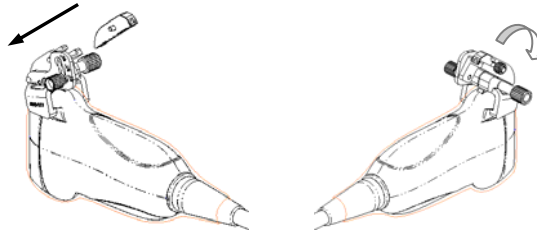

- (5) Screw the nut of the block to secure the block.
- (6) Insert a biopsy needle with the same specification as that of the guiding block into the hole of the guiding block.

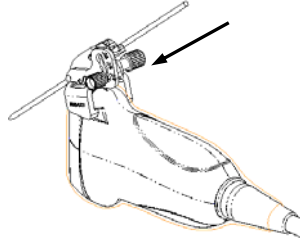

Plastic needle-guided bracket:

- (1) Put on the sterile probe sheath.
- (2) Hold the probe by one hand, select the proper needle-guided bracket, and hold it with the other hand. Align the narrow end tab of the needle-guided bracket with the groove of the probe, then push the needle-guided bracket forward, making the tabs and the grooves of the needle-guided bracket to match with the grooves and tabs of the probe.

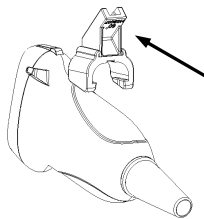

- (3) Check manually to confirm that the needle-guided bracket is securely installed on the probe.
- (4) Select a proper guiding block and push it into the groove above the angle block, and clamp it tightly.

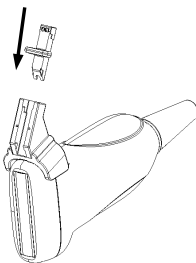

- (5) Insert a biopsy needle with the same specification as that of the guiding block into the hole of the guiding block.

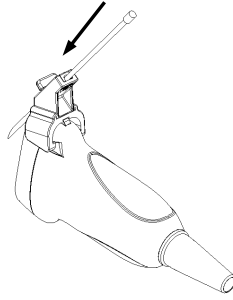

■ NGB-011

- (1) Inoculate the locating groove on the clamp with the two raised edges on the probe head and align the locating pit of the clamp to the convex point on the probe head.
- (2) Turn the grip knob at the tail of the needle-guided bracket tightly.

■ NGB-016

- (1) Put on the probe sheath.
- (2) Select a proper needle-guided bracket, and match the groove with the tab of the probe. Mount the bracket onto the probe.

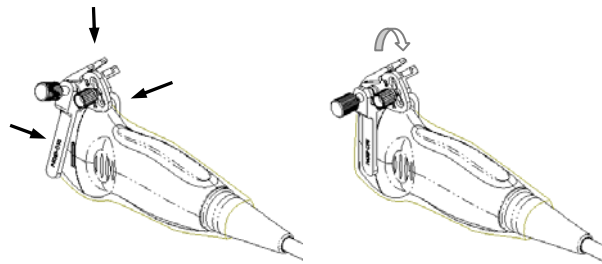

- (3) Screw the pinch nut of the needle-guided bracket to confirm that the needle-guided bracket is properly installed on the probe.
- (4) Select the appropriate guiding block, and fit it into the groove on the angle block.

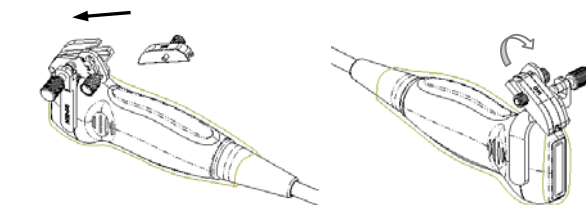

- (5) Screw the nut on the guiding block to secure the guiding block with the needle-guided bracket.
- (6) Insert the needle of the same specification with that of the guiding block into the guiding hole.

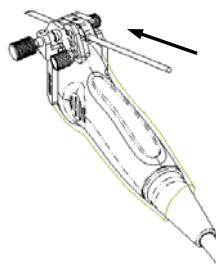



CAUTION: Ensure that all guide parts are seated properly prior to performing a biopsy.

13.2.4 Verifying the Biopsy Guide Line

Adjusting the needle mark is necessary before every biopsy procedure.

1. Confirm that the needle-guided bracket has been installed securely in the correct position.
2. Prepare a container filled with sterile water.
3. Place the head of the probe in the sterile water, and get a biopsy needle into the needle guide.
4. When the biopsy needle appears on the image, confirm that the biopsy needle is displayed at almost the same position as the selected needle mark.



WARNING:

1. Prior to each biopsy procedure, be sure to verify the guide line.
2. If the needle is not consistent with the guide line, DO NOT perform the biopsy procedure.

NOTE: You can perform guide line verification on a single live B/C image, and all biopsy-irrelevant operations are forbidden.

Biopsy Guideline

Press <F11 Biopsy> to enter Biopsy or tap [Biopsy] on the touch screen.

■ Select the biopsy bracket angle/guide line

If the needle-guided bracket supports more than one biopsy angle, select the angle/guideline by touching the [Bracket] on the touch screen (last two letters are angle or the guide line).

■ Select the guide line dot size

Tap [Dot Size] to select the dot size from Small, Medium and Large.

Tip:

- The guide line is a dotted line which consists of two kinds of dots. The distance between two dots is depth-dependent. Move the cursor over the big dot and a numeral, representing the biopsy depth, is displayed.
- The biopsy guidezone adjusts along with image adjustments, such as image inversion/rotations, zoom and depth changes.
- When the imaging depth and area are changed, the guide line is adjusted.

■ Exit

- Tap [Bracket] to be OFF or press <F11 Biopsy>.

Tips: in real-time status, press <F11 Biopsy> to exit biopsy status; in frozen status, press <F11 Biopsy> to hide/show the guide line if biopsy function is enabled.

Verification

Tap [Verify] to open the Biopsy Verify menu.

- Adjust the guide line position
Rotate the knob under [Position] on the touch screen to change the position of the guide line.
- Adjust the angle
Rotate the knob under [Angle] on the touch screen to change the guide line angle.
- Save the verified settings
After the position and angle of the guide line are adjusted, tap [Save] and the system saves the current guide line settings. If biopsy is entered again, the displayed Position and Angle are the verified value.
- Restore the factory default settings
Tap [Load Factory] and the position and angle of the guide line are restored to the factory default settings.
- Exit biopsy verify status
Tap [Exit] and the system exits the guide line verification status.

13.2.5 Removing the Needle-guided Bracket

- NGB-004
Hold the probe in the left hand, unscrew the locking nut with the right hand to open the retaining clamp, and then raise the needle-guided bracket to separate the locating bulge from the locating grooves.
- NGB-005
Hold the probe and the needle-guided bracket; open the grip knob of the needle-guided bracket.
- NGB-006
Metal needle-guided bracket:
 - (1) Screw out the nut on the guiding block to loose the guiding block and the needle-guided bracket.

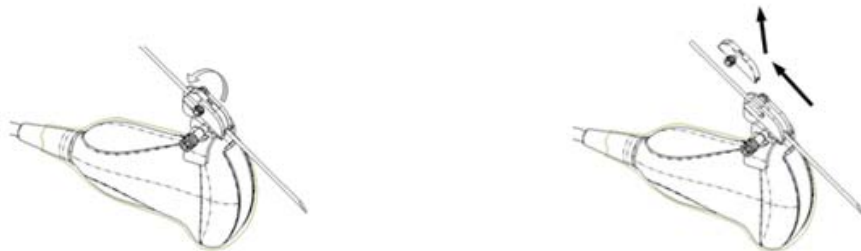

- (2) Take the guiding block away in the direction of the needle tail, and then separate the needle from the transducer and the residual parts of the needle-guided bracket.
- (3) Screw out the locking nut on the needle-guided bracket to loose the bracket with the transducer.



- (4) Hold the transducer with one hand, and then separate the needle-guided bracket from the transducer.

Plastic needle-guided bracket:

- (1) Remove the guiding block slightly along the direction of the needle's tail.
- (2) Separate the residual part of the needle-guide bracket and the probe from the needle.

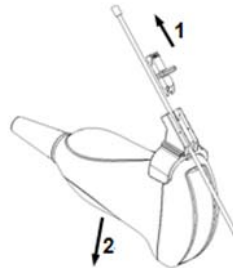

- (3) Remove the support of needle-guided bracket from the probe.

■ NGB-007

Metal needle-guided bracket:

- (1) Screw the nut of the guiding block and remove the guiding block slightly along the direction of the needle's tail.

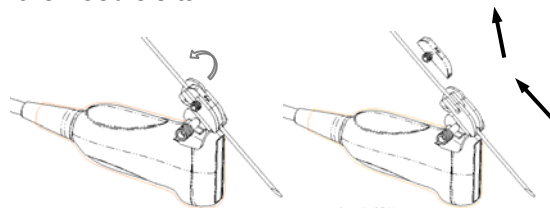

- (2) Separate the residual part of the needle-guided bracket and the probe from the needle.
- (3) Screw the pinch nut of the bracket, and remove the needle-guided bracket from the probe.

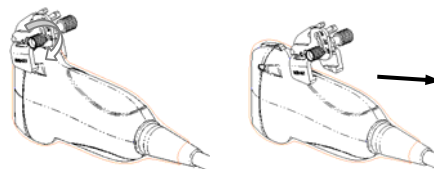

Plastic needle-guided bracket:

- (1) Remove the guiding block slightly along the direction of the needle's tail.
- (2) Separate the residual part of the needle-guide bracket and the probe from the needle.
- (3) Remove the support of needle-guided bracket from the probe.

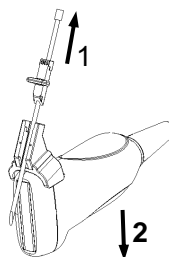

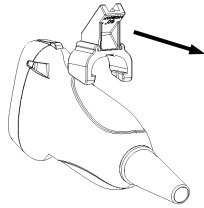

■ NGB-011

Hold the probe and the needle-guided bracket, and then open the grip knob of the needle-guided bracket.

■ NGB-016

(1) Screw out the nut on the guiding block to release the biopsy needle.

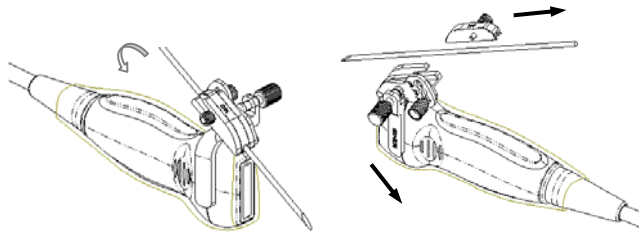

(2) Remove the guiding block in the direction of the needle tail, and then remove the needle.

(3) Screw the pinch nut of the bracket to release the needle-guided bracket.

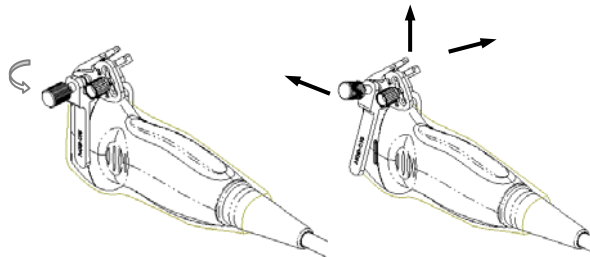

(4) Separate the probe and the needle-guided bracket.

13.2.6 Clean and Sterilize the Needle-guided Bracket

Cleaning

1. Wear sterile gloves to prevent infection.
2. Wash the needle-guided bracket with water or soap water to remove all the external matters. Or, clean the needle-guided bracket with urethane sponge.
3. Wipe off the water on the needle-guided bracket using sterile cloth or gauze after washing it.

Sterilization

1. Wear sterile gloves to prevent infection.
2. Clean the needle-guided bracket before sterilizing it. MINDRAY recommends the following solution or sterilizing system to sterilize the needle-guided bracket.
3. Follow local regulations when selecting and using the disinfectant.

■ Glutaraldehyde-based sterilant (only applicable for plastic needle-guided bracket):

Chemical name	Trade name	Procedures
Glutaraldehyde (2.2-2.7%)	Cidex Activated Glutaraldehyde Solution	Please refer to the instructions provided by the manufacturer of the solution for details. Soak the transducer into the activated solution for 10 hours (20-25°C).

- Refer to the instructions provided by the chemical manufacturer concerning concentration of the solution, and method of disinfections and dilution. Note that the glutaraldehyde disinfectant solution needs an activating solution.
- Rinse the needle-guided bracket thoroughly with sterile water to remove all chemical residues on it.
- Wipe off the water on the needle-guided bracket with sterile cloth or gauze after rinsing it.
- Before safety and performance is affected, plastic bracket NGB-007 can be sterilized by Cidex Activated Glutaraldehyde Solution for at least 233 times (10 hours for one time).

■ STERRAD 100S low-temperature hydrogen peroxide gas plasma sterilization system

Chemical name	Trade name	Procedures
Hydrogen peroxide gas plasma	Hydrogen peroxide vapor	Please refer to the instructions provided by the producer of the solution for details.

- Refer to the instruction of STERRAD 100S sterilizing system provided by the manufacturer for operation instructions and cautions.
- The sterilization system is available for metal needle-guided brackets.

■ Hydrogen Peroxide and Peroxyacetic Acid -based sterilant (only applicable for plastic needle-guided bracket):

Trade Name	Chemical Name	Procedures
Minnicare® Cold Sterilant	22% Hydrogen Peroxide 4.5% Peroxyacetic Acid	Dilute the sterilant with sterilized purified water (1:20). Immersed time: 11 hours. Temperature: 20°C-25°C. Please refer to the instructions provided by the manufacturer of the solution for details.

Before safety and performance is affected, plastic bracket NGB-007 can be sterilized by Minncare COLD STERILANT for at least 245 times (11 hours for one time).

■ High-pressure steam sterilization (only applicable for metal guided-bracket)

Autoclaving (moist heat) 121°C for 20 minutes.

The high-pressure steam/ immersion sterilization do not affect the bracket dual life, and the dual life is affected by the daily application of the bracket. Please check the appearance of the bracket before using.

NOTE: Repeated sterilization may degrade the safety and performance of the needle-guided bracket.

13.2.7 Storage and Transportation

- Don't use the carrying case for storing the needle-guided bracket. If the carrying case is used for storage, it may become a source of infection.
- Between examinations, keep the needle-guided bracket in a sterile environment.
- When the needle-guided bracket is sent to your MINDRAY representative for repair, be sure to disinfect or sterilize it and keep it in the carrying case to prevent infection.
- Sterilize the carrying case as necessary.
- Store or transport the needle-guided bracket under the following ambient conditions:
 - Ambient temperature: -20°C to 55°C
 - Relative humidity: 30% to 85% (no condensation)

13.2.8 Disposal

Be sure to dispose the needle-guided bracket only after sterilizing it.
Contact your MINDRAY representative when disposing of this device.

13.3 Middle Line

Middle Line helps to locate and observe the focus point of lithotripsy wave during lithotripsy treatment. By means of providing information for the lithotripsy machine as well as a tool for watching the procedure of lithotripsy in real-time, you can adjust the intension and frequency of the lithotripsy wave through lithotripsy machine.

NOTE: This function in the ultrasound system is for lesion (stone) location and observation only. For details, please refer to lithotripsy machine accompanying manuals.

- To enter the mode: press [Menu] or tap [Middle Line] in the biopsy tab to enter the middle line function.

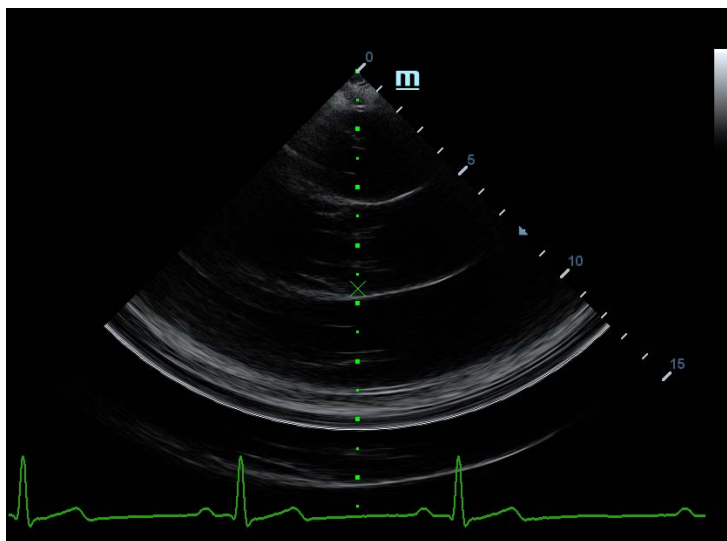

- The middle line is a vertical dotted line located in the middle of the screen, the position and direction of which cannot be changed.

- There is a mark icon of “x” located on the middle line which can be moved up and down along the line by rolling the track ball.
- To use the Middle Line function of the ultrasound system:
 - a) Use the trackball to change the mark position and by adjusting lithotripsy machine tools or patient posture to locate the stone center at the mark.
 - b) Read the depth of the mark by observing the depth caliper on the right of the image.
 - c) After the stone is located, refer to lithotripsy machine manuals to perform the lithotripsy.
- The depth of the mark is displayed in the image parameter area of the screen.

14 Acoustic Output

This section of the operator's manual applies to the overall system including the main unit, probes, accessories and peripherals. This section contains important safety information for operators of the device, pertaining to acoustic output and how to control patient exposure through use of the ALARA (as low as reasonably achievable) principle. Also this section contains information regarding the acoustic output testing and the real-time output display.

Read this information carefully before using the system.

14.1 Concerns with Bioeffects

Diagnostic ultrasound is recognized as being safe. In fact, there have been no reports of injuries to patients caused by diagnostic ultrasound.

It cannot be stated categorically that ultrasound is 100% safe. Studies have revealed that ultrasound with extremely high intensity is harmful to body tissues.

Diagnostic ultrasound technology has made a great leap forward during the last several years. This rapid advance has generated concerns about the potential risk of bioeffects when new applications or diagnostic technologies become available.

14.2 Prudent Use Statement

Although there are no confirmed biological effects on patients caused by exposures from present diagnostic ultrasound instruments, the possibility exists that such biological effects may be identified in the future. Thus ultrasound should be used in a prudent manner to provide medical benefit to the patient. High exposure levels and long exposure times should be avoided while acquiring necessary clinical information.

14.3 ALARA Principle (As Low As Reasonably Achievable)

It is required to practice ALARA when using ultrasound energy. Practicing ALARA ensures that the total energy level is controlled below a low enough level at which bioeffects are not generated while diagnostic information is being accumulated. The total energy is controlled by output intensity and total radiation time. The output intensity necessary for examinations differs depending on the patient and the clinical case.

Not all examinations can be performed with an extremely low level of acoustic energy. Controlling the acoustic level at an extremely low level leads to low-quality images or insufficient Doppler signals, adversely affecting the reliability of the diagnosis. However, increasing the acoustic power more than necessary does not always contribute to an increase in quality of information required for diagnosis, rather increasing the risk of generating bioeffects.

Users must take responsibility for the safety of patients and utilize ultrasound deliberately. Deliberate use of ultrasound means that output power of ultrasound must be selected based on ALARA.

Additional information regarding the concept of ALARA and the possible bioeffects of Ultrasound is available in a document from the AIUM (American Institute of Ultrasound Medicine) title “*Medical Ultrasound Safety*”.

14.4 MI/TI Explanation

14.4.1 Basic Knowledge of MI and TI

The relationship of various ultrasound output parameters (frequency, acoustic pressure and intensity, etc.) to bioeffects is not fully understood presently. It is recognized that two fundamental mechanisms may induce bioeffects. One is a thermal bioeffect with tissue absorption of ultrasound, and another one is a mechanical bioeffect based on cavitations. Thermal Index (TI) gives the relative index of temperature increase by thermal bioeffect, and Mechanical Index (MI) gives the relative index of mechanical bioeffect. TI and MI indices reflect instantaneous output conditions, so they DO NOT consider the cumulative effects of the total examination time. TI and MI models contain practical simplifications to complex bioeffects interaction. Then the operator should be aware that the actual worst case temperature rise may be up to several times higher than the displayed TI value.

■ MI (Mechanical Index):

The mechanical bioeffects are the result of compression and decompression of insonated tissues with the formation of micro bubbles that may be referred to as cavitations.

MI is an index that shows the possibility of the cavitations generation based on acoustic pressure, and the value in which the peak-rarefactional acoustic pressure is divided by the square root of the frequency. Therefore MI value becomes smaller when the frequency is higher or the peak-rarefactional acoustic pressure is lower, it becomes difficult to generate the cavitations.

$$MI = \frac{P_{r, \alpha}}{\sqrt{f_{\text{awf}}} \times C_{MI}}$$

$$C_{MI} = 1 \text{ (MPa} / \sqrt{\text{MHz}} \text{)}$$

For the frequency 1 MHz and the peak-rarefactional acoustic pressure 1 MPa, MI becomes 1. It is possible to think MI to be one threshold of the cavitations generation. Especially, it is important to keep MI value to be low when both gases and the soft tissues exist together, for such as lung exposure in cardiac scanning and bowel gas in abdominal scanning.

■ TI (Thermal Index):

TI is determined by the ratio of the total acoustic power to the acoustic power required to raise the tissue temperature by 1 degree C. In addition, because the temperature rises is greatly different according to tissue structures, TI is divided three kinds: TIS (Soft-tissue Thermal Index), TIB (Bone Thermal Index) and TIC (Cranial-bone Thermal Index).

- TIS: Thermal index related to soft tissues, such as abdominal and cardiac applications.

- TIB: Thermal index for applications, such as fetal (second and third trimester) or neonatal cephalic (through the fontanel), in which the ultrasound beam passes through soft tissue and a focal region is in the immediate vicinity of bone.
- TIC: Thermal index for applications, such as pediatric and adult cranial applications, in which the ultrasound beam passes through bone near the beam entrance into the body.

Although the output power is automatically controlled for the selected applications, high TI values should be kept to a minimum or avoided in obstetric applications. WFUMB (World Federation for Ultrasound in Medicine and Biology) guidelines: state that temperature increase of 4 degree C for 5 min or more should be considered as potentially hazardous to embryonic and fetal tissue.

The smaller the MI/TI values, the lower the bioeffects.

14.4.2 MI/TI Display

TI and MI values are displayed in the upper part of the screen in real-time. The operator should monitor these index values during examinations and ensure that exposure time and output values are maintained at the minimum amounts needed for effective diagnosis.

NOTE: If there is a value of MI or TI exceeds 1.0, you must be careful to practice the ALARA principle.

The display precision is 0.1.

Display accuracy of MI is $\pm 28.5\%$, and TI is $\pm 38.7\%$.

14.5 Acoustic Power Setting

■ Acoustic power adjustment

Click [A. power] in the soft menu or the menu to adjust the acoustic power percentage, and its value is displayed on the corresponding item as well as at the top of the screen. The greater the acoustic power percentage, the greater the current acoustic output.

When the image is frozen, the system stops transmitting acoustic power.

■ Default setting of acoustic power

Selection of diagnostic applications is the most important factor for controlling ultrasound output.

The permissible level of intensity of ultrasound differs depending on the region of interest. For fetal examinations, in particular, much care must be exercised.

In this system, imaging setups can be created using the ultrasound output set by you. At this time, the default function is disabled. It is the user's responsibility for any change to the default settings.

Default choices

Initial power	7% to 100%*
---------------	-------------

*Definition of 100%: The maximum acoustic power of a transducer determined by the increase in transducer surface temperature in the selected mode and the acoustic power restrictions specified by the FDA.

NOTE: This system automatically returns to the settings whenever changes are made to the values (when you turn on the power, switch between probes, press <End Exam>, or select Return in the Setup menu). In the factory default settings, the Acoustic Output is limited below 100%. Following the ALARA restriction, you are allowed to increase the acoustic power under FDA 510(k) Guidance-Track3 limits and to set it in the image preset screen.

The acoustic output of the system has been measured and calculated in accordance with IEC60601-2-37, FDA 510(K) GUIDANCE, Acoustic Output Measurement Standard for Diagnostic Ultrasound Equipment (NEMA UD-2 2004) and the "Standard for Real-Time Display of Thermal and Mechanical Acoustic Output Indices on Diagnostic Ultrasound Equipment (AIUM and NEMA UD-3 2004).

14.6 Acoustic Power Control

The qualified operator may use the system controls to limit the ultrasound output and to adjust the quality of the images. There are three categories of system controls relative to output. They are controls that have direct effect on the output, controls that indirectly control output and controls that are receiver controls.

■ Direct Controls

It is possible to control, if necessary, the acoustic output with the soft menu control on the control panel. In this case, the maximum value of the acoustic output never exceeds an MI of 1.9, TI of 6 and an $I_{SPTA,3}$ of 720 mW/cm² in any mode of operation.

■ Indirect Controls

The controls that indirectly affect output are many imaging parameters. These are operating modes, frequency, focal point positions, image depth and pulse repetition frequency (PRF).

The operating mode determines whether the ultrasound beam is scanning or non-scanning. Thermal bioeffect is closely connected to M mode, Doppler and Color mode.

Acoustic attenuation of tissue is directly related to transducer frequency.

The focal point is related to active aperture of transducer and beam width.

For the higher PRF (pulse repetition frequency), the more output pulses occur over a period of time.

■ Receiver Controls

The receiver controls (for example, gain, dynamic range, and image post-processing, etc.) do not affect output. These controls should be used, when possible, to improve the image quality before using controls that directly or indirectly affect output.

14.7 Acoustic Output

14.7.1 Derated Ultrasonic Output Parameters

In order to determine the relevant Ultrasonic Output Parameters, a method is used which allows for the comparison of ultrasound systems which operate at different frequencies and are focused at different depths. This approach, called "derating" or "attenuating", adjusts the acoustic output as measured in a water tank to account for the effect of ultrasound propagation through tissue. By convention, a specific average intensity attenuation value is used, which corresponds to a loss of 0.3 dB/cm/MHz. That is, the

intensity of ultrasound will be reduced by 0.3 dB/MHz for every centimeter of travel from the transducer. This can be expressed by the following equation:

$$I_{atten} = I_{water} \times 10^{(-0.3/10 \times f_c \times z)}$$

Where I_{atten} is the attenuated intensity, I_{water} is the intensity measured in a water tank (at distance z), f_c is the center frequency of the ultrasound wave (as measured in water), and z is the distance from the transducer. The equation for attenuating pressure values is similar except that the attenuation coefficient is 0.15 dB/cm/MHz, or one-half the intensity coefficient. The intensity coefficient is double the pressure coefficient because intensity is proportional to the square of pressure.

Although the attenuation coefficient chosen, 0.3 dB/cm/MHz, is significantly lower than any specific solid tissue in the body, this value was chosen to account for fetal examinations. In early trimester ultrasound fetal examinations, there may be a significant fluid path between the transducer and the fetus, and the attenuation of fluid is very small. Therefore the attenuation coefficient was lowered to account for this case.

14.7.2 Limits of Acoustic Output

In accordance with the FDA Track 3 requirements, the derating (or attenuated) approach was incorporated into the FDA Acoustic Output Limits, as listed below. The maximum acoustic output level from any transducer in any operating mode is expected to fall below these limits.

FDA Maximum Acoustic Output Limits for Track 3 (Attenuated Values)

Application	$I_{spta.3}$ (mW/cm ²)	$I_{sppta.3}$ (W/cm ²)	MI
Regions (except eyes)	720	≤ 190	or ≤ 1.9

14.7.3 Differences between Actual and Displayed MI and TI

In operation, the system will display to the operator the Acoustic Output Parameters Thermal Index, TI, or Mechanical Index, MI (or sometimes both parameters simultaneously). These parameters were developed as general indicators of risk from either thermal or mechanical action of the ultrasound wave. They serve to indicate to the operator whether a particular setting of the system increases or decreases the possibility of Thermal or Mechanical effect. More specifically, they were designed to assist in the implementation of the ALARA principle. As an operator changes a given system control, the potential effect of the change in output will be indicated. However, the Thermal Index is not the same as temperature rise in the body, for several reasons. First of all, in order to provide a single display index to you, a number of simplifying assumptions had to be made. The biggest assumption was the use of the attenuating formula described above, which is much lower than the actual value for most tissues within the body. Scanning through muscle or organ tissue, for example, will produce much higher attenuation than 0.3 dB/cm/MHz. There were also significant simplifications made for the thermal properties of tissue. Therefore, scanning through highly perfused tissue, such as the heart or vasculature, will produce significantly less thermal effect than that suggested by the Thermal Index.

Similarly, the Mechanical Index was derived to indicate the relative possibility of mechanical (cavitation) effects. The MI is based on the derated peak-rarefactional pressure and the center frequency of the ultrasound wave. The actual peak-rarefactional pressure is affected by the actual attenuation caused by tissue in the path between the transducer and the focal point. Again, all solid tissues within the body have higher attenuation than the proscribed 0.3 dB/cm/MHz value, and therefore, the actual peak-rarefactional pressure will be lower. Further, the actual peak-rarefactional pressure will change depending upon the region of the body being scanned.

For these reasons, the TI and MI displays should only be used to assist the operator in implementing ALARA at the time of the patient examination.

14.8 Measurement Uncertainty

I_{spta}	28.5%
I_{sppa}	28.5%
Center frequency (f_c)	2%
Total power (W)	28.5%
	(5.1% for Scan-mode and Combined-mode)
Peak-rarefactional pressure	14.7%

14.9 References for Acoustic Power and Safety

1. "Bioeffects and Safety of Diagnostic Ultrasound" issued by AIUM in 1993
2. "Medical Ultrasound Safety" issued by AIUM in 1994
3. "Acoustic Output Measurement Standard for Diagnostic Ultrasound Equipment, Revision 3" issued by AIUM/NEMA in 2004
4. "Standard for real-time display of thermal and mechanical acoustic output indices on diagnostic ultrasound equipment, Revision 2" issued by AIUM/NEMA in 2004
5. "Information for Manufacturers Seeking Marketing Clearance of Diagnostic Ultrasound Systems and Transducers" issued by FDA in 2008.
6. "Medical electrical equipment – Part 2-37: Particular requirements for the safety of ultrasonic medical diagnostic and monitoring equipment" issued by IEC in 2005.

15 EMC Guidance and Manufacturer's Declaration

The system complies with the EMC standard IEC 60601-1-2: 2007.

-  **WARNING:**
1. The use of unapproved accessories may diminish system performance.
 2. Use of components, accessories, probes, and cables other than those specified may result in increased emission or decreased immunity of system.
 3. The system or its components should not be used adjacent to or stacked with other equipment. If adjacent or stacked use is necessary, the system or its components should be observed to verify normal operation in the configuration in which it will be used.
 4. Operation of system, in the case that the patient physiological signal is lower than the minimum amplitude or value specified in the product specifications, results may be inaccurate (results can be obtained when the HR is in the range of 30-250 bmp or when the QRS wave amplitude is between 0.5-5 mV.)

- NOTE:**
1. The system needs special precautions regarding EMC and needs to be installed and put into service according to the EMC information provided below.
 2. Other devices may interfere with this system even though they meet the requirements of **CISPR** in the corresponding standards.
 3. Preventing conducted RF immunity. Due to technological limitations, the conducted RF immunity level are limited to 3 Vrms level, conducted RF interference above 3Vrms may cause wrong diagnosis and measurements. We suggest that you position system further from sources of conducted RF noise.
 4. Portable and mobile RF communications equipment can affects system. See tables 1, 2, 3, and 4 below.

If the system is operated within the electromagnetic environment listed in Table 2 and Table 3, the system will remain safe and will provide the following basic performances:

- Imaging;
- Doppler acoustic spectral displaying;
- Taking measurements;
- Patient information;
- Date/time information.

TABLE 1

GUIDANCE AND MINDRAY DECLARATION—ELECTROMAGNETIC EMISSIONS		
The system is intended for use in the electromagnetic environment specified below. The customer or the user of system should assure that it is used in such an environment.		
EMISSIONS TEST	COMPLIANCE	ELECTROMAGNETIC ENVIROMENT— GUIDANCE
RF emissions CISPR 11	Group 1	The system uses RF energy only for its internal function. Therefore, its RF emissions are very low and are not likely to cause any interference in nearby electronic equipment.
RF emissions CISPR 11	Class B	The system is suitable for use in all establishments including domestic establishments and those directly connected to the public low-voltage power supply network that supplies buildings used for domestic purposes
Harmonic Emissions IEC 61000-3-2	Class A	
Voltage Fluctuations/ Flicker Emissions IEC 61000-3-3	Compliance	

TABLE 2

GUIDANCE AND MINDRAY DECLARATION—ELECTROMAGNETIC IMMUNITY			
The system is intended for use in the electromagnetic environment specified below. The customer or the user of system should assure that it is used in such an environment.			
IMMUNITY TEST	IEC 60601 TEST LEVEL	COMPLIANCE LEVEL	ELECTROMAGNETIC ENVIRONMENT-GUIDANCE
Electrostatic Discharge(ESD) IEC 61000-4-2	±6 kV contact; ±8 kV air	±6 kV contact; ±8 kV air	Floors should be wood, concrete or ceramic tile. If floors are covered with synthetic material, the relative humidity should be at least 30%.
Electrical fast Transient / burst IEC 61000-4-4	±2 kV for power supply lines;	±2 kV for power supply lines;	Mains power quality should be that of a typical commercial or hospital environment.
Surge IEC 61000-4-5	±1 kV line(s) to line(s); ±2 kV line(s) to earth	±1 kV line(s) to line(s); ±2 kV line(s) to earth	Mains power quality should be that of a typical commercial or hospital environment.
Voltage dips, Short interruptions and voltage variation on power supply input voltage IEC 61000-4-11	<5% U_T (>95% dip in U_T) for 0.5 cycle 40% U_T (60% dip in U_T) for 5 cycle 70% U_T (30% dip in U_T) for 25 cycle <5% U_T (>95% dip in U_T) for 5 sec	<5% U_T (>95% dip in U_T) for 0.5 cycle 40% U_T (60% dip in U_T) for 5 cycle 70% U_T (30% dip in U_T) for 25 cycle <5% U_T (>95% dip in U_T) for 5 sec	Mains power quality should be that of a typical commercial or hospital environment. If you require continued operation during power mains interruptions, it is recommended that our product be powered from an uninterruptible power supply or a battery.
Power frequency (50/60 HZ) magnetic field IEC 61000-4-8	3 A/m	3 A/m	Power frequency magnetic fields should be at levels characteristic of a typical location in a typical commercial or hospital environment.
NOTE: U_T is the A.C. mains voltage prior to application of the test level.			

TABLE 3

GUIDANCE AND MINDRAY DECLARATION—ELECTROMAGNETIC IMMUNITY			
The system is intended for use in the electromagnetic environment specified below. The customer or the user of system should assure that it is used in such an environment.			
IMMUNITY TEST	IEC 60601 TEST LEVEL	COMPLIANCE LEVEL	ELECTROMAGNETIC ENVIRONMENT-GUIDANCE
Conducted RF IEC 61000-4-6	3 Vrms 150 kHz - 80 MHz	3 Vrms	Portable and mobile RF communications equipment should be used no closer to any part of system, including cables, than the recommended separation distance calculated from the equation applicable to the frequency of the transmitter. Recommended separation distance $d = 1.2 \times \sqrt{P}$
Radiated RF IEC 61000-4-3	3 V/m 80MHz - 2.5GHz	3 V/m	$d = 1.2 \times \sqrt{P}$ 80 MHz to 800 MHz $d = 2.3 \times \sqrt{P}$ 800 MHz to 2.5GHz Where, P is the maximum output power rating of the transmitter in watts (W) according to the transmitter manufacturer and d is the recommended separation distance in meters (m). Field strengths from fixed RF transmitters, as determined by an electromagnetic site survey, should be less than the compliance level in each frequency range. Interference may occur in the vicinity of equipment marked with the following symbol: 
<p>Note 1 At 80 MHz and 800 MHz, the higher frequency range applies.</p> <p>Note 2 These guidelines may not apply in all situations. Electromagnetic propagation is affected by absorption and reflection from structures, objects and human body.</p>			

- Field strengths from fixed transmitters, such as base stations for radio (cellular /cordless) telephones and land mobile radios, amateur radio, AM and FM radio broadcast and TV broadcast cannot be predicted theoretically with accuracy.

To assess the electromagnetic environment due to fixed RF transmitters, an electromagnetic site survey should be considered. If the measured field strength in the location in which system is used exceeds the applicable RF compliance level above, system should be observed to verify normal operation. If abnormal performance is observed, additional measures may be necessary, such as reorienting or relocating system.

- Over the frequency ranges 150kHz to 80MHz, field strengths should be less than 3V/m.

TABLE 4

RECOMMENDED SEPARATION DISTANCES BETWEEN PORTABLE AND MOBILE RF COMMUNICATION DEVICE AND SYSTEM			
The system is intended for use in an electromagnetic environment in which radiated RF disturbance are controlled. The customer or the user of system can help prevent electromagnetic interference by maintaining a minimum distance between portable and mobile RF communication equipment (transmitters) and system as recommended below, according to the maximum output power of the communication equipment.			
Rated Maximum Output power of Transmitter (W)	Separation Distance According to Frequency of Transmitter (m)		
	150kHz -80MHz $d=1.2\sqrt{P}$	80MHz-800MHz $d=1.2\sqrt{P}$	800MHz-2.5GHz $d=2.3\sqrt{P}$
0.01	0.12	0.12	0.23
0.1	0.38	0.38	0.73
1	1.2	1.2	2.3
10	3.8	3.8	7.3
100	12	12	23
For transmitters at a maximum output power not listed above, the recommended separation distanced in meters (m) can be determined using the formula applicable to the frequency of the transmitter, where P is the maximum output power rating of the transmitter in watts (W) according to the transmitter manufacturer. If system image distortion occurs, it may be necessary to position system further from sources of conducted RF noise or to install external power source filter to minimize RF noise to an acceptable level.			
Note 1 At 80 MHz and 800 MHz, the separation distance for the higher frequency range applies.			
Note 2 These guidelines may not apply in all situations. Electromagnetic propagation is affected by absorption and reflection from structures, objects and human body.			

Cable sample

No.	Name	Cable length (m)	Shielding or not	Remark
1	Power Cord	2.3	No	/
2	ECG cable	4.0	Yes	/
3	Foot-switch control cable	2.9	Yes	/
4	Probe cable	2.4	Yes	Longest cable

■ Federal Communications Commission (FCC) Statement

The wireless module has been tested and found to comply with the limits for a class B digital device, pursuant to Part 15 of the FCC rules. These limits are designed to provide reasonable protection against harmful interference in a residential installation. This equipment generates, uses

and can radiate radio frequency energy and, if not installed and used in accordance with the instructions, may cause harmful interference to radio communications. However, there is no guarantee that interference will not occur in a particular installation. If this equipment does cause harmful interference to radio or television reception, which can be determined by turning the equipment off and on, the user is encouraged to try to correct the interference by one or more of the following measures:

- Reorient or relocate the receiving antenna.
- Increase the separation between the equipment and receiver.
- Connect the equipment into an outlet on a circuit different from that to which the receiver is connected.
- Consult the dealer or an experienced radio/TV technician for help.

16 System Maintenance

Routine system maintenance shall be carried out by the user. System maintenance after the warranty has expired is the full responsibility of the owner/operator.

The responsibility for maintenance and management of the product after delivery resides with the customer who has purchased the product.

If you have any questions, please contact Mindray Customer Service Department or sales representative.

-  **WARNING:**
1. Only an authorized Mindray service engineer can perform maintenance not specified in this operator's manual.
 2. For the sake of the system performance and safety, you should perform periodical checks for the system.

16.1 Daily Maintenance

You are responsible for daily maintenance.

16.1.1 Cleaning the System

-  **WARNING:**
1. Before cleaning the system, be sure to turn off the power and disconnect the power cord from the outlet. If you clean the system while the power is "On", it may result in electric shock.
 2. DO NOT directly spray solution onto the monitor, system control panel or hard surfaces that is under pressure or pumped. Ingress fluid leakage into the monitor or system can damage the monitor or system, causing possible electric shock or system failure.

 **CAUTION:** Do not spill water or other liquid into the system while you perform the cleaning. Otherwise it may result in malfunction or electric shock.

- NOTE:**
1. DO NOT use hydrocarbon glass cleaner or cleaner for OA (Office Automation) equipment to clean the monitor. These substances may cause deterioration of the monitor.
 2. Please clean the control panel periodically, otherwise the button may be blocked by dirt and the system will be buzzing while the button makes no response.

■ Cleaning the probe

- Tools: mild soapy water , dry soft cloth, soft brush
- Method:
 - a) Wipe out the dust attached to surface of probe head, connector and cable with dry soft cloth.
 - b) Use soft brush to brush the dust inside probe connector gently.
 - c) Remained stain or dust attached to surface of cable or surface of connector should be washed out by cloth with a little soapy water, and then air-dry.

NOTE: Don't use cloth with water to clean the probe connector.

Please refer to "13.1.5 Probes Cleaning and Disinfection" to perform cleaning and disinfection.

■ Cleaning the probe cable

Use soft dry cloth to wipe off stains from the probe cable.

If it is difficult to clean the stains thoroughly, use soft cloth dipped with mild detergent, and then let the cable air dry.

■ Cleaning the monitor and the touch screen

- Tool: soft dry cloth, clean or soapy water
- Method:

The surfaces of the monitor and touch screen should be cleaned with a soft dry cloth. Remaining stains should be wiped away using a cloth with a little clean or soapy water and then air dried.

■ Clean the Control Panel

- Tools: dry soft cloth, soapy water
- Method:

Use dry soft cloth to clean the surface of control panel (including keystrokes, encoders and sliders). If the control panel is dirty, moisten the soft cloth with a little mild soapy water and wipe off any stains. Use another dry soft cloth to remove any moisture and allow all hard surfaces to completely air-dry. If it is difficult to clean the control panel, disassemble the encoder caps first and then use mild soapy water to clean it.

NOTE: The control panel should be cleaned periodically; otherwise, keys maybe blocked by dirt and buzzer dings, keys don't work.

■ Clean Holders

- Tool: dry soft cloth , soapy water, soft brush
- Method:
 - a) Use dry soft cloth to wipe off the dust attached to inside, outside or gap of probe holder or gel holder. As to small intra-cavity probe holder or its gap, use the soft brush to brush the dust or stain.
 - b) Remained stain attached to inside, outside of holder should be washed out by cloth with a little soapy water after it was taken out, and then install the holder after air-dry.

■ Clean Cover

- Tools: dry soft cloth, soapy water
- Method:

Use dry soft cloth to clean the cover of the system. If the system is dirty, moisten the soft cloth with mild soapy water and wipe off any stains, then air-dry.

NOTE: Be sure to use soft brush to brush the dust attached to all the sockets or interfaces which can be seen (such as probe sockets, sockets or interfaces in IO panel and power supply panel), not the cloth with water.

■ Cleaning the trackball

- Tools: paper, dry cloth, mild soapy water
- Method:

1. Disassembling the trackball:

Press the bulges on the clamping ring using both hands and turn the ring about 35° clockwise until it lifts. Take out the ring and the rotary ball. Be careful not to drop the ball. See the figure below.

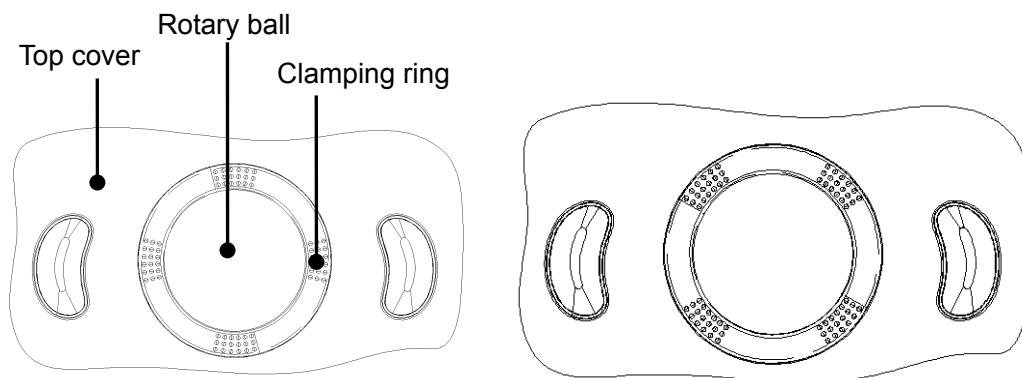

2. Cleaning

Clean the two long shafts, the bearing and the rotary ball with a clean soft dry cloth or paper.

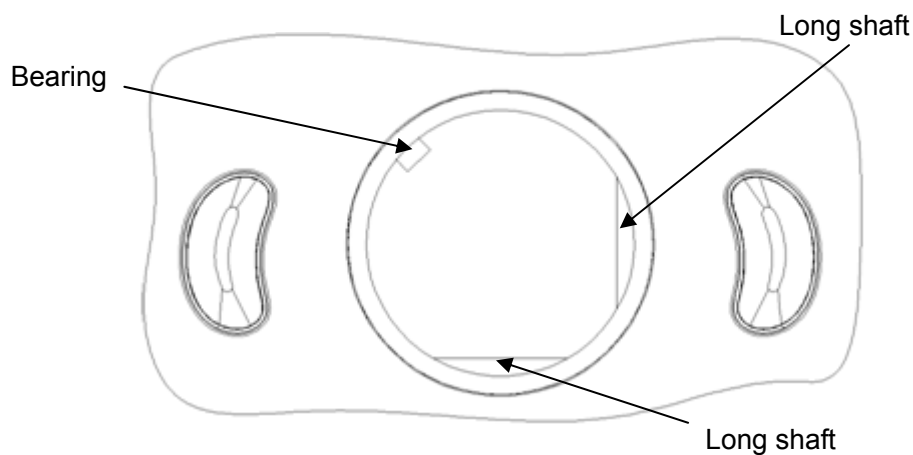

3. Installing the trackball

Put the rotary ball back in the trackball mechanism and put the clamping ring back in. Turn the ring counterclockwise until the bulges are flush with the top cover and the ring clicks and locks, meaning the ring is secured. See the figure below.

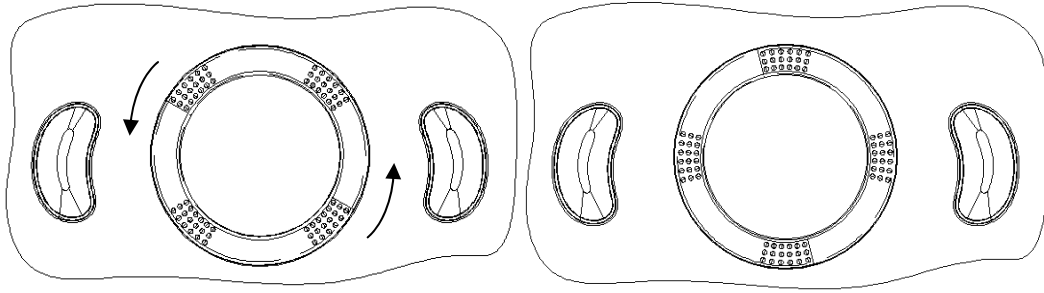

■ Cleaning the main panel

- Tools: soft dry cloth, soapy water
- Method:

Use a soft dry cloth to clean the surface of the control panel (including the keystrokes, encoders and sliders). If the control panel is dirty, moisten the soft cloth with a little mild soapy water and wipe away any stains. Use another soft dry cloth to remove any moisture and allow all hard surfaces to completely air dry. If the control panel is difficult to clean, disassemble the encoder caps first and then clean it with mild soapy water.

NOTE: The keyboard on the control panel should be cleaned periodically, otherwise the keys may become blocked with dirt and when the buzzer rings the keys will not work.

■ Cleaning the cover

- Tools: soft dry cloth, soapy water
- Method:

Use a soft dry cloth to clean the system's cover. If the system is dirty, moisten the soft cloth with mild soapy water, wipe away any stains, then air dry.

■ Clean dust-proof covers

- Tool: Soft brush
- Method:

1) Disassemble dust-proof cover before cleaning.

System dust-proof cover: Grab the lower side of the dust net frame, and then pull out the net.

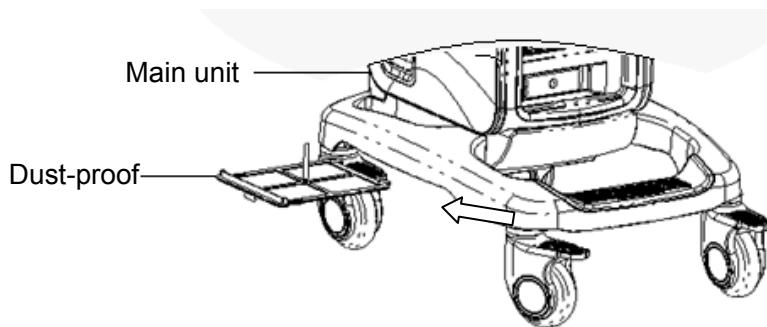

Probe port dust-proof cover: there is a probe port dust-proof cover at the front of the system, Pull it out.

- 2) Cleaning: with soft brush and then wipe off the dust.
- 3) Assemble dust-proof covers.

Input the dust-proof clasp into the slot of the main unit, push the dust-proof inward until the dust-proof clasp is blocked in the slot.

**CAUTION:**

Please clean all dust-proof covers of the system periodically (1 time per month); otherwise, system damage may result. Cleaning times can be increased when the system is used in the open air or somewhere dust is more.

16.1.2 Clean the Peripherals

Do the cleaning maintenance according to your actual peripheral configuration; items which are not configured can be skipped.

Content	Description
Color and B/W video printer	First wipe off dust or stain attached to the cover of printer with soft dry cloth, then clean the inside of printer. Be sure to do the cleaning maintenance according to the operation manual if is necessary.
Graph / text printer	First wipe off dust or stain attached to the cover of printer with soft dry cloth, then clean the inside of printer. Be sure to do the cleaning maintenance according to the operation manual if is necessary.
Footswitch	Use soft dry cloth with a little mild soap water to wipe off the dust or stain attached to the pedals or cable of foot switch.
Bar code scanner	First use soft dry cloth to wipe off dust attached to glass panel of scanner, then the dust or strain attached to cable and bracket. Be sure to do the especial cleaning maintenance according to the operation manual if is necessary.

16.1.3 Checking the Probe

- Visually check to confirm that there is no crack and expansion to probe head.
- Visually check to confirm that there is no deterioration or desquamation to probe cable.
- Visually check to confirm that there is no bend, destroyed or falling off pins to the connector.

16.1.4 Checking the Power Cable and Plug

- Visually check to confirm that there is no wrinkles, crack or deterioration; No crack and expansion to the surface of adapter.
- Manually check to confirm that there is no looseness or rupture. The connection of plug is reliable.

16.1.5 Checking Appearance

Check if there is any crack in the covers:

- Ultrasound system covers
- Probe appearance

16.1.6 Backup of the System Hard Drive

To prevent deterioration or loss of data stored in the system hard drive, create a backup copy of the hard drive at regular intervals.

16.2 Troubleshooting

If any persistent system malfunction is experienced, e.g. an onscreen error message, blank imaging screen, absent menus, please refer to the table below. If the failure can't be eliminated, please contact Mindray Customer Service Department or sales representative.

No.	Failure	Cause	Measure
1	After the power supply is turned on, the power indicator does not light on.	<ul style="list-style-type: none"> Abnormal power system or incorrect connection of the power cord. 	<ul style="list-style-type: none"> Check if the system is plugged in. Check if the system circuit breaker is in the Up position. Check if the plug has not become loosened or dislodged from the back of the system.
2	The power indicator of the monitor is light on, but image is blank.	<ul style="list-style-type: none"> The interval between turning off and restarting the system is too short – wait a minimum time of 20 seconds. The monitor brightness or contrast may be improperly set. 	<ul style="list-style-type: none"> Turn off the system and wait a minimum time of 1 minute, then restart the system. Adjust the monitor brightness and contrast back to factory defaults.
3	The monitor displays the characters and menus but no images.	<ul style="list-style-type: none"> The transmission power, overall gain or TGC controls are improperly set. Check if a probe is connected and/or fully connected. The system is in the frozen status. 	<ul style="list-style-type: none"> Adjust the transmission power, gain or TGC control. Ensure proper probe connection. Unfreeze the image.
4	The image quality is degraded	<ul style="list-style-type: none"> The exam mode is not correct. The settings of the image post processing are not correct. The image presets are inappropriate. 	<ul style="list-style-type: none"> Select an appropriate exam mode. Adjust the settings of the image via post processing or reset the post processing to the default values. Reset the factory default presets.
5	The button is responseless with the system buzzing	<ul style="list-style-type: none"> There is too much dirt blocking the button 	<ul style="list-style-type: none"> Check the control panel for the button being blocked and press it several times to release it. Clean the button.

Appendix A Barcode Reader

The product supports readers for logging data as patient ID: 1-D barcode reader (SYMBOL LS2208) . The laser transmitted by the reader is Class 2 laser.

WARNING: Class 2 laser adopts low power, visible LED. DO NOT stare into beam because of unknown hazards of transient radiation provided by class 2 laser.

CAUTION: Ensure the information acquired by barcode reader is consistent with the actual information.

There are 2 operation modes:

Hand-held mode: press the trigger to decode.

Hands-free mode: seat the reader in the stand to enter the mode, the reader decodes automatically.

Note: the reader does not support decoding of Multilanguage.

A.1 1-D Barcode Reader

A.1.1 Overview



1.	LED	Green: A barcode was successfully decoded. Red: A data transmission error or reader malfunction occurred.
2.	Scan window	Scan the barcode.
3.	Trigger	Press to decode

A.1.2 Setting Up the Reader (Take LS2208 as an example)

1. Plug the interface cable modular connector into the cable interface port on the bottom of the reader handle, and ensure the connector is properly secured.
2. Connect the other end of the interface cable to the host.

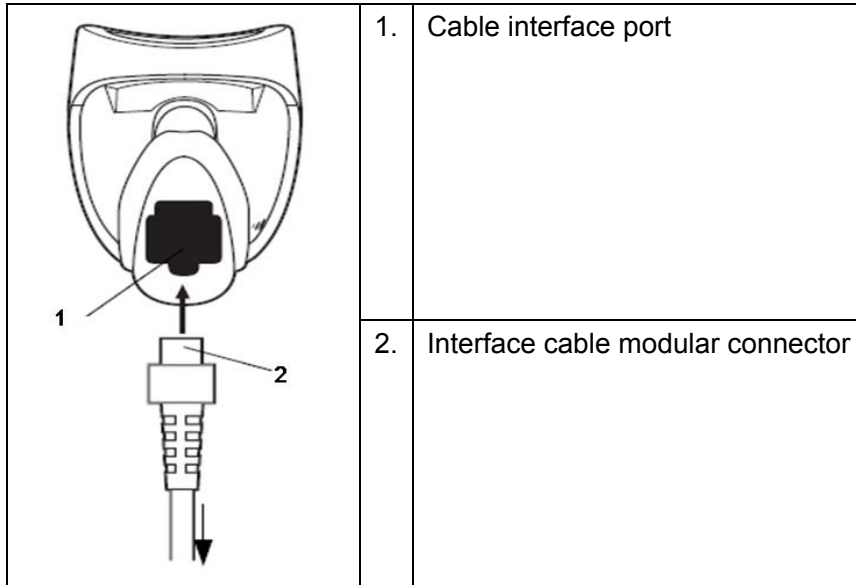

A.1.3 Setting

The reader has factory settings; please refer to A.4 for details.

The reader supports some user-defined functions as introduced below.

For more details, please contact the SYMBOL reader agents or Mindray Customer Service Department.

■ Volume setting:

Scan the following barcode to set the volume parameter.



Low Volume



Medium Volume



High Volume

■ Code 93 and codebar scanning:

To enable or disable Code 93, scan the appropriate barcode below.



Enable Code 93

To enable Codebar, scan the appropriate barcode below.



Enable Codabar

■ Code 39 full ASCII scanning:

Code 39 Full ASCII is a variant of Code 39 which pairs characters to encode the full ASCII character set. To enable or disable Code 39 Full ASCII, scan the appropriate barcode below.



Enable Code 39 Full ASCII

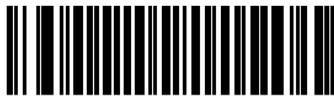

Disable Code 39 Full ASCII

■ I 2 of 5 symbols setting:

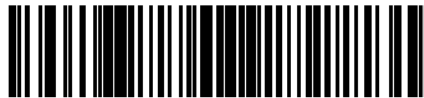

I 2 of 5 - One Discrete Length

Select this option to decode only I 2 of 5 symbols containing a selected length. Select the length using the numeric barcodes below. For example, to decode only I 2 of 5 symbols with 8 characters, scan **I 2 of 5 - One Discrete Length**, then scan **0** followed by **8**.



0



1



2



3



4



5



6



7



8



9

A.1.4 Scanning in Hand-Held Mode

1. Ensure all connections are secure.
2. Aim the reader at the barcode. Press the trigger.

Tips: Ensure the scan line crosses every bar and space of the symbol, see the figure below.

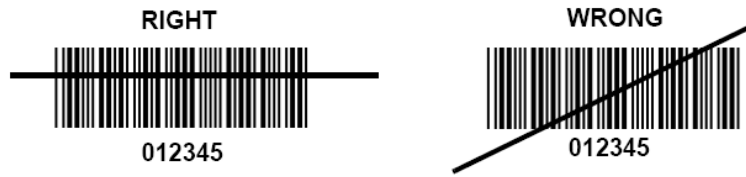

3. Upon successful decode, the reader beeps and the LED turns green.

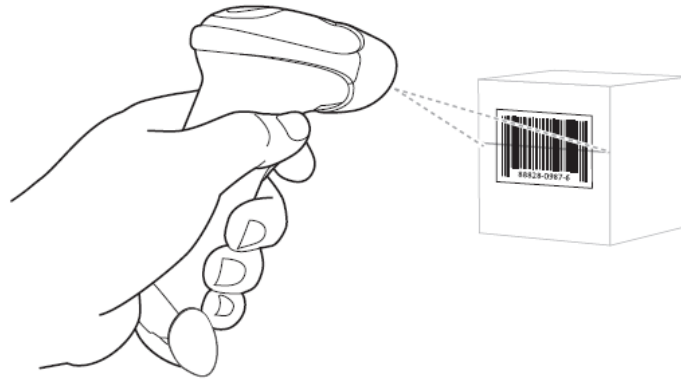

Tips: Do not hold the reader directly over the barcode. Laser light reflecting *directly* back into the reader from the barcode is known as specular reflection. This specular reflection can make decoding difficult. You can tilt the reader up to 55° forward or back and achieve a successful decode

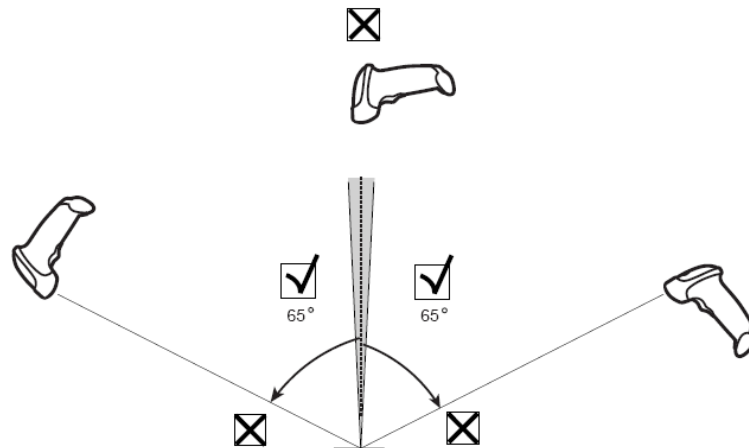

A.1.5 Scanning in Hands-Free Mode

Assembling the Intellistand

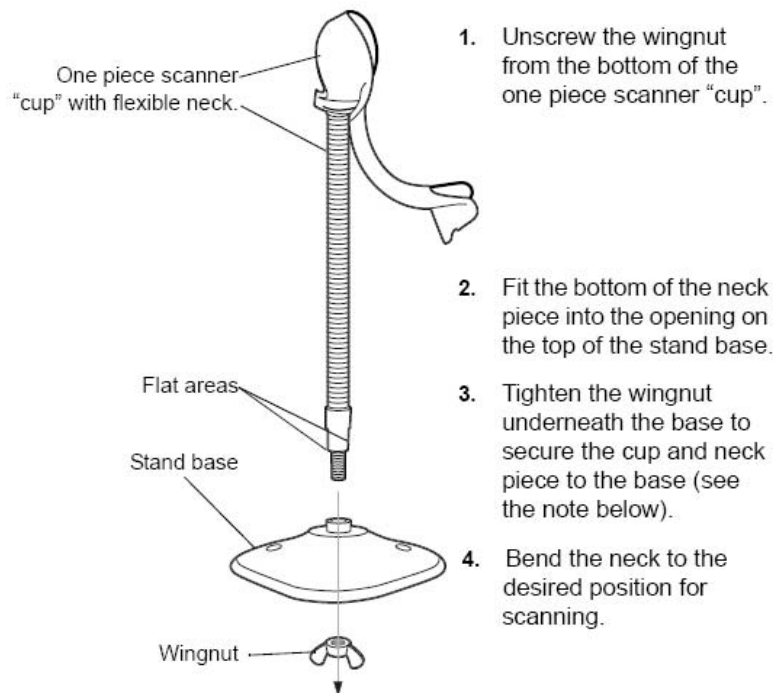

NOTE Before tightening the wingnut under the base, ensure that the flat areas on the flexible neck fit securely in the grooves in the base.

Mounting the Stand (optional)

You can attach the base of the reader's stand to a flat surface using two screws or double-sided tape (not provided).

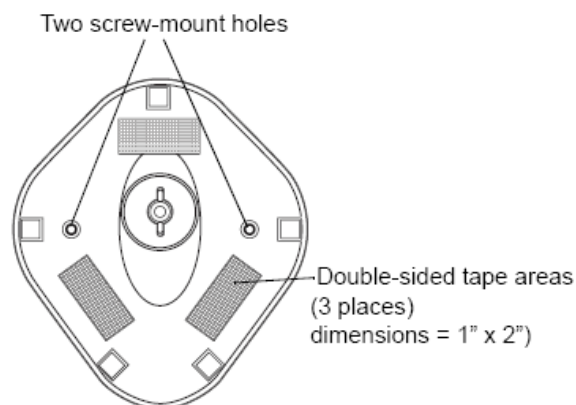

■ Screw Mount

- (1) Position the assembled base on a flat surface.
- (2) Screw one #10 wood screw into each screw-mount hole until the base of the stand is secure.

■ Tape Mount

- (1) Peel the paper liner off one side of each piece of tape and place the sticky surface over each of the three rectangular tape holders.
- (2) Peel the paper liner off the exposed sides of each piece of tape and press the stand on a flat surface until it is secure.

Scanning in Hands-Free Mode

When the reader is seated in the stand's "cup", the reader's built-in sensor places the reader in hands-free mode. When you remove the reader from the stand it operates in its normal hand-held mode.

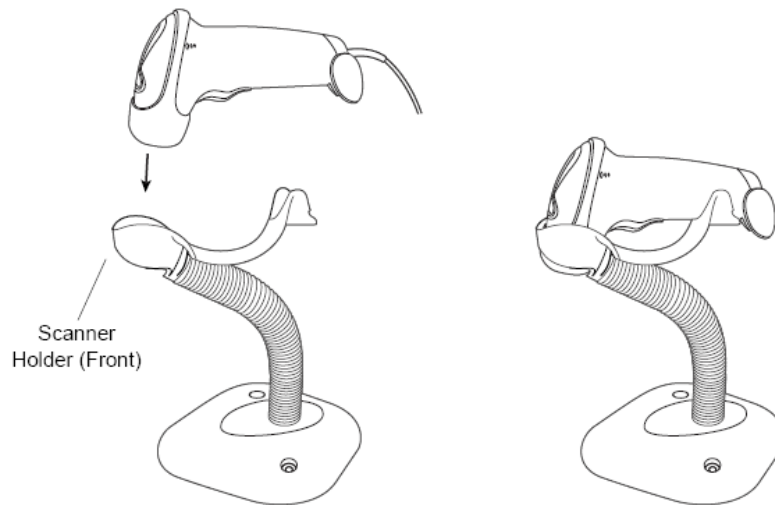

A.2 Parameter Defaults

Refer to the following table for parameter defaults of LS2208.

Parameter	Defaults
1-D Symbolologies	
UPC/EAN	
UPC-A	Enable
UPC-E	Enable
UPC-E1	Disable
EAN-8/JAN 8	Enable
EAN-13/JAN 13	Enable
Bookland EAN	Disable
Decode UPC/EAN/JAN Supplementals (2and 5 digits)	Ignore
UPC/EAN/JAN Supplemental Redundancy	10
Transmit UPC-A Check Digit	Enable
Transmit UPC-E Check Digit	Enable
Transmit UPC-E1 Check Digit	Enable
UPC-A Preamble	System Character
UPC-E Preamble	System Character
UPC-E1 Preamble	System Character
Convert UPC-E to A	Disable
Convert UPC-E1 to A	Disable
EAN-8/JAN-8 Extend	Disable
UCC Coupon Extended Code	Disable
Code 128	
Code 128	Enable
UCC/EAN-128	Enable
ISBT 128	Enable
Code 39	
Code 39	Enable
Trioptic Code 39	Disable
Convert Code 39 to Code 32 (Italian Pharmacy Code)	Disable
Code 32 Prefix	Disable
Set Length(s) for Code 39	2 to 55
Code 39 Check Digit Verification	Disable
Transmit Code 39 Check Digit	Disable

Parameter	Defaults
Code 39 Full ASCII Conversion	Disable
Buffer Code 39	Disable
Code 93	
Code 93	Enable
Set Length(s) for Code 93	4 to 55
Interleaved 2 of 5 (ITF)	
Interleaved 2 of 5 (ITF) Enable	Enable
Set Lengths for I 2 of 5	14
I 2 of 5 Check Digit Verification	Disable
Codabar (NW - 7)	
Codabar	Enable
Set Lengths for Codabar	5 to 55
CLSI Editing	Disable
NOTIS Editing	Disable

A.3 Maintenance

Cleaning the exit window is the only maintenance required. A dirty window can affect scanning accuracy.

- Do not allow any abrasive material to touch the window
- Remove any dirt particles with a damp cloth
- Wipe the window using a tissue moistened with ammonia/water
- Do not spray water or other cleaning liquids directly into the window.

Appendix B Electrical Safety Inspection

The following electrical safety tests are recommended as part of a comprehensive preventive maintenance program. They are a proven means of detecting abnormalities that, if undetected, could prove dangerous to either the patient or the operator. Additional tests may be required according to local regulations.

All tests can be performed using commercially available safety analyzer test equipment. These procedures assume the use of a 601PROXL International Safety Analyzer or equivalent safety analyzer. Other popular testers complying with IEC 60601-1 used in Europe such as Fluke, Metron, or Gerb may require modifications to the procedure. Follow the instructions of the analyzer manufacturer.

The electrical safety inspection should be periodically performed every two years. The safety analyzer also proves to be an excellent troubleshooting tool to detect abnormalities of line voltage and grounding, as well as total current loads.

B.1 Power Cord Plug

B.1.1 The Power Plug

Test Item		Acceptance Criteria
The power plug	The power plug pins	No broken or bent pin. No discoloured pins.
	The plug body	No physical damage to the plug body.
	The strain relief	No physical damage to the strain relief. No plug warmth for device in use.
	The power plug	No loose connections.
The power cord		No physical damage to the cord. No deterioration to the cord.
		For devices with detachable power cords, inspect the connection at the device.
		For devices with non-detachable power cords, inspect the strain relief at the device.

B.2 Device Enclosure and Accessories

B.2.1 Visual Inspection

Test Item	Acceptance Criteria
The enclosure and accessories	No physical damage to the enclosure and accessories.
	No physical damage to meters, switches, connectors, etc.
	No residue of fluid spillage (e.g., water, coffee, chemicals, etc.).
	No loose or missing parts (e.g., knobs, dials, terminals, etc.).

B.2.2 Contextual Inspection

Test Item	Acceptance Criteria
The enclosure and accessories	No unusual noises (e.g., a rattle inside the case).
	No unusual smells (e.g., burning or smoky smells, particularly from ventilation holes).
	No taped notes that may suggest device deficiencies or operator concerns.

B.3 Device Labeling

Check the labels provided by the manufacturer or the healthcare facility are present and legible.

- Main unit label
- Integrated warning labels

B.4 Protective Earth Resistance

- Plug the probes of the analyzer into the device's protective earth terminal and protective earth terminal of the AC power cord.
- Test the earth resistance with a current of 25 A.
- Verify the resistance is less than limits.

LIMITS

ALL COUNTRIES R = 0.2 Ω Maximum

B.5 Earth Leakage Test

Run an Earth Leakage test on the device being tested before performing any other leakage tests.

The following outlet conditions apply when performing the Earth Leakage test:

- normal polarity(Normal Condition),
- reverse polarity(Normal Condition),
- normal polarity with open neutral(Single Fault Condition),
- reverse polarity with open neutral(Single Fault Condition)

LIMITS

For UL60601-1,

- 300 μ A in Normal Condition
- 1000 μ A in Single Fault Condition

For IEC60601-1,

- 500 μ A in Normal Condition
- 1000 μ A in Single Fault Condition

B.6 Enclosure Leakage Test

The following outlet conditions apply when performing the Enclosure Leakage test.

- normal polarity(Normal Condition);
- reverse polarity(Normal Condition),
- normal polarity with open neutral(Single Fault Condition);
- reverse polarity with open neutral(Single Fault Condition).
- normal polarity with open earth(Single Fault Condition);
- reverse polarity with open earth(Single Fault Condition).

LIMITS

For UL60601-1,

- 100 μ A in Normal Condition
- 300 μ A in Single Fault Condition

For IEC60601-1:

- 100 μ A in Normal Condition
- 500 μ A in Single Fault Condition

B.7 Patient Leakage Current

Patient leakage currents are measured between a selected applied part and mains earth. All measurements have a true RMS only

The following outlet conditions apply when performing the Patient Leakage Current test.

- normal polarity(Normal Condition);
- reverse polarity(Normal Condition),
- normal polarity with open neutral(Single Fault Condition);
- reverse polarity with open neutral(Single Fault Condition).
- normal polarity with open earth(Single Fault Condition);
- reverse polarity with open earth(Single Fault Condition).

LIMITS

For CF  applied parts

- 10 μ A in Normal Condition
- 50 μ A in Single Fault Condition

For BF  applied parts

- 100 μ A in Normal Condition
- 500 μ A in Single Fault Condition

B.8 Mains on Applied Part Leakage

The Mains on Applied Part test applies a test voltage, which is 110% of the mains voltage, through a limiting resistance, to selected applied part terminals. Current measurements are then taken between the selected applied part and earth. Measurements are taken with the test voltage (110% of mains) to applied parts in the normal and reverse polarity conditions

The following outlet conditions apply when performing the Mains on Applied Part test.

- Normal Polarity;
- Reversed Polarity

LIMITS

■ For CF  applied parts: 50 μ A

■ For BF  applied parts: 5000 μ A

B.9 Patient Auxiliary Current

Patient Auxiliary currents are measured between any selected Applied Part connector and the remaining Applied Part connector. All measurements may have a true RMS only response.

The following outlet conditions apply when performing the Patient Auxiliary Current test.

- normal polarity(Normal Condition);
- reverse polarity(Normal Condition),
- normal polarity with open neutral(Single Fault Condition);
- reverse polarity with open neutral(Single Fault Condition).
- normal polarity with open earth(Single Fault Condition);
- reverse polarity with open earth(Single Fault Condition).

LIMITS

For CF  applied parts,

- 10 μ A in Normal Condition
- 50 μ A in Single Fault Condition

For BF  applied parts,

- 100 μ A in Normal Condition
- 500 μ A in Single Fault Condition

NOTE: Make sure the safety analyzer is authorized comply with requirement of IEC60601-1.
Follow the instructions of the analyzer manufacturer.

Appendix C iScanHelper

By providing the referential information, such as, the ultrasonic image, the anatomic graphic, scanning pictures/other scanning tips or diagnosis comments, the system helps the doctors to operate the scanning by iScanHelper. Furthermore, it is a good platform for the self-learning and training of ultrasound scanning technique for doctors. The system also plays a role in the assistant software system in fulfilling training and education.

Tips: iScanHelper feature is available under abdominal, urological and small parts, fetal cardiac exam modes.

NOTE: THIS “iScanHelper” IS FOR REFERENCE OR TUTORIAL PURPOSES ONLY, AND THE MANUFACTURER WILL NOT BE LIABLE FOR DAMAGES AND/OR OTHER UNDESIRABLE CONSEQUENCE IN ANY KIND THAT MAY OCCUR TO THE PATIENT OR THE USERS BY USING THE SOFTWARE.

C.1 Enter/ Exit

- Enter
Press the user-defined key for entering iScanHelper (setting path: [Setup] (F10) → [System] → [Key Config.]).
- Exit
Press the user-defined key again to exit iScanHelper.

C.2 Use iScanHelper for Reference

1. Perform ordinary scanning procedure.
2. Press the user-defined key for entering iScanHelper to enter iScanHelper status.
3. Rotate the trackball to move the cursor onto the target view name in the view selecting box and then press <Set>.
4. Perform scanning according to information displayed on the help information area.
You can zoom in a single window in the help information area to see the window more clearly. For details, please refer to “C.4.3 Single/quad-window Display”.
5. Press the user-defined key for entering iScanHelper again to exit.

C.3 Use iScanHelper for Learning or Training

1. Switch to the exam modes that support iScanHelper.
2. Press the user-defined key for entering iScanHelper to enter iScanHelper status.
3. Learn and practise views by system defaulted sequence according to the information displayed on help information area; or select unfamiliar views to practise.
You can zoom in a single window in the help information area to see the information. For details, please refer to “C.4.3 Single/quad-window Display”.
4. Press the user-defined key for entering iScanHelper again to exit iScanHelper.

C.4 Basic Screen and Operation



C.4.1 View Selecting Area

Rotate the trackball to move the cursor onto the target view and press <Set>, related information will be displayed on the help information area.

C.4.2 Help Information Area

Help information area displays on the lower right corner of the screen, providing ultrasonic image, anatomic graphic, scanning picture and scanning tips.



- Ultrasonic image
It is used to compare with images scanned by the operator.
- Anatomic graphic
Related anatomical tissue information are provided here.
- Scanning picture
Ordinary scanning tips can be observed here, including posture, probe mark, probe swing/sweep techniques.
- Scanning tips
You can read tissue related anatomical information and adjacent tissue information here.

C.4.3 Single/quad-window Display

You can zoom in the anatomic graphic, ultrasonic image as well as scanning picture to view those information more conveniently.

Press <Cursor> to obtain the cursor. Move the cursor on the anatomic graphic, the ultrasonic image or scanning tips. Double-click <Set> to go to the single window of each of them. Double-click single window again to return to quad-window display.

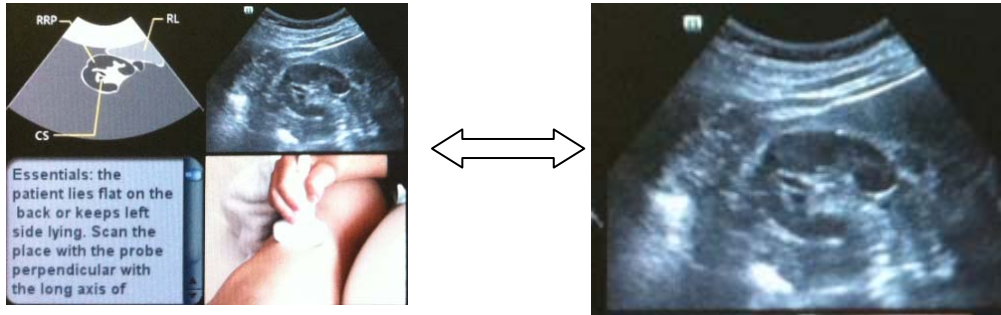

C.5 Measurement, Comments, and Body Mark

Switching probe or exam, measurement, comments and the body mark are unavailable under iScanHelper statu

Appendix D Wireless LAN

The system provides wireless net adapter configuration, so as to assist information query and unlimited network service.



WARNING

It is prohibited to use the wireless LAN function in an airplane, as this may violate the relevant provisions in the aviation regulations.

Use the wireless LAN function prudently in emergency ambulances (or other vehicles) as other devices or communication signals may be interfered with.

Use the wireless LAN function prudently in OR/ICU/CCU as it may interfere with other devices.

When the wireless LAN function is turned on, the ultrasound system may suffer interference from other equipment, even if that other equipment complies with CISPR EMISSION requirements.

Keep at least 20 cm away from the ultrasound system when the wireless LAN function is in use.

NOTE: For a better wireless LAN transmission effect, please take the following settings:

- SSID>80% with stable WLAN network;
- Wireless router and the server are in the same network segment;
- Router setting:
 - Wireless standard 802.11n
 - Maximum transmission speed $\geq 300M$
 - Use AP (access point) setting;
 - Number of the devices connected to the same router ≤ 5 .
- Target server setting:
 - Network is stable and not under overloading state (e.g. high CPU/memory usage, fast HDD speed, limited HDD space);
 - Level other than the highest level of firewall is adopted;
 - Operating system is Win8 or higher versions and it supports a Gigabit Ethernet.

Disconnection may be caused if the devices connected exceed the router capacity (please refer to settings of the router, generally it should be ≤ 5 .)

DO NOT connect devices other than specified into the LAN.

Medical devices within the same LAN may interfere with each other, the operator should be cautious. (Do not connect devices that may cause strong interference. For example, life-supporting devices should not be connected in the same LAN.)

Other non-medical devices in the same frequency band may cause interference, please be cautious.

Wi-Fi function is not affected when the system is imposed with radiation interference complied with IEC60601-1-2:2007 standard. See 12.5 Network Preset for the operation of WiFi in detail.

Appendix E Ultrasound Gel Warmer

Ultrasound gel warmer is a system option used for heating the ultrasound gel.

E.1 Overview

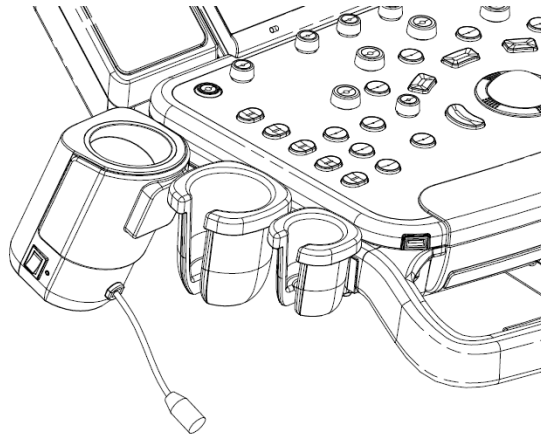

As shown in the figure above, the warmer is installed on the left side of the control panel, where the ultrasound gel is positioned.

E.2 Structure

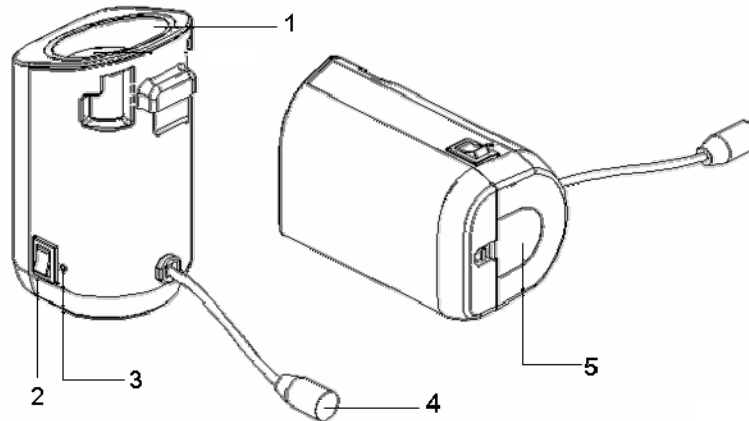

No.	Name	Function
1.	Ultrasound gel box	Used for positioning the ultrasound gel.
2.	Warming control switch	Set the gel warmer to the temperature of 37°C/40°C, or turn off.
3.	Status indicator	Working normally: green. Failure: blink in orange.
4.	Power cable	Connects to the power socket under the control panel.

No.	Name	Function
5.	Bottom cover	/

E.3 Specifications

■ Power supply

Voltage	12 V ⁻⁻⁻⁻
Power consumption	12 W

■ Environmental conditions

	Operating conditions	Storage and transportation conditions
Ambient temperature	0°C~40°C	-20°C~55°C
Relative humidity	30%~85% (no condensation)	20%~95% (no condensation)
Atmospheric pressure	700hPa~1060hPa	700hPa~1060hPa

E.4 Function and Requirement

The ultrasound gel warmer can heat the ultrasound gel to about 40±1°C at the most.

When the gel is placed inside the warmer, the time it takes to heat from an ambient temperature of 18°C to 28°C should be no more than 0.5 hours.

The ultrasound gel warmer can work continuously over 12 hours.

NOTE:	1.	When the ambient temperature is higher than the required temperature of the warmer, the warmer does not function.
	2.	The warmer can only heat one bottle of gel at a time.

E.5 Install the Warmer

1. As shown in the figure below, install the gel warmer into the gel holder on the control panel.

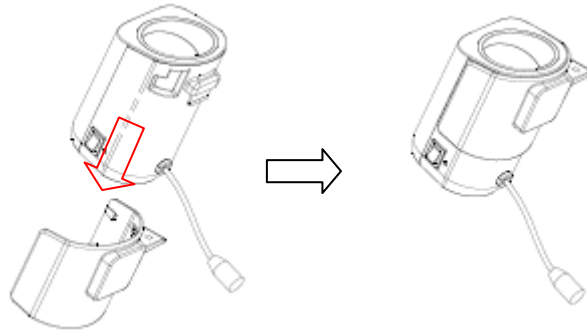

2. Align the buckle of the holder to the slot at the side of the control panel and then insert the buckle into the slot, push the warmer in the direction of the arrow until the buckle clicks and locks. Connect the power cable to the power socket under the control panel.

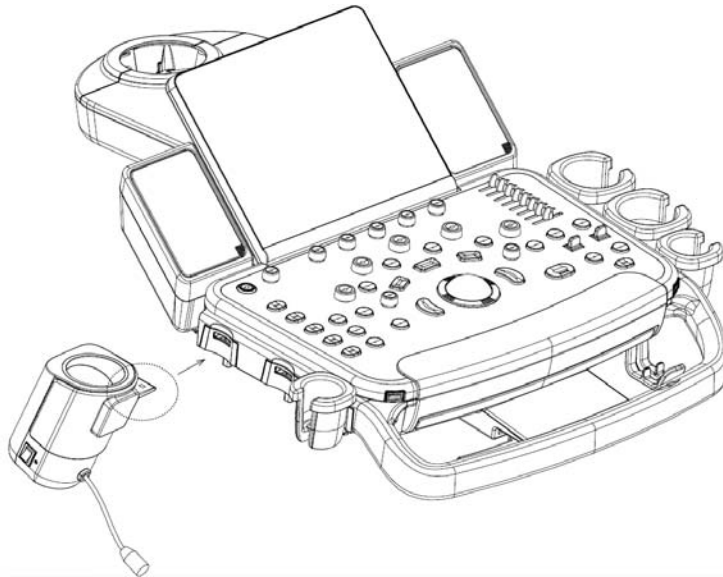

3. Insert the warmer's power plug into the jack on the back of the control panel.
4. Put the gel inside the warmer, and press the warming control switch, the gel warmer starts to work. There are three levels on the switch:
 - II: sets the warmer to 40°C
 - I: Sets the warmer to 37°C.
 - O: turn the warmer off.

NOTE: If the status indicator is off or blinks in orange after connecting the power cord, it means the gel warmer is not working normally, please turn it off and contract the service engineer.

E.6 Remove the Warmer

1. Pull out the power cable from the control panel jack.
2. As shown in the above figure, press the clip in the direction of the arrow to remove the warmer.

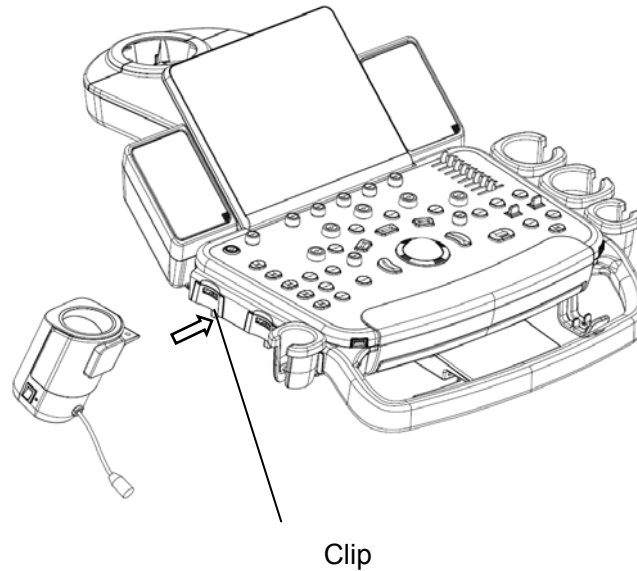

E.7 Cleaning

1. Press the clasp on the bottom cover to release the cover.

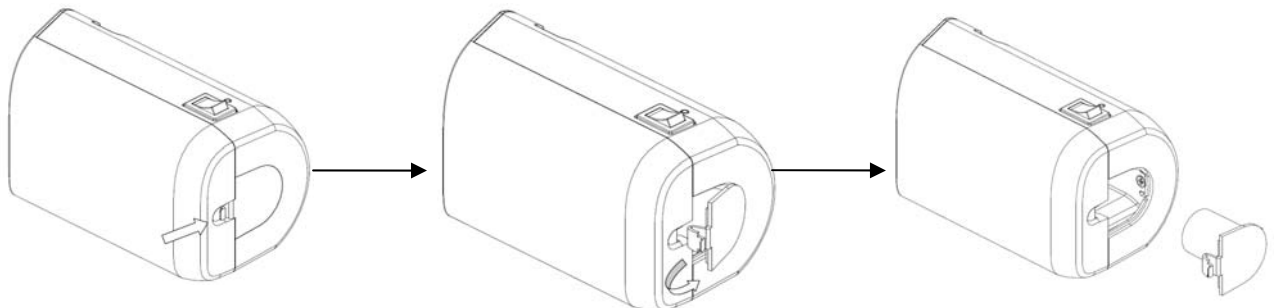

2. Remove and clean the cover.

Appendix F Batteries

-  **WARNING:**
1. The battery is inside the machine; only technical professionals from Mindray or engineers authorized by Mindray after training can perform battery installation and uninstallation.
 2. If you need to change the battery or buy a new one, please contact your sales representative.

F.1 Overview

The battery charges when the system is connected to the AC power supply.

- Generally, a completely discharged battery will fully charge in less than 6 hours.
- When the battery capacity is charged to the full capacity, it can support a standby period of no less than 24 hours.

- Note:**
1. Charge the battery in time when the battery capacity is empty when necessary; otherwise, the performance of the batteries is degraded.
 2. Power off the system if you will not use the system for a long period of time (including storage/ transportation condition), and you should not allow the system in standby status, otherwise the batteries will be out of power and permanently damaged.



When the external power supply is not connected, two lithium-ion batteries will provide the power.

Fully charged battery can ensure a normal working condition of more than 30 minutes (connecting to convex probe when powered on by default without peripherals).

-  **CAUTION:** Only move the machine in the power off or standby status or damage may happen.

F.2 Battery Status Indicator

The battery status indicator is located in the lower right corner of the screen, indicating the battery capacity.

- : Indicates the battery capacity is empty.
- : Indicates the battery capacity is full.
- The battery icons other than the two icons above-mentioned indicate the capacity is between empty and full.

When the power capacity is not enough, the system will pop up a prompt:

“Warning! Battery is out of power! Please connect to AC power or system will be shut down in one minute.” Connect to AC power to afford normal work.

F.3 One Full Discharge /Charge Cycle

Upon receipt of the system and before first time usage, it is recommended that you perform one full discharge /charge cycle. If the battery has not been used for over 2 months, you are recommended to perform one full discharge /charge cycle. It is also recommended that the battery is stored in the shady and cool area with FCC (full current capacity).

One Full Discharge / Charge Cycle:

1. Full discharge of the battery to let the system automatically shut down.
2. Charge the system to 100% FCC (full current capacity).
3. Discharge of the system for complete shutdown.

F.4 Checking Battery Performance

The battery performance may be degraded over time, so you need to check the battery performance periodically. The checking procedures are shown as follows:

1. Stop the ultrasound exam.
2. Connect the system to the AC power supply to charge the batteries until current capacity is full.
3. Disconnect the system from the AC power supply to power the system by the batteries until the system automatically shuts down.
4. The powering time of the batteries indicates the battery performance.

If the powering time of the battery is much shorter than that specified, you may replace the battery or contact the service personnel.

NOTE: The usage life of the battery is 300 charge / discharge cycles. If the battery is improperly used, its life may be shortened.

F.5 Battery Disposal

You need to dispose of the battery when it is damaged or severely degraded.

NOTE: You should observe the local regulations when disposing of the battery.

